



Lumec RoadFocus Plus smart solar powered system is an off-grid smart system featuring a unique and patented design luminaire, post-top PV panel, batteries and charge controller. The solution offers multiple lumen packages with industry leading efficacy, a complete array of optical distributions, ensuring the right fit for any type of roadway application. The solar subsystem comes with a pre-tilted bracket for optimum energy collection based on the location, system configuration, and wind speed. The system can be tailored to the expected night activities, number of cloudy days and solar irradiance available at the location.

Project: \_\_\_\_\_  
 Location: \_\_\_\_\_  
 Cat.No: \_\_\_\_\_  
 Type: \_\_\_\_\_  
 Lumens: \_\_\_\_\_ Qty: \_\_\_\_\_  
 Notes: \_\_\_\_\_

### Part I: ordering guide Luminaire<sup>1,2,3</sup>

example: RPS-SOL-80L-730-G1-R3M-HSS-MR-PDX02-BK

Series	Lumens	CRI/CCT	Generation	Distribution	Options	Operating Profiles <sup>7</sup>	Finish
<b>RPS-SOL</b>			<b>G1</b>				
RPS-SOL RoadFocus Plus small solar system	50L 5000 lm 60L 6000 lm 70L 7000 lm 80L 8000 lm 90L 9000 lm 100L 10000 lm 110L 11000 lm 120L 12000 lm	740 70CRI / 4000K 730 70CRI / 3000K 727 <sup>4</sup> 70CRI / 2700K	G1 Generation 1	<b>Type 2</b> R2M Type II Medium R2MB Type II Medium enhanced back-light R2S Type II Short <b>Type 3</b> R3M Type III Medium R3MB Type III Medium enhanced back-light R3S Type III Short <b>Type 4</b> 4 Type IV <b>Type 5</b> 5 Type V	MR Motion Response 2C Two clamps with 4 bolts <b>Shields<sup>5,6</sup></b> CSS Cul-de-Sac Shield HSS House Side Shield FSS Front Side Shield LSS Left Side Shield RSS Right Side Shield	<b>Luminaire without Motion Response (FD - Fixed Dimming)</b> FDD01 Fixed dimming #1 FDD02 Fixed dimming #2 FD530 100% for 5 hrs, then 30% till sunrise FD550 100% for 5 hrs, then 30% till sunrise <b>Luminaire with Motion Response (MR)<sup>8</sup> (PD - Profile Dimming)</b> PDD01 Profile dimming #1 PDD02 Profile dimming #2 PD30 100% with motion override and 30% without PD50 100% with motion override and 50% without	BK Black BR Bronze GY3 Gray WH White

### Part II: ordering guide Bracket example: RLARS-1A-R5@6-BK

Bracket series	Configuration	Pole Interface	Finish
<b>RLARS</b>	<b>1A</b>	<b>R5@6</b>	
RLARS RoadFocus Plus small solar system	1A 1 arm Side Mounted	R5@6	BK Black BR Bronze GY3 Gray WH White

### Part III: ordering guide Pole & Solar Sub-assembly<sup>9</sup>

example: SPR5V-20-P200-30-CB2-VDS-BK

Pole series	Pole Height <sup>10</sup>	Solar Panel Power	Solar Panel Tilt Angle	Battery Type/Capacity	Vibration Dampener <sup>11</sup>	Finish
ATR85N 0.188"	18 18 feet 23 23 feet	P200 200Wp	10 10° tilt	CB1 Crystal Battery 960Wh	VDS Vibration Dampening Solar	BK Black
SPR5J 0.180"	19 19 feet 24 24 feet	P325 325Wp	20 20° tilt	CB2 Crystal Battery 1,680Wh		BR Bronze
SPR5V 0.250"	20 20 feet 25 25 feet		30 30° tilt	CB3 Crystal Battery 2,400Wh		GY3 Gray
SSM8V 0.250"	21 21 feet 26 26 feet		40 40° tilt			WH White
	22 22 feet 27 27 feet		50 50° tilt			

### Default anchor bolts & circles for solar poles (optional)

Anchor bolt ordering code	Pole Family	Bolt circle diameter
1x36-11-DEC	ATR85N	11
1x36-12 1/2-DEC	SPR5J	12 1/2
1x36-12 1/2-DEC	SPR5V	12 1/2
1x36-12 1/2-DEC	SPR8V	12 1/2

example: 1x36-12 1/2-DEC

- Please use our online [Outdoor 3D configurator](#) for a faster parts selection (recommended).
- All system parts I, II and III must be ordered together and cannot be ordered separately
- Ground rod must be provided and installed by contractor as per National Electrical code (NEC) article 250.52 (A)(5) or the local application regulation agency.
- Extended lead-time may apply (consult factory).
- Refer to Accessories section to confirm compatibility of shields with optical distribution.
- One shield provided per LED light engine.

- Operating profiles can be changed at the site via a mobile device using a dedicated app, operating profiles details are in pages 5 & 6. Pre-programmed custom operating profiles are available upon request.
- Profile Dimming (PD) is only available for luminaires equipped with Motion Response (MR).
- Pole selection is based on height, wind speed, solar system size and tilting angle. Please check page 7 and 8 for poles selection table.
- Luminaire mounting height is 2 ft below the pole height.
- VDS (Vibration Dampening Solar) is only supplied with steel poles (SPR5J, SPR5V and SSM8V).

# RPS-SOL RoadFocus Plus

Smart solar powered system



# RPS-SOL RoadFocus Plus

## Smart solar powered system

**Accessories** Must be ordered as separate line items - quickly and easily installed in the field

Description	Ordering Code	Shield vs Distribution Compatibility									
	10 LED version	R2M	R2MB	R2MHE	R2S	R3M	R3MB	R3MHE	R3S	4	5
Cul-de-sac shield	ACC-LG66V40LED-CSS	Yes	Yes	Yes	Yes	Yes	Yes	No	Yes	No	No
Front side shield	ACC-LG66V40LED-FSS	Yes	Yes	Yes	Yes	Yes	Yes	No	Yes	No	No
Front side shield (for Type 4 only)	ACC-LG66V40LED-FSS-4	No	No	No	No	No	No	Yes	No	Yes	No
House side shield	ACC-LG66V40LED-HSS	Yes	Yes	Yes	Yes	Yes	Yes	No	Yes	No	No
House side shield (for Type 4 only)	ACC-LG66V40LED-HSS-4	No	No	No	No	No	No	Yes	No	Yes	No
Left side shield	ACC-LG66V40LED-LSS	Yes	Yes	Yes	Yes	Yes	Yes	No	Yes	No	No
Right side shield	ACC-LG66V40LED-RSS	Yes	Yes	Yes	Yes	Yes	Yes	No	Yes	No	No

### Predicted Lumen Depreciation Data

Derived from LED manufacturer's data and engineering design estimates, based on IESNA LM-80 methodology. Actual experience may vary due to field application conditions. L70 is the predicted time when LED performance depreciates to 70% of initial lumen output. Calculated per IESNA TM21-21.

Ambient Temperature	L70 per TM-21	Lumen Maintenance % at 77,000 hrs
25°C	>100,000 hrs	See table below

### Standard Performance Wattage Values

Ordering Code	Total LEDs	Light Engine Config.	Avg. System Watts (W) <sup>1</sup>	Lumen maintenance at			
				25K hrs	50K hrs	75K hrs	100K hrs
RPS-SOL-50L	40	1x40LED	25.6	99%	97%	95%	93%
RPS-SOL-60L	40	1x40LED	27.2	99%	97%	95%	93%
RPS-SOL-70L	40	1x40LED	37.4	99%	97%	95%	93%
RPS-SOL-80L	40	1x40LED	43.3	99%	97%	95%	93%
RPS-SOL-90L	40	1x40LED	49.5	99%	97%	95%	93%
RPS-SOL-100L	40	1x40LED	54.8	99%	97%	95%	93%
RPS-SOL-110L	40	1x40LED	62.3	99%	97%	95%	93%
RPS-SOL-120L	40	1x40LED	69	99%	97%	95%	93%

### 4000K/70CRI LED Lumen Values

Ordering Code	Type R2M			Type R2S			Type R3M			Type R3S		
	Lumen Output	Efficacy (LPW)	BUG Rating	Lumen Output	Efficacy (LPW)	BUG Rating	Lumen Output	Efficacy (LPW)	BUG Rating	Lumen Output	Efficacy (LPW)	BUG Rating
RPS-SOL-50L-740	4958	194	B1-U0-G1	5122	200	B2-U0-G1	4936	193	B1-U0-G1	4956	194	B1-U0-G1
RPS-SOL-60L-740	5886	216	B2-U0-G2	6081	223	B2-U0-G2	5860	215	B2-U0-G1	5883	216	B1-U0-G1
RPS-SOL-70L-740	7052	188	B2-U0-G2	7285	195	B2-U0-G2	7020	188	B2-U0-G1	7049	188	B2-U0-G2
RPS-SOL-80L-740	8043	186	B2-U0-G2	8309	192	B2-U0-G2	8007	185	B2-U0-G2	8039	186	B2-U0-G2
RPS-SOL-90L-740	9067	183	B2-U0-G2	9368	189	B2-U0-G2	9027	182	B2-U0-G2	9063	183	B2-U0-G2
RPS-SOL-100L-740	9919	181	B2-U0-G2	10248	187	B3-U0-G2	9874	180	B2-U0-G2	9914	181	B2-U0-G2
RPS-SOL-110L-740	10889	175	B3-U0-G3	11250	180	B3-U0-G3	10840	174	B2-U0-G2	10884	175	B2-U0-G2
RPS-SOL-120L-740	12006	174	B3-U0-G3	12404	180	B3-U0-G3	11952	173	B3-U0-G2	12001	174	B2-U0-G2

Ordering Code	Type 4			Type 5			Type R2MB			Type R3MB		
	Lumen Output	Efficacy (LPW)	BUG Rating	Lumen Output	Efficacy (LPW)	BUG Rating	Lumen Output	Efficacy (LPW)	BUG Rating	Lumen Output	Efficacy (LPW)	BUG Rating
RPS-SOL-50L-740	4908	192	B1-U0-G1	4981	195	B3-U0-G1	5139	201	B2-U0-G2	4991	195	B2-U0-G2
RPS-SOL-60L-740	5827	214	B1-U0-G2	5914	217	B3-U0-G2	6101	224	B2-U0-G2	5925	218	B2-U0-G2
RPS-SOL-70L-740	6981	186	B1-U0-G2	7084	189	B3-U0-G2	7309	195	B2-U0-G2	7098	190	B2-U0-G2
RPS-SOL-80L-740	7962	184	B1-U0-G2	8080	186	B3-U0-G2	8337	192	B2-U0-G2	8096	187	B2-U0-G2
RPS-SOL-90L-740	8976	181	B1-U0-G2	9109	184	B4-U0-G2	9399	190	B3-U0-G3	9127	184	B2-U0-G2
RPS-SOL-100L-740	9820	179	B2-U0-G2	9965	182	B4-U0-G2	10281	187	B3-U0-G3	9984	182	B3-U0-G3
RPS-SOL-110L-740	10780	173	B2-U0-G2	10940	175	B4-U0-G2	11287	181	B3-U0-G3	10961	176	B3-U0-G3
RPS-SOL-120L-740	11886	172	B2-U0-G2	12062	175	B4-U0-G2	12445	181	B3-U0-G3	12085	175	B3-U0-G3

Actual performance may vary due to installation variables including optics, mounting/ceiling height, dirt depreciation, light loss factor, etc.; highly recommended to confirm performance with a layout - contact Applications at [signify.com/outdoorluminaires](mailto:signify.com/outdoorluminaires).  
Note: Some data may be scaled based on tests of similar but not identical luminaires.

# RPS-SOL RoadFocus Plus

Smart solar powered system

## 3000K/70CRI LED Lumen Values

Ordering Code	Type R2M			Type R2S			Type R3M			Type R3S		
	Lumen Output	Efficacy (LPW)	BUG Rating	Lumen Output	Efficacy (LPW)	BUG Rating	Lumen Output	Efficacy (LPW)	BUG Rating	Lumen Output	Efficacy (LPW)	BUG Rating
RPS-SOL-50L-730	4735	185	B1-U0-G1	4892	191	B1-U0-G1	4714	184	B1-U0-G1	4733	185	B1-U0-G1
RPS-SOL-60L-730	5621	207	B2-U0-G2	5808	213	B2-U0-G2	5596	206	B1-U0-G1	5619	206	B1-U0-G1
RPS-SOL-70L-730	6734	180	B2-U0-G2	6958	186	B2-U0-G2	6704	179	B2-U0-G1	6731	180	B2-U0-G1
RPS-SOL-80L-730	7681	177	B2-U0-G2	7935	183	B2-U0-G2	7646	176	B2-U0-G2	7677	177	B2-U0-G2
RPS-SOL-90L-730	8659	175	B2-U0-G2	8946	181	B2-U0-G2	8620	174	B2-U0-G2	8655	175	B2-U0-G2
RPS-SOL-100L-730	9472	173	B2-U0-G2	9786	178	B2-U0-G2	9430	172	B2-U0-G2	9468	173	B2-U0-G2
RPS-SOL-110L-730	10399	167	B2-U0-G2	10744	172	B3-U0-G3	10353	166	B2-U0-G2	10395	167	B2-U0-G2
RPS-SOL-120L-730	11466	166	B3-U0-G3	11846	172	B3-U0-G3	11415	166	B2-U0-G2	11461	166	B2-U0-G2

Ordering Code	Type 4			Type 5			Type R2MB			Type R3MB		
	Lumen Output	Efficacy (LPW)	BUG Rating	Lumen Output	Efficacy (LPW)	BUG Rating	Lumen Output	Efficacy (LPW)	BUG Rating	Lumen Output	Efficacy (LPW)	BUG Rating
RPS-SOL-50L-730	4688	183	B1-U0-G1	4757	186	B3-U0-G1	4908	192	B2-U0-G2	4766	186	B2-U0-G2
RPS-SOL-60L-730	5565	204	B1-U0-G1	5647	207	B3-U0-G1	5827	214	B2-U0-G2	5658	208	B2-U0-G2
RPS-SOL-70L-730	6667	178	B1-U0-G2	6766	181	B3-U0-G2	6980	186	B2-U0-G2	6779	181	B2-U0-G2
RPS-SOL-80L-730	7604	175	B1-U0-G2	7717	178	B3-U0-G2	7962	184	B2-U0-G2	7731	178	B2-U0-G2
RPS-SOL-90L-730	8572	173	B1-U0-G2	8699	176	B3-U0-G2	8976	181	B3-U0-G3	8716	176	B2-U0-G2
RPS-SOL-100L-730	9378	171	B2-U0-G2	9517	174	B4-U0-G2	9819	179	B3-U0-G3	9535	174	B3-U0-G3
RPS-SOL-110L-730	10295	165	B2-U0-G2	10448	168	B4-U0-G2	10779	173	B3-U0-G3	10468	168	B3-U0-G3
RPS-SOL-120L-730	11351	165	B2-U0-G2	11519	167	B4-U0-G2	11885	172	B3-U0-G3	11541	167	B3-U0-G3

Actual performance may vary due to installation variables including optics, mounting/ceiling height, dirt depreciation, light loss factor, etc.;

highly recommended to confirm performance with a layout - contact Applications at [signify.com/outdoorluminaire](http://signify.com/outdoorluminaire).

Note: Some data may be scaled based on tests of similar but not identical luminaires.

## 2700K/70CRI LED Lumen Values

Ordering Code	Type R2M			Type R2S			Type R3M			Type R3S		
	Lumen Output	Efficacy (LPW)	BUG Rating	Lumen Output	Efficacy (LPW)	BUG Rating	Lumen Output	Efficacy (LPW)	BUG Rating	Lumen Output	Efficacy (LPW)	BUG Rating
RPS-SOL-50L-727	4294	168	B1-U0-G1	4436	173	B1-U0-G1	4274	167	B1-U0-G1	4292	168	B1-U0-G1
RPS-SOL-60L-727	5097	187	B1-U0-G1	5266	193	B2-U0-G1	5075	186	B1-U0-G1	5095	187	B1-U0-G1
RPS-SOL-70L-727	6107	163	B2-U0-G2	6309	169	B2-U0-G2	6079	162	B2-U0-G1	6104	163	B1-U0-G1
RPS-SOL-80L-727	6965	161	B2-U0-G2	7196	166	B2-U0-G2	6934	160	B2-U0-G1	6962	161	B2-U0-G2
RPS-SOL-90L-727	7852	159	B2-U0-G2	8112	164	B2-U0-G2	7817	158	B2-U0-G2	7849	159	B2-U0-G2
RPS-SOL-100L-727	8590	157	B2-U0-G2	8874	162	B2-U0-G2	8551	156	B2-U0-G2	8586	157	B2-U0-G2
RPS-SOL-110L-727	9430	151	B2-U0-G2	9743	156	B2-U0-G2	9388	151	B2-U0-G2	9426	151	B2-U0-G2
RPS-SOL-120L-727	10397	151	B2-U0-G2	10742	156	B3-U0-G3	10351	150	B2-U0-G2	10393	151	B2-U0-G2

Ordering Code	Type 4			Type 5			Type R2MB			Type R3MB		
	Lumen Output	Efficacy (LPW)	BUG Rating	Lumen Output	Efficacy (LPW)	BUG Rating	Lumen Output	Efficacy (LPW)	BUG Rating	Lumen Output	Efficacy (LPW)	BUG Rating
RPS-SOL-50L-727	4251	166	B1-U0-G1	4314	169	B3-U0-G1	4451	174	B1-U0-G1	4322	169	B1-U0-G1
RPS-SOL-60L-727	5046	185	B1-U0-G1	5121	188	B3-U0-G1	5284	194	B2-U0-G2	5131	189	B2-U0-G2
RPS-SOL-70L-727	6046	161	B1-U0-G2	6135	164	B3-U0-G2	6330	169	B2-U0-G2	6147	164	B2-U0-G2
RPS-SOL-80L-727	6895	159	B1-U0-G2	6997	161	B3-U0-G2	7220	167	B2-U0-G2	7011	162	B2-U0-G2
RPS-SOL-90L-727	7774	157	B1-U0-G2	7889	159	B3-U0-G2	8139	164	B2-U0-G2	7904	160	B2-U0-G2
RPS-SOL-100L-727	8504	155	B1-U0-G2	8630	157	B3-U0-G2	8904	162	B2-U0-G2	8646	158	B2-U0-G2
RPS-SOL-110L-727	9336	150	B1-U0-G2	9474	152	B4-U0-G2	9775	157	B3-U0-G3	9492	152	B2-U0-G2
RPS-SOL-120L-727	10293	149	B2-U0-G2	10446	152	B4-U0-G2	10777	156	B3-U0-G3	10466	152	B3-U0-G3

Actual performance may vary due to installation variables including optics, mounting/ceiling height, dirt depreciation, light loss factor, etc.;

highly recommended to confirm performance with a layout - contact Applications at [signify.com/outdoorluminaire](http://signify.com/outdoorluminaire). Consult DLC QPL to confirm your specific fixture selection is DLC approved.

Note: Some data may be scaled based on tests of similar but not identical luminaires.

# RPS-SOL RoadFocus Plus

## Smart solar powered system

### FD - Fixed Dimming (Without Motion Sensor)

#### FDD01

- First 5 hours from dusk light level fixed at 100%.
- Remaining hours to dawn minus 1-hour, light level fixed at 30% (dynamic duration based on night length)
- Last 1-hour before dawn, light level fixed at 100%.
- One hour before dawn, light level fixed at 100%

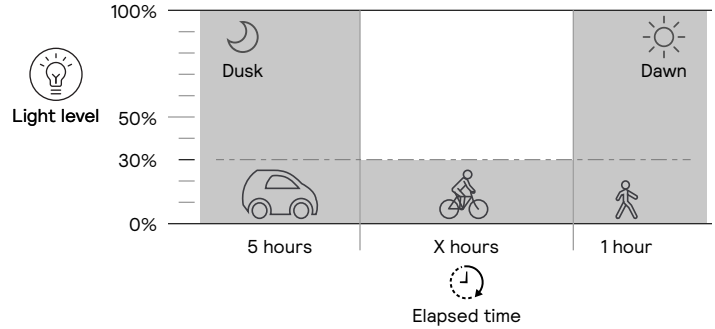

#### FDD02

- First 5 hours from dusk, light level fixed at 100%.
- Remaining hours to dawn minus 1-hour, light level fixed at 50% (dynamic duration based on the length).
- One hour before dawn, light level fixed at 100%.

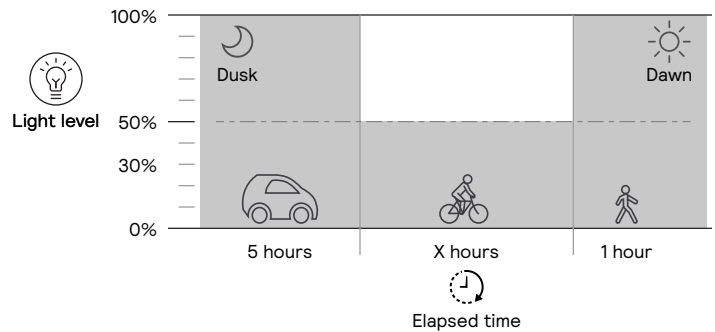

#### FD530

- First 5 hours from dusk light level fixed at 100%.
- Remaining hours to dawn, light level fixed at 30%.

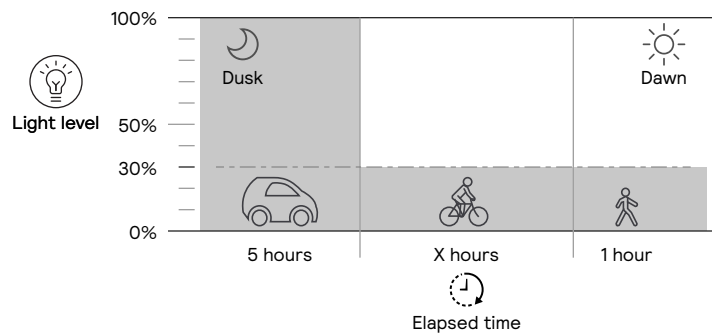

#### FD550

- First 5 hours from dusk light level fixed at 100%.
- Remaining hours to dawn, light level fixed at 50%.

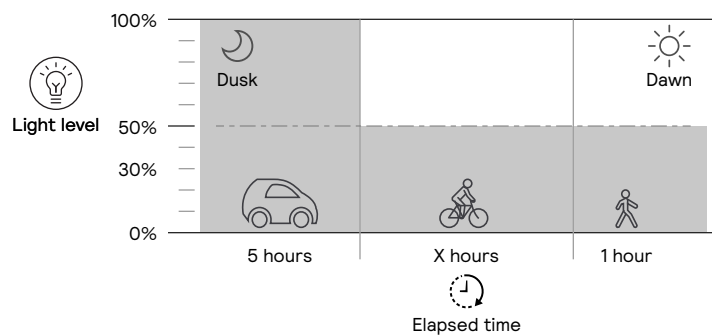

# RPS-SOL RoadFocus Plus

## Smart solar powered system

### PD - Profile Dimming

#### PDD01

- First 5 hours from dusk light level 100% when motion is detected and 30% when no motion is detected.
- Remaining hours to dawn **minus 1-hour**, motion sensor disabled, and light level fixed at 30% (dynamic duration based on night length).
- One hour before dawn, light level at 100% when motion is detected and 30% without motion.

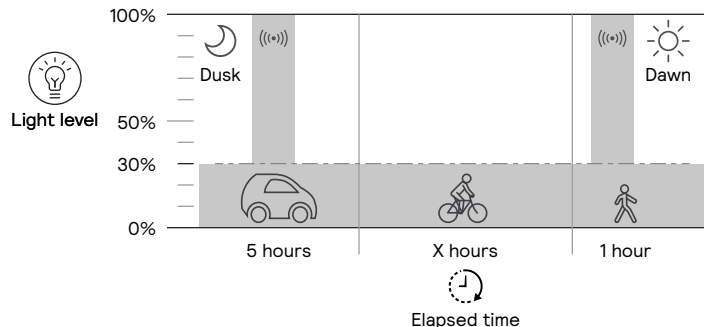

#### PDD02

- First 5 hours from dusk, light level 100% when motion is detected and 50% when no motion is detected.
- Remaining hours to dawn minus 1-hour, motion sensor disabled, and light level fixed at 50% (dynamic duration based on night length).
- One hour before dawn, light level at 100% when motion is detected and 50% without motion.

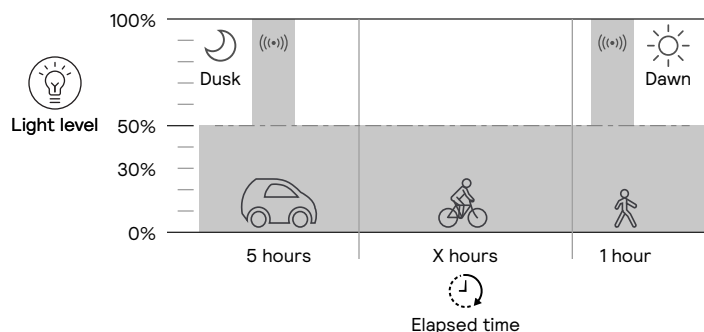

#### PD30

- Dusk to dawn, light level is at 100% with motion and at 30% without motion.

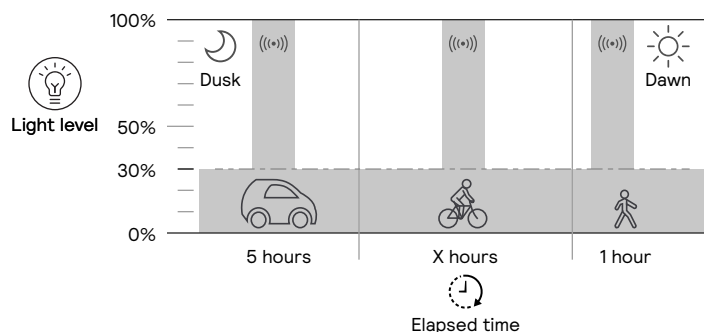

#### PD50

- Dusk to dawn, light level is at 100% with motion and at 50% without motion.

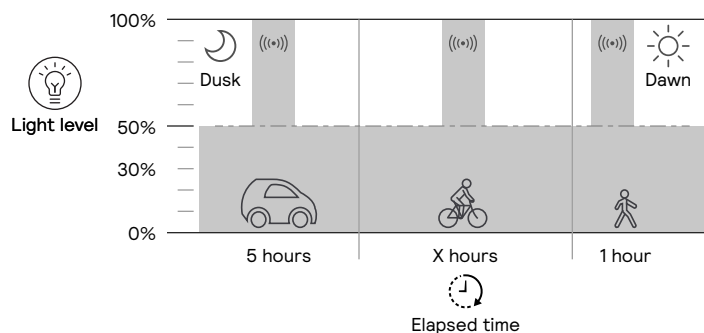

# RPS-SOL RoadFocus Plus

Smart solar powered system

**AASHTO Compliant Poles Selection Tables** Luminaire Mounting Height is 2 ft Less Than the Total Pole Height

PV Panels with 10° tilt		(H) Total Pole Height (ft) – Aluminum & Steel Poles									
		18		19-20		21-22		23-24		25-27	
		200w	325w	200w	325w	200w	325w	200w	325w	200w	325w
Wind Speed (MPH)	150	SPR5J	SPR5J	SPR5J	SPR5J	SPR5J	SPR5J	SPR5J	SPR5J	SPR5J	SPR5J
	140	ATR85N	SPR5J	SPR5J	SPR5J	SPR5J	SPR5J	SPR5J	SPR5J	SPR5J	SPR5J
	130	ATR85N	ATR85N	ATR85N	SPR5J	SPR5J	SPR5J	SPR5J	SPR5J	SPR5J	SPR5J
	120	ATR85N	ATR85N	ATR85N	ATR85N	ATR85N	SPR5J	SPR5J	SPR5J	SPR5J	SPR5J
	110	ATR85N	ATR85N	ATR85N	ATR85N	ATR85N	ATR85N	ATR85N	ATR85N	SPR5J	SPR5J
	100	ATR85N	ATR85N	ATR85N	ATR85N	ATR85N	ATR85N	ATR85N	ATR85N	ATR85N	SPR5J
	90	ATR85N	ATR85N	ATR85N	ATR85N	ATR85N	ATR85N	ATR85N	ATR85N	ATR85N	ATR85N
	80	ATR85N	ATR85N	ATR85N	ATR85N	ATR85N	ATR85N	ATR85N	ATR85N	ATR85N	ATR85N
	70	ATR85N	ATR85N	ATR85N	ATR85N	ATR85N	ATR85N	ATR85N	ATR85N	ATR85N	ATR85N

PV Panels with 20° tilt		(H) Total Pole Height (ft) – Aluminum & Steel Poles									
		18		19-20		21-22		23-24		25-27	
		200w	325w	200w	325w	200w	325w	200w	325w	200w	325w
Wind Speed (MPH)	150	SPR5J	SPR5V	SPR5J	SPR5V	SPR5J	SSM8V	SPR5V	SSM8V	SSM8V	SSM8V
	140	SPR5J	SPR5J	SPR5J	SPR5V	SPR5J	SPR5V	SPR5V	SSM8V	SPR5V	SSM8V
	130	ATR85N	SPR5J	SPR5J	SPR5J	SPR5J	SPR5V	SPR5J	SPR5V	SPR5V	SSM8V
	120	ATR85N	ATR85N	ATR85N	SPR5J	SPR5J	SPR5J	SPR5J	SPR5V	SPR5J	SPR5V
	110	ATR85N	ATR85N	ATR85N	ATR85N	ATR85N	SPR5J	SPR5J	SPR5J	SPR5J	SPR5V
	100	ATR85N	ATR85N	ATR85N	ATR85N	ATR85N	ATR85N	ATR85N	SPR5J	SPR5J	SPR5J
	90	ATR85N	ATR85N	ATR85N	ATR85N	ATR85N	ATR85N	ATR85N	ATR85N	ATR85N	SPR5J
	80	ATR85N	ATR85N	ATR85N	ATR85N	ATR85N	ATR85N	ATR85N	ATR85N	ATR85N	ATR85N
	70	ATR85N	ATR85N	ATR85N	ATR85N	ATR85N	ATR85N	ATR85N	ATR85N	ATR85N	ATR85N

PV Panels with 30° tilt		(H) Total Pole Height (ft) – Aluminum & Steel Poles									
		18		19-20		21-22		23-24		25-27	
		200w	325w	200w	325w	200w	325w	200w	325w	200w	325w
Wind Speed (MPH)	150	SPR5J	SPR5V	SPR5V	SSM8V	SSM8V	SSM8V	SSM8V	SSM8V	SSM8V	-
	140	SPR5J	SPR5J	SPR5V	SSM8V	SPR5V	SSM8V	SSM8V	SSM8V	SSM8V	SSM8V
	130	SPR5J	SPR5J	SPR5J	SPR5V	SPR5V	SSM8V	SPR5V	SSM8V	SPR5V	SSM8V
	120	ATR85N	SPR5J	SPR5J	SPR5J	SPR5J	SPR5V	SPR5V	SPR5V	SPR5V	SSM8V
	110	ATR85N	SPR5J	ATR85N	SPR5J	SPR5J	SPR5J	SPR5J	SPR5V	SPR5V	SSM8V
	100	ATR85N	ATR85N	ATR85N	SPR5J	ATR85N	SPR5J	SPR5J	SPR5J	SPR5J	SPR5V
	90	ATR85N	ATR85N	ATR85N	ATR85N	ATR85N	ATR85N	ATR85N	SPR5J	SPR5J	SPR5J
	80	ATR85N	ATR85N	ATR85N	ATR85N	ATR85N	ATR85N	ATR85N	ATR85N	ATR85N	SPR5J
	70	ATR85N	ATR85N	ATR85N	ATR85N	ATR85N	ATR85N	ATR85N	ATR85N	ATR85N	ATR85N

PV Panels with 40° tilt		(H) Total Pole Height (ft) – Aluminum & Steel Poles									
		18		19-20		21-22		23-24		25-27	
		200w	325w	200w	325w	200w	325w	200w	325w	200w	325w
Wind Speed (MPH)	150	SPR5V	SSM8V	SSM8V	SSM8V	SSM8V	-	SSM8V	-	-	-
	140	SPR5V	SSM8V	SPR5V	SSM8V	SSM8V	SSM8V	SSM8V	-	-	-
	130	SPR5J	SSM8V	SPR5V	SSM8V	SPR5V	SSM8V	SSM8V	SSM8V	SSM8V	-
	120	SPR5J	SPR5V	SPR5J	SSM8V	SPR5V	SSM8V	SPR5V	SSM8V	SSM8V	-
	110	SPR5J	SPR5J	SPR5J	SPR5V	SPR5J	SSM8V	SPR5V	SSM8V	SPR5V	SSM8V
	100	ATR85N	SPR5J	SPR5J	SPR5J	SPR5J	SPR5V	SPR5J	SPR5V	SPR5V	SSM8V
	90	ATR85N	ATR85N	ATR85N	SPR5J	ATR85N	SPR5J	SPR5J	SPR5V	SPR5J	SPR5V
	80	ATR85N	ATR85N	ATR85N	ATR85N	ATR85N	SPR5J	ATR85N	SPR5J	SPR5J	SPR5J
	70	ATR85N	ATR85N	ATR85N	ATR85N	ATR85N	ATR85N	ATR85N	ATR85N	ATR85N	SPR5J

PV Panels with 50° tilt		(H) Total Pole Height (ft) – Aluminum & Steel Poles									
		18		19-20		21-22		23-24		25-27	
		200w	325w	200w	325w	200w	325w	200w	325w	200w	325w
Wind Speed (MPH)	150	SSM8V	-	SSM8V	-	SSM8V	-	-	-	-	-
	140	SPR5V	SSM8V	SSM8V	-	SSM8V	-	SSM8V	-	-	-
	130	SPR5V	SSM8V	SPR5V	SSM8V	SSM8V	-	SSM8V	-	-	-
	120	SPR5J	SSM8V	SPR5V	SSM8V	SPR5V	SSM8V	SSM8V	SSM8V	SSM8V	-
	110	SPR5J	SPR5V	SPR5J	SSM8V	SPR5V	SSM8V	SPR5V	SSM8V	SSM8V	-
	100	SPR5J	SPR5J	SPR5J	SPR5V	SPR5J	SPR5V	SPR5V	SSM8V	SPR5V	SSM8V
	90	ATR85N	SPR5J	ATR85N	SPR5J	SPR5J	SPR5V	SPR5J	SPR5V	SPR5V	SSM8V
	80	ATR85N	ATR85N	ATR85N	SPR5J	ATR85N	SPR5J	ATR85N	SPR5J	SPR5J	SPR5V
	70	ATR85N	ATR85N	ATR85N	ATR85N	ATR85N	ATR85N	ATR85N	SPR5J	ATR85N	SPR5J

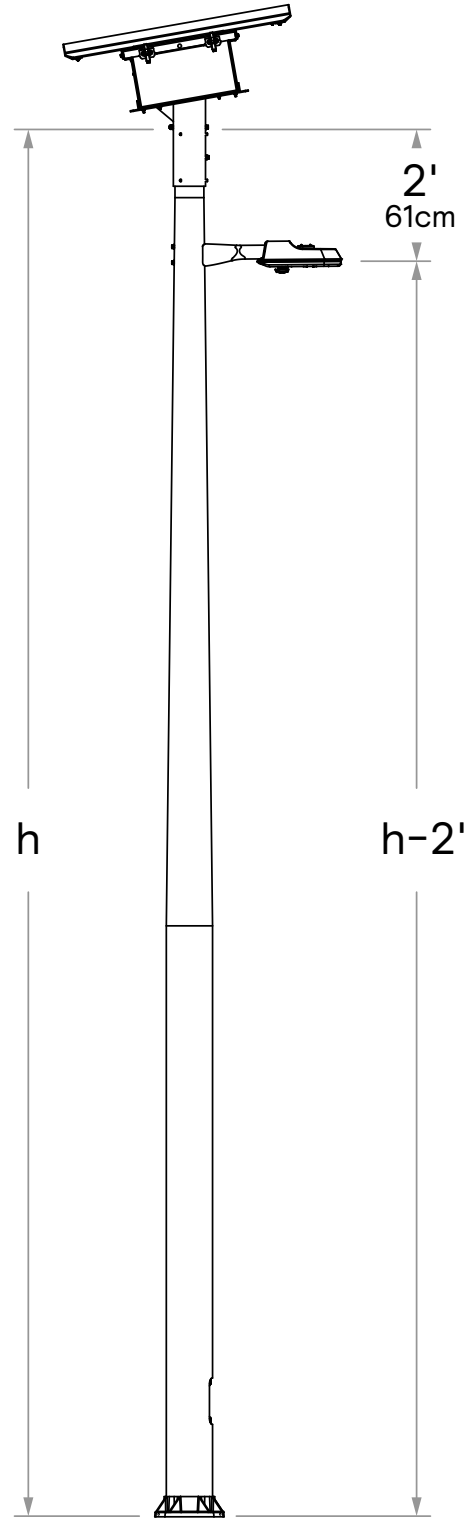

# RPS-SOL RoadFocus Plus

Smart solar powered system

CSA Compliant Poles Selection Tables Luminaire Mounting Height is 2 ft Less Than the Total Pole Height

PV Panels with 10° tilt		(h) Total Pole Height (ft) – Aluminum & Steel Poles									
		18		19-20		21-22		23-24		25-27	
		200w	325w	200w	325w	200w	325w	200w	325w	200w	325w
Wind Speed (MPH)	150	SPR5J	SPR5V	SPR5V	SSM8V	SPR5V	SSM8V	SSM8V	SSM8V	SSM8V	SSM8V
	140	SPR5J	SPR5J	SPR5J	SPR5V	SPR5V	SSM8V	SSM8V	SSM8V	SSM8V	SSM8V
	130	SPR5J	SPR5J	SPR5J	SPR5V	SPR5V	SSM8V	SSM8V	SSM8V	SSM8V	SSM8V
	120	SPR5J	SPR5J	SPR5J	SPR5J	SPR5J	SPR5V	SPR5V	SSM8V	SSM8V	SSM8V
	110	ATR85N	SPR5J	SPR5J	SPR5J	SPR5J	SPR5J	SPR5V	SPR5V	SSM8V	SSM8V
	100	ATR85N	ATR85N	ATR85N	SPR5J	SPR5J	SPR5J	SPR5J	SPR5J	SPR5J	SPR5V
	90	ATR85N	ATR85N	ATR85N	ATR85N	ATR85N	SPR5J	SPR5J	SPR5J	SPR5J	SPR5J
	80	ATR85N	ATR85N	ATR85N	ATR85N	ATR85N	ATR85N	ATR85N	ATR85N	SPR5J	SPR5J
	70	ATR85N	ATR85N	ATR85N	ATR85N	ATR85N	ATR85N	ATR85N	ATR85N	ATR85N	ATR85N

PV Panels with 20° tilt		(h) Total Pole Height (ft) – Aluminum & Steel Poles									
		18		19-20		21-22		23-24		25-27	
		200w	325w	200w	325w	200w	325w	200w	325w	200w	325w
Wind Speed (MPH)	150	SPR5V	SSM8V	SPR5V	SSM8V	SSM8V	SSM8V	SSM8V	-	-	-
	140	SPR5J	SPR5V	SPR5V	SSM8V	SSM8V	SSM8V	SSM8V	SSM8V	SSM8V	-
	130	SPR5J	SPR5V	SPR5V	SSM8V	SPR5V	SSM8V	SSM8V	SSM8V	SSM8V	SSM8V
	120	SPR5J	SPR5J	SPR5J	SPR5V	SPR5V	SSM8V	SPR5V	SSM8V	SSM8V	SSM8V
	110	SPR5J	SPR5J	SPR5J	SPR5V	SPR5V	SSM8V	SPR5V	SSM8V	SSM8V	SSM8V
	100	ATR85N	SPR5J	SPR5J	SPR5J	SPR5J	SPR5J	SPR5J	SPR5V	SPR5V	SSM8V
	90	ATR85N	ATR85N	ATR85N	SPR5J	SPR5J	SPR5J	SPR5J	SPR5J	SPR5J	SPR5V
	80	ATR85N	ATR85N	ATR85N	ATR85N	ATR85N	SPR5J	ATR85N	SPR5J	SPR5J	SPR5J
	70	ATR85N	ATR85N	ATR85N	ATR85N	ATR85N	ATR85N	ATR85N	ATR85N	ATR85N	SPR5J

PV Panels with 30° tilt		(h) Total Pole Height (ft) – Aluminum & Steel Poles									
		18		19-20		21-22		23-24		25-27	
		200w	325w	200w	325w	200w	325w	200w	325w	200w	325w
Wind Speed (MPH)	150	SPR5V	SSM8V	SSM8V	SSM8V	SSM8V	-	-	-	-	-
	140	SPR5V	SSM8V	SSM8V	SSM8V	SSM8V	SSM8V	SSM8V	SSM8V	SSM8V	-
	130	SPR5V	SSM8V	SSM8V	SPR5V	SSM8V	SSM8V	SSM8V	SSM8V	SSM8V	-
	120	SPR5J	SPR5V	SPR5V	SSM8V	SPR5V	SSM8V	SSM8V	SSM8V	SSM8V	SSM8V
	110	SPR5J	SPR5V	SPR5J	SPR5V	SPR5V	SSM8V	SPR5V	SSM8V	SSM8V	SSM8V
	100	SPR5J	SPR5J	SPR5J	SPR5V	SPR5J	SPR5V	SPR5V	SSM8V	SSM8V	SSM8V
	90	ATR85N	SPR5J	SPR5J	SPR5J	SPR5J	SPR5J	SPR5J	SPR5V	SPR5V	SSM8V
	80	ATR85N	ATR85N	ATR85N	SPR5J	ATR85N	SPR5J	SPR5J	SPR5J	SPR5J	SPR5V
	70	ATR85N	ATR85N	ATR85N	ATR85N	ATR85N	ATR85N	SPR5J	SPR5J	SPR5J	SPR5V

PV Panels with 40° tilt		(h) Total Pole Height (ft) – Aluminum & Steel Poles									
		18		19-20		21-22		23-24		25-27	
		200w	325w	200w	325w	200w	325w	200w	325w	200w	325w
Wind Speed (MPH)	150	SSM8V	SSM8V	SSM8V	-	SSM8V	-	-	-	-	-
	140	SSM8V	SSM8V	SSM8V	SSM8V	SSM8V	-	SSM8V	-	-	-
	130	SSM8V	SSM8V	SSM8V	SSM8V	SSM8V	-	SSM8V	-	-	-
	120	SPR5V	SSM8V	SSM8V	SSM8V	SSM8V	SSM8V	SSM8V	-	SSM8V	-
	110	SPR5J	SSM8V	SPR5V	SSM8V	SSM8V	SSM8V	SSM8V	SSM8V	SSM8V	-
	100	SPR5J	SPR5V	SPR5J	SPR5V	SPR5V	SSM8V	SPR5V	SSM8V	SSM8V	SSM8V
	90	SPR5J	SPR5J	SPR5J	SPR5V	SPR5J	SPR5V	SPR5V	SSM8V	SSM8V	SSM8V
	80	ATR85N	SPR5J	SPR5J	SPR5J	SPR5J	SPR5V	SPR5J	SPR5V	SPR5V	SSM8V
	70	ATR85N	ATR85N	ATR85N	SPR5J	ATR85N	SPR5J	SPR5J	SPR5J	SPR5J	SPR5V

PV Panels with 50° tilt		(h) Total Pole Height (ft) – Aluminum & Steel Poles									
		18		19-20		21-22		23-24		25-27	
		200w	325w	200w	325w	200w	325w	200w	325w	200w	325w
Wind Speed (MPH)	150	SSM8V	-	SSM8V	-	-	-	-	-	-	-
	140	SSM8V	SSM8V	SSM8V	-	SSM8V	-	-	-	-	-
	130	SSM8V	SSM8V	SSM8V	SSM8V	SSM8V	-	SSM8V	-	-	-
	120	SSM8V	SSM8V	SSM8V	SSM8V	SSM8V	-	SSM8V	-	-	-
	110	SPR5V	SSM8V	SPR5V	SSM8V	SSM8V	SSM8V	SSM8V	SSM8V	SSM8V	-
	100	SPR5J	SPR5V	SPR5V	SSM8V	SPR5V	SSM8V	SSM8V	SSM8V	SSM8V	-
	90	SPR5J	SPR5V	SPR5J	SPR5V	SPR5V	SSM8V	SPR5V	SSM8V	SSM8V	SSM8V
	80	SPR5J	SPR5J	SPR5J	SPR5J	SPR5J	SPR5V	SPR5J	SSM8V	SPR5V	SSM8V
	70	ATR85N	SPR5J	ATR85N	SPR5J	SPR5J	SPR5J	SPR5J	SPR5V	SPR5J	SPR5V

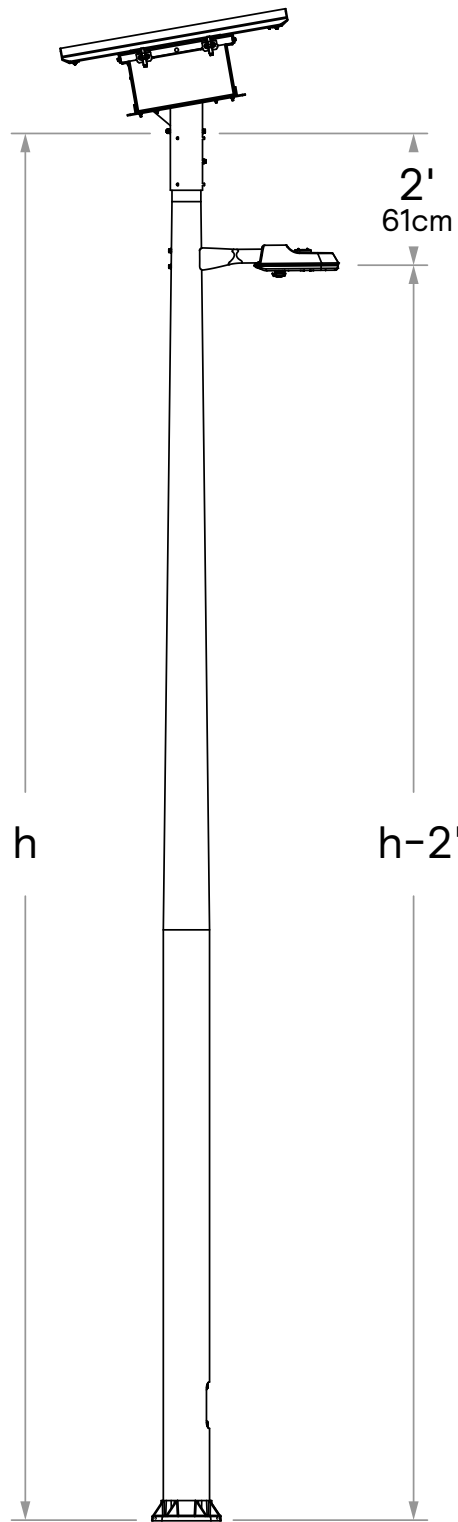



# RPS-SOL RoadFocus Plus

Smart solar powered system

## Dimensions

Bottom View (20-30-40 LEDs)

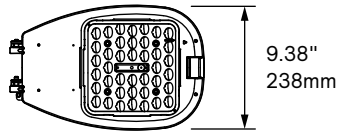

Side View

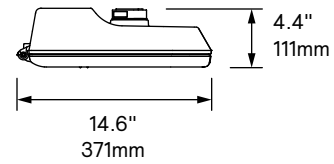

**Weight:** 8.8 lbs  
**EPA:** 0.17 sq. feet

Post-Top Solar Subassembly Tenon (for all versions)

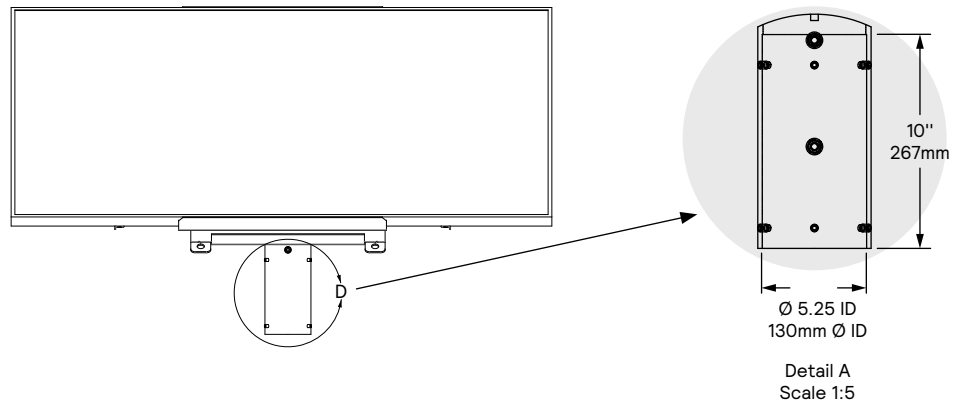

# RPS-SOL RoadFocus Plus

Smart solar powered system

## Dimensions (2.1 with 200Wp PV Panel)

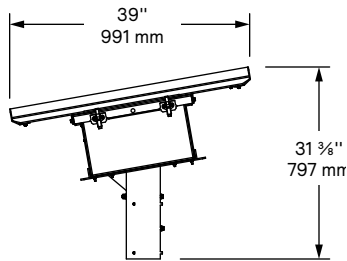
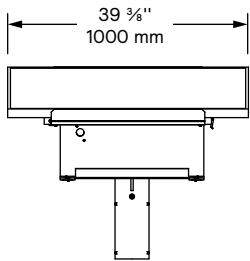

### Post-Top Solar Subassembly With 200Wp PV Panel

- Tilt: 10°
- EPA: 2.65 sq. feet
- Max Weight: 256.3 lbs

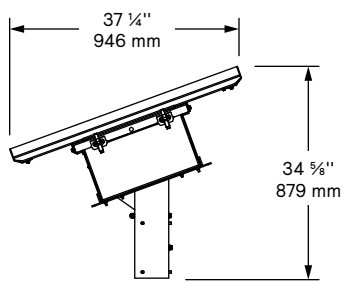
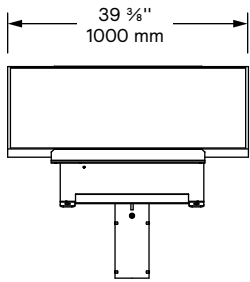

### Post-Top Solar Subassembly With 200Wp PV Panel

- Tilt: 20°
- EPA: 3.79 sq. feet
- Max Weight: 256.3 lbs

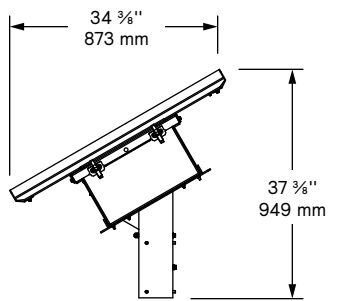
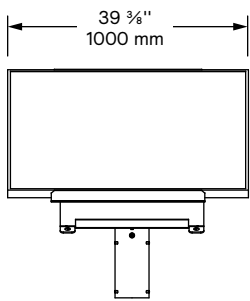

### Post-Top Solar Subassembly With 200Wp PV Panel

- Tilt: 30°
- EPA: 5.50 sq. feet
- Max Weight: 256.3 lbs

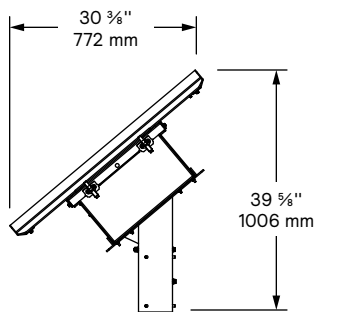
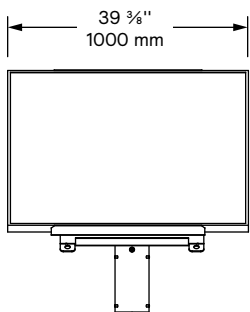

### Post-Top Solar Subassembly With 200Wp PV Panel

- Tilt: 40°
- EPA: 8.00 sq. feet
- Max Weight: 256.3 lbs

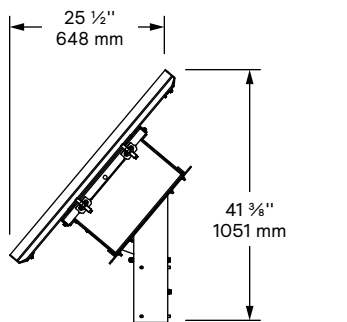
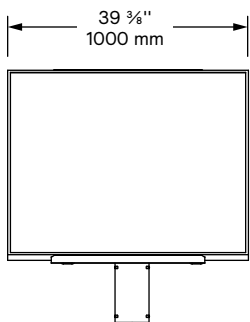

### Post-Top Solar Subassembly With 200Wp PV Panel

- Tilt: 50°
- EPA: 9.73 sq. feet
- Max Weight: 256.3 lbs

# RPS-SOL RoadFocus Plus

Smart solar powered system

## Dimensions (2.2 with 325Wp PV Panel)

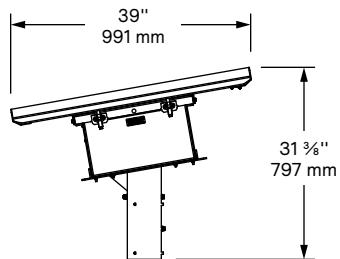
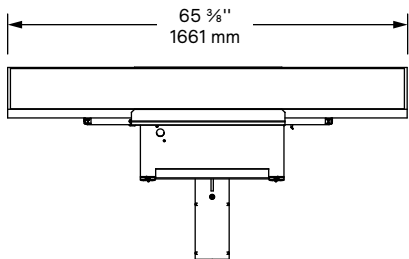

### Post-Top Solar Subassembly With 325Wp PV Panel

- Tilt: 10°
- EPA: 3.57 sq. feet
- Max Weight: 273 lbs

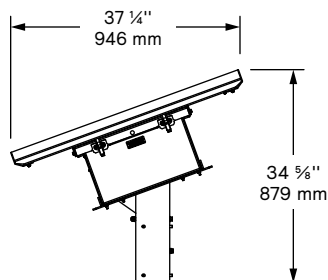
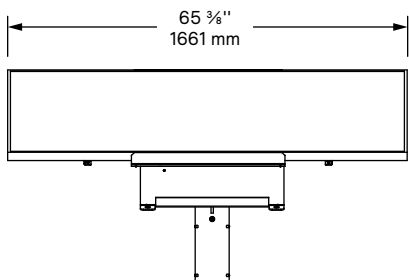

### Post-Top Solar Subassembly With 325Wp PV Panel

- Tilt: 20°
- EPA: 5.70 sq. feet
- Max Weight: 273 lbs

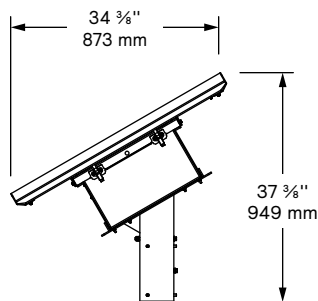
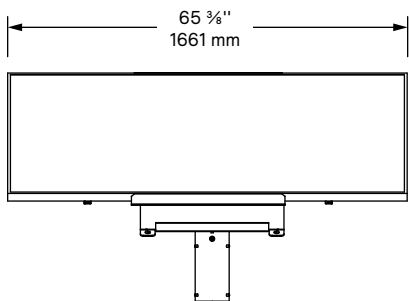

### Post-Top Solar Subassembly With 325Wp PV Panel

- Tilt: 30°
- EPA: 7.90 sq. feet
- Max Weight: 273 lbs

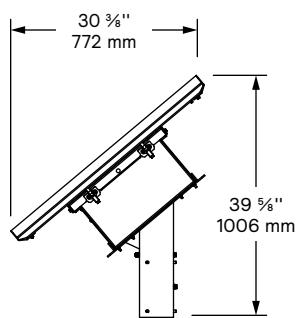
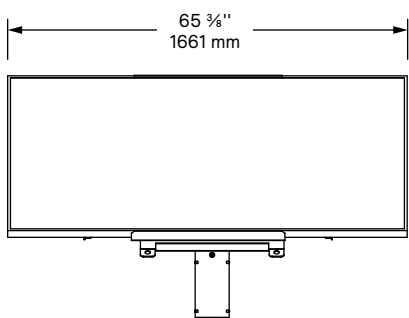

### Post-Top Solar Subassembly With 325Wp PV Panel

- Tilt: 40°
- EPA: 11.93 sq. feet
- Max Weight: 273 lbs

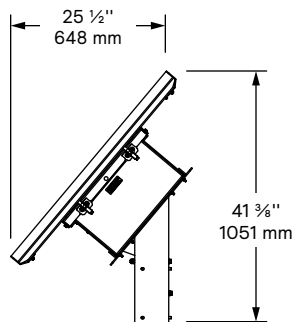
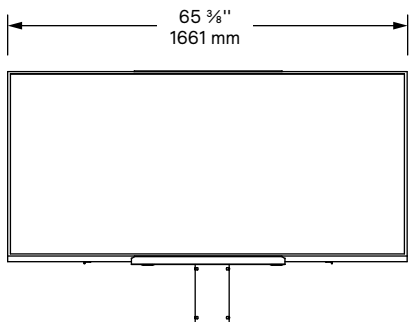

### Post-Top Solar Subassembly With 325Wp PV Panel

- Tilt: 50°
- EPA: 14.84 sq. feet
- Max Weight: 273 lbs

# RPS-SOL RoadFocus Plus

## Smart solar powered system

### Technical Specifications

#### Luminaire Subassembly

Product Family	RoadFocus Plus
Lumen Output Range	5,000 up to 12,000
CCT	2700K, 3000K, 4000K
Distribution	R2M, R2MB, R2S, R3M, R3MB, R3S, 4, 5
Motion Sensor	Optional (MR)
Weight (lbs)	6.9
Operating Temperature	-40 to +122°F / -40 to +50°C
IP Rating	Housing: IP54 / Light Engine: IP66

#### Solar Module Subassembly

PV Panels Nomenclature	P200	P325
Total Power	200Wp	325Wp
Dimensions (in)	39.41 x 39.41 x 1.38	65.4 x 39.41 x 1.38
Weight (lbs)	28.32	40.78
Module Type	Monocrystalline Silicon Solar Cells	
Panel Mount	Anodized aluminum extrusion	
Tilting Angles	Factory pre-tilted: 10, 20, 30, 40 or 50°	
Operating Temperature	-40 to 185°F / -40 to +85°C	

#### Battery / Controller Subassembly

Battery Chemistry	Lead Crystal		
Battery Nomenclature	CB1	CB2	CB3
Capacity (AH)	40AH	70AH	100AH
Capacity (WH)	960Wh	1,680Wh	2,400Wh
Total Subassembly Weight (lbs)	175	216	273
Total Subassembly Dimensions (in)	26.9 X 19.5 X 10.2		
Battery Voltage	24V (2x12V)		
Battery Charge Temperature	-30 to +149°F / -35 to +65°C		
Battery Discharge Temperature	-30 to +149°F / -35 to +65°C		
Enclosure Material	Aluminum & Steel base		
Mounting	Post-Top		
Post-Top Tenon Inner Diameter	5 1/8"		

#### Charge Controller / LED Driver

Charging Type	MPPT	
LED Driver Type	High-efficiency integrated LED driver	
LED Wattage Range	2.5W to 100W	
Configurable	Yes	
Operating Profiles	Programmable up to 5 steps Dusk to dawn	
Run Time Extension	Enabled	
Operating Temperature	-30 to +122°F / -35 to +50°C	
Mobile App Data Monitoring	LED voltage, current	Battery voltage, current
	PV voltage, current	Battery temperature
Mobile App Fault Status Monitoring	Load short circuit	Board overtemperature
	Load disconnected	PV overvoltage
	Battery undervoltage, overvoltage, overtemperature	

#### Poles (see poles selection charts in page 7)

Pole Material	Aluminum	Steel
Product Families	ATR85N	SSM8V / SPR5V / SPR5J
Luminaire Mounting Height	16' up to 25'	
Total Pole Height	18' up to 27'	
Max Wind Speed	Up to 150 MPH (check pages 7 and 8)	

#### Arm

Product Family	RLARS
Configuration	1 arm side mounted
Pole Interface	R5@6 (for 5" to 6" round poles)

#### Certification and Compliance

Luminaire	cULUS listed for USA and Canada CCT 2700K & 3000K are Dark Sky approved
PV Panels	UL 61730 / IEC 61215:2016 / IEC 61730-1 & 2:2016
Battery	UL 1989 / IEC 60896-21 / IEC 60896-22
Charge Controller	UL 1741 / UL 8750 / IEC 62109-1 / IEC 61547 / IEC 61347 / CISPR 15
Poles	Compliant with AASHTO 2001 and CSA AAMA 2603 / ASTM D2244 / ASTM D523 / ASTM D2247
Whole System	UL 8801

#### Limited Warranty

Luminaire	RoadFocus Plus – 10 years
PV Panel	5 years
Battery	5 years
Charge Controller	5 years
Poles	Aluminum – 5 years / Steel – 3 years

# RPS-SOL RoadFocus Plus

## Smart solar powered system

### Specifications

#### Housing

Made of a low copper die cast Aluminum alloy (A360), 0.100" (2.5mm) minimum thickness. Fits on a 1.66" (42mm) O.D. (1.25" NPS), 1.9" (48mm) O.D. (1.5" NPS) or 2 3/8" (60mm) O.D. (2" NPS) by 5 1/2" (140mm) minimum long tenon. Comes with a zinc plated clamp fixed by 2 zinc plated hexagonal bolts 3/8 16 UNC for ease of installation. Provides an easy step adjustment of +/- 5° tilt in 2.5° increments. Includes integral bubble level standard (always included). A quick release, tool less entry, single latch, hinged, removable door opens downward to provide access to electronic components and to a terminal block. Door is secured to prevent accidental dropping or disengagement. A clearance of 13" (330mm) at the rear is required in order to remove the door. Complete with a bird guard protecting against birds and similar intruders and an ANSI label as per C136.15 2020 to identify wattage and source (both included in box).

#### Light Engine

Composed of 3 main components; Heat Sink / LED Module / Optical System. Electrical components are RoHS compliant, IP66 sealed light engine. LEDs tested by ISO 17025 2005 accredited lab in accordance with IESNA LM 80 guidelines, extrapolations in accordance with IESNA TM 21. Metal core board ensures greater heat transfer and longer lifespan.

#### LED Module

Composed of high-performance white LEDs. Color temperature as per ANSI/NEMA bin 2700 Kelvin nominal (2725 ±145K), 3000 Kelvin nominal (3045K +/- 175K) or 4000 Kelvin nominal (3985K +/- 275K), CRI 70 Min. 75 Typical. Other CCT/CRI also available, consult factory

#### Optical System

Composed of high performance UV stabilized optical grade polymer refractor lenses to achieve desired distribution optimized to get maximum spacing, target lumens and a superior lighting uniformity. System is rated IP66. Performance shall be tested per LM 63, LM 79 and TM 15 (IESNA) certifying its photometric performance.

#### Heat Sink

Built in the housing, designed to ensure high efficacy and superior cooling by natural vertical convection air flow pattern always close to LEDs and driver optimising their efficiency and life. Product does not use any cooling device with moving parts (only passive cooling). Entire luminaire is rated for operation in ambient temperature of 40°C / 40°F up to +40°C / +104°F.

#### Wiring

The connection of the luminaire is done using a terminal block connector 600V, 85A for use with #2 14 AWG. wires from the primary circuit, located inside the housing.

#### Hardware

All exposed screws shall be complete with Ceramic primer seal basecoat to reduce seizing of the parts and offers a high resistance to corrosion. All seals and sealing devices are made and/or lined with EPDM and/or silicone and/or rubber.

#### Factory Installed Shield options

(one per Light Engine)

**CSS:** Cul-de-Sac Shield. Shields light output on the left and right side of fixture.

**FSS:** Front Side Shield. Shields light output on the front side of fixture.

**HSS:** House Side Shield. Shields light output to the back side of fixture.

**LSS:** Left Side Shield. Shields light output on the left side of fixture.

**RSS:** Right Side Shield. Shields light output on the right side of fixture.

#### Luminaire Useful Life

Refer to IES files for energy consumption and delivered lumens for each option. Based on ISTMT in situ thermal testing in accordance with UL1598 and UL8750, System Reliability Tool. Advance data and LED manufacturer LM 80/TM 21 data, expected to reach 100,000 + hours with >L70 lumen maintenance @ 25°C. Luminaire Useful Life accounts for LED lumen maintenance AND all of these additional factors including: LED life, driver life, PCB substrate, solder joints, on/off cycles, burning hours and corrosion.

#### Luminaire Options

**Motion Response (MR):** Motion Response module is mounted integral to luminaire and system is factory pre-programmed and can be updated at the site.

**2C:** Two zinc plated clamps fixed by 4 zinc plated hexagonal bolts 3/8 16 UNC for ease of installation

#### Finish

Color in accordance with the AAMA 2603 standard. Application of polyester powder coat paint (4 mils/100 microns) with ± 1 mils/24 microns of tolerance. The Thermosetting resins provides a discoloration resistant finish in accordance with the ASTM D2244 standard, as well as luster retention in keeping with the ASTM D523 standard and humidity proof in accordance with the ASTM D2247 standard. The surface treatment achieves a minimum of 5000 hours for salt spray resistant finish in accordance with testing performed and per ASTM B117 standard.

#### LED products manufacturing standard

The electronic components sensitive to electrostatic discharge (ESD) such as light emitting diodes (LEDs) are assembled in compliance with IEC61340-5-1 and ANSI/ESD S20.20 standards so as to eliminate ESD events that could decrease useful life of the product.

**Note:** Please note that door of the RPS SOL cannot be removed when luminaire is installed on this bracket.

**Arm:** (RLARS) Made of cast A356 aluminum, mechanically assembled to the pole.

**Solar Panel:** 200W or 325W Solar panels with fixed tilt angle 10°, 20°, 30°, 40° or 50° mounted on a steel frame mechanically assembled on an aluminum box c/w door with hinge and latch giving a tool free access to the Crystal battery, charge controller and wiring. Enclosure is rated IP54.

**Pole Shaft:** Shall be made from a 5" (127mm) round high tensile carbon steel tubing, having a 0.250" (6.4mm) wall thickness, welded to both the bottom and top of the anchor plate.

**Maintenance Opening:** The pole shall have a 2" x 4 1/2" (51mm x 114mm) maintenance opening centered 20" (508mm) from the bottom of the anchor plate, complete with a weatherproof aluminum cover and a copper ground lug.

**Base Cover:** Two piece square base cover made from formed aluminum, mechanically fastened with stainless steel screws.

**Important:** Lumecc strongly recommends the installation of the complete lighting assembly with all its accessories upon the anchoring of the pole. This will ensure that the structural integrity of the product is maintained throughout its lifetime.

**Anchor Bolts:** Anchor bolts made of ASTM F1554 grade 55 steel with a minimum yield strength of 55,000 psi. Nuts made of ASTM F1554 99 grade A steel or better. The thread adjustment is ANSI class 2B regardless of the diameter of the bolts. Washers made of ASTM grade F 844 steel or better. All galvanized parts are hot dip galvanized with minimum requirement the ACNOR G 164 standard.

**Note:** Ground rod must be provided and installed by contractor as per National Electrical code (NEC) article 250.52 (A)(5) or the local application regulation agency.

#### Vibration Resistance

The RPS SOL meets the ANSI C136.31 2018, American National Standard for Roadway Luminaire Vibration specifications for normal applications.

#### Mechanical resistance

This design information is intended as a general guideline only. The customer is solely responsible for proper selection of pole, luminaire, accessories and foundation under the given site conditions and intended usage. The addition of any other item to the pole may dramatically impact the wind load on that pole. It is strongly recommended that a qualified professional be consulted to analyze the loads given the user's specific needs to ensure proper selection of the pole, luminaire, accessories, and foundation. Lumecc assumes no responsibility for such complete analysis or product selection. Failure to ensure proper site analysis, pole selection, loads and installation can result in pole failure, leading to serious injury or property damage.