



Gardco OptiForm site and area luminaires are available in three sizes: small, medium and large. Featuring the latest in LED technology, OptiForm achieves up to 192 lumens per watt. Eleven optical distributions are available, suitable for a range of outdoor lighting applications. OptForm features a unique mounting system with a two-piece housing for hassle-free installation. Mounting options include a standard arm, mast arm, and wall mount bracket. Service Tag is a standard feature with every OptiForm luminaire, providing maintenance or upgrade assistance throughout the life of the product.

Project: _____
 Location: _____
 Cat.No: _____
 Type: _____
 Lamps: _____ Qty: _____
 Notes: _____

Ordering guide

example: OPF-S-A01-840-T4M-AR1-120-BL50-L3-BZ

Luminaire	Configuration (nom. lumens)		Color Temperature	Distribution		Mounting	Voltage
OPF-S							
OPF-S OptiForm Small Area	Site and Area	Precision Plus¹⁶ (T2M, T3M, T4M, T5M only)	827¹ 80CRI 2700K 830 80CRI 3000K 840 80CRI 4000K 727¹ 70CRI 2700K 730 70CRI 3000K 740 70CRI 4000K 750 70CRI 5000K	AFR Autofront row T2M Type 2 medium T3M Type 3 medium T4M Type 4 medium T4W Type 4 wide T5N Type 5 narrow T5M Type 5 medium T5W Type 5 wide	LCL LEED corner optic left LCR LEED corner optic right BLC Back light control 2RL Type 2 rotated left 90° 2RR Type 2 rotated right 270° 3RL Type 3 rotated left 90° 3RR Type 3 rotated right 270° 4RL¹ Type 4 rotated left 90° 4RR¹ Type 4 rotated right 270°	AR^{12,17} Arm mount (standard) MAR³ Mast arm WAL Wall mount MOS⁴ Mounting ordered separately	120 120V 208 208V 240 240V 277 277V 347 347V 480 480V UNV 120-277V HVU¹⁶ 347-480V
	A01 7,000 lumens A02 9,000 lumens A03 11,000 lumens A04 15,000 lumens A05 17,000 lumens A06 19,000 lumens A07 20,000 lumens	P01 2,500 lumens P02 4,000 lumens P03 6,500 lumens P04 9,000 lumens P05 11,500 lumens P06 14,000 lumens P07 16,500 lumens P08 19,000 lumens P09 22,000 lumens					

Dimming Controls	Sensing	Options (electrical, mechanical, etc)	Emergency	Finish
The following options include 0-10V Driver		None Surge protector 10kV/10kA standard SP2 Surge protector 20kV/10kA (option) FS1¹¹ Single fuse (120, 277, or 347VAC) FS2¹¹ Double fuse (208, 240, or 480V) PCB^{11,12} Photocontrol button connected to 0-10V driver TR5 NEMA Twist-lock 5-pin receptacle connected to 0-10V driver TR7¹³ 7-pin twist lock receptacle connected to D4i compliant driver TLP^{11,13} 7-pin twist lock receptacle connected to D4i compliant driver w/ 3-pin photocell EHS Housing machined to accept external house side shield for field install. Must be combined with OPF-S-EHS-1 accessory. BAC¹¹⁸ Meets the requirements of the Buy American Act of 1933 (BAA)	EM^{12,14,15} Emergency Battery Pack (0-40 °C) Available with precision plus optics P01-P03 only	Standard textured finish BK Black WH White BZ Bronze DG Dark Gray MG Medium Gray Customer specified OC Special optional color or RAL, consult factory SC Special color (must supply color chip, requires factory quote)
none 0-10V dimming driver DLEA^{5,10} Dimming leads externally accessible (controls by others) FAWS^{5,6,10} Field adjustable wattage selector BL50^{5,7,10} Bi-level with motion sensor	L2 PIR sensor, #2 lens (Required if BL50 is selected) WIAP sensor options LB Low (7'-15' mounting height) sensor, black color housing, wireless Interact, integral LW Low (7'-15' mounting height) sensor, white color housing HB High (15'-40' mounting height) sensor, black color housing HW High (15'-40' mounting height) sensor, white color housing			
The following options include SR/DALI Driver				
WIAP^{5,8,13} Wireless Interact (includes SR drive and SR receptacle) SRDR^{5,8,13} SR driver connected to Zhaga socket (D4i) DynaDimmer: Automatic Profile Dimming CS50^{5,13} Security 50% dimming, 7 hours CM50^{5,13} Median 50% dimming, 8 hours CS30^{5,13} Security 30% dimming, 7 hours CM30^{5,13} Median 30% dimming, 8 hours				

- Extended leadtime applies. Consult factory for details.
- Mounts to a square pole with knockout for 4-5" OD round pole.
- Mounts to a horizontal 2-3/8" OD x 5" Long tenon.
- Must be ordered with mounting accessory. Photocell option (TR7) must be selected with mounting accessory. See Page 2 for options.
- Not available with other dimming control options (mutually exclusive).
- Not available with motion sensor (physical restriction).
- Must be specified with a motion sensor lens (L2).
- Not available with PCB, TR5.
- Must be specified with a motion sensor LW, LB.
- Not available with TR7, TLP.
- Must specify input voltage.
- Not available in HVU [347-480V].
- UNV [120-277V] only available for lumen packages P03-P09. HVU [347-480V] only available for lumen packages P06-P09 & A04-A07.
- Not available for lumen packages P04-P09.
- Not available with Dynadimmer, SRDR, FAWS, FS1, FS2, DLEA, BL50 (physical restriction).
- Precision Plus Optics (P01-P09) available only with T2M, T3M, T4M, and T5M optical distributions and are non-rotatable.
- OPF-RMB accessory recommended for retrofit applications.
- Failure to properly select the "BAC" suffix could result in you receiving product that is not BAA compliant product with no recourse for an RMA or refund. This BAC designation hereunder does not address (i) the applicability of, or availability of a waiver under, the Trade Agreements Act, or (ii) the "Buy America" domestic content requirements imposed on states, localities, and other non-federal entities as a condition of receiving funds administered by the Department of Transportation or other federal agencies.

OPF-S OptiForm small

Site & area luminaire

Shielding Accessory Kits (order separately)

One shield kit per luminaire

- OPF-S-EHS-1*** External house side shield (field installed)
- OPF-S-HIS-1**** Internal house side shields. For Area optic types T2M, T3M, and T5N.
- OPF-S-HIS-T4-1**** Internal house side shield for Area optic types T4M and T4W, qty 1.
- OPF-S-HIS-5M/5W-1**** Internal house side shield for Area optic types T5M and T5W, qty 1

*Must select EHS option on luminaire options section

**Not available for Precision Plus (P01-P09)

Luminaire Accessories (order separately)

Pole Mount Fusing

- FP1** Pole mount single fuse (120V, 277V, or 347V)
- FP2** Pole mount double fuse (208V, 240V, or 480V)
- FP3** Pole mount double fuse canadian double pull (208V, 240V, or 480V)

Photocell Accessories

- P400S** Shorting cap

Mountings (boxed and shipped separately)

Must choose Mounting Ordered Separately (MOS) selection for mounting option of luminaire. Useful for attachment of arm to pole prior to luminaire installation.

Standard Arm

- OPF-AR1-(F)^{2,17}** Standard arm mount
- OPF-AR1-TR7-(F)^{2,13,17}** Mast arm mount with 7-pin (TR7) receptacle

Wall Mount

- OPF-WAL-(F)** Wall mount bracket
- OPF-WAL-TR7-(F)¹³** Wall mount with 7-pin (TR7) receptacle

Mast Arm

- OPF-MAR-(F)³** Mast arm mount
- OPF-MAR-TR7-(F)^{3,13}** Mast arm mount with 7-pin (TR7) receptacle

Optical Distributions

Site and Area Optics

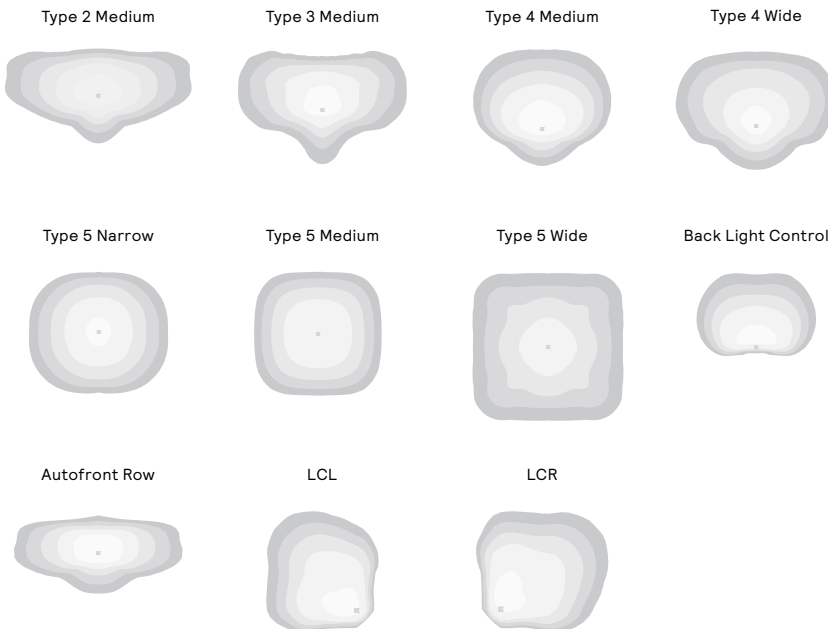

Precision Plus Optics

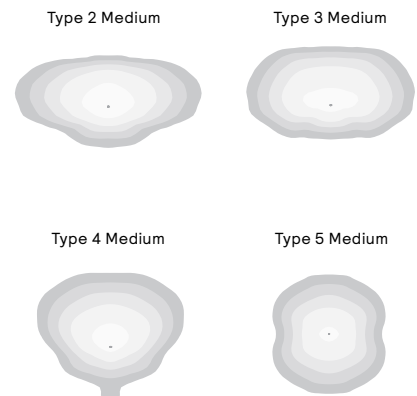

Mounting Accessories

OPF-RMB Retrofit Mounting Bolster Plate for attaching OptiForm to existing poles. Recommended for retrofit applications.

OPF-RPA Round Pole Adapter. Fits to 3"- 3.9" O.D. pole. Painted black.

Pole Top Fitters

PTF2 - Pole top fitter fits 2 3/8 - 2 1/2" OD x 4" depth tenon

- PTF2-1-90-(F)** 1 luminaire at 90°
- PTF2-2-90-(F)** 2 luminaires at 90°
- PTF2-3-90-(F)** 3 luminaires at 90°
- PTF2-4-90-(F)** 4 luminaires at 90°
- PTF2-2-180-(F)** 2 luminaires at 180°
- PTF2-3-120-(F)** 3 luminaires at 120°

PTF3 - Pole top fitter fits 3-3 1/2" OD x 6" depth tenon

- PTF3-1-90-(F)** 1 luminaire at 90°
- PTF3-2-90-(F)** 2 luminaires at 90°
- PTF3-3-90-(F)** 3 luminaires at 90°
- PTF3-4-90-(F)** 4 luminaires at 90°
- PTF3-2-180-(F)** 2 luminaires at 180°
- PTF3-3-120-(F)** 3 luminaires at 120°

OPF-S OptiForm small

Site & area luminaire

OPF-S Area Optic Lumen values

Performance Package	System Watts	Distribution Type	70 CRI			70 CRI			70 CRI		
			3000K			4000K			5000K		
			Lumen Output	BUG Rating	Efficacy (LPW)	Lumen Output	BUG Rating	Efficacy (LPW)	Lumen Output	BUG Rating	Efficacy (LPW)
A01	42	T2M	6991	B2-U0-G2	167	7391	B2-U0-G2	176	7391	B2-U0-G2	176
		T3M	6935	B2-U0-G2	166	7332	B2-U0-G2	175	7332	B2-U0-G2	175
		T4M	7028	B1-U0-G2	168	7431	B1-U0-G2	177	7431	B1-U0-G2	177
		T5M	7244	B3-U0-G1	173	7659	B3-U0-G1	183	7659	B3-U0-G1	183
		AFR	7241	B2-U0-G2	173	7655	B2-U0-G2	183	7655	B2-U0-G2	183
		T4W	6692	B1-U0-G2	160	7075	B1-U0-G2	169	7075	B1-U0-G2	169
		T5N	7193	B3-U0-G1	172	7605	B3-U0-G1	182	7605	B3-U0-G1	182
		T5W	6926	B3-U0-G2	165	7322	B3-U0-G2	175	7322	B3-U0-G2	175
		LCL	3804	B1-U0-G1	91	4021	B1-U0-G1	96	4021	B1-U0-G1	96
		LCR	3804	B1-U0-G1	91	4021	B1-U0-G1	96	4021	B1-U0-G1	96
BLC	4874	B0-U0-G1	116	5153	B0-U0-G1	123	5153	B0-U0-G1	123		
A02	54	T2M	8941	B2-U0-G2	165	9452	B2-U0-G2	175	9452	B2-U0-G2	175
		T3M	8869	B2-U0-G2	164	9377	B2-U0-G2	173	9377	B2-U0-G2	173
		T4M	8989	B1-U0-G2	166	9503	B1-U0-G2	176	9503	B1-U0-G2	176
		T5M	9265	B3-U0-G2	171	9795	B3-U0-G2	181	9795	B3-U0-G2	181
		AFR	9260	B2-U0-G2	171	9790	B2-U0-G2	181	9790	B2-U0-G2	181
		T4W	8558	B2-U0-G2	158	9048	B2-U0-G2	167	9048	B2-U0-G2	167
		T5N	9200	B3-U0-G1	170	9726	B3-U0-G1	180	9726	B3-U0-G1	180
		T5W	8858	B3-U0-G2	164	9365	B3-U0-G2	173	9365	B3-U0-G2	173
		LCL	4864	B1-U0-G1	90	5143	B1-U0-G1	95	5143	B1-U0-G1	95
		LCR	4864	B1-U0-G1	90	5143	B1-U0-G1	95	5143	B1-U0-G1	95
BLC	6234	B0-U0-G2	115	6591	B0-U0-G2	122	6591	B0-U0-G2	122		
A03	54	T2M	10438	B2-U0-G2	164	11035	B2-U0-G2	174	11035	B3-U0-G3	174
		T3M	10354	B2-U0-G2	163	10947	B2-U0-G2	172	10947	B2-U0-G2	172
		T4M	10494	B2-U0-G2	165	11094	B1-U0-G2	174	11094	B2-U0-G2	174
		T5M	10816	B3-U0-G2	170	11435	B3-U0-G2	180	11435	B3-U0-G2	180
		AFR	10811	B3-U0-G3	170	11429	B2-U0-G2	180	11429	B3-U0-G3	180
		T4W	9991	B2-U0-G3	157	10563	B2-U0-G2	166	10563	B2-U0-G3	166
		T5N	10740	B3-U0-G2	169	11355	B3-U0-G1	179	11355	B3-U0-G2	179
		T5W	10341	B4-U0-G2	163	10933	B3-U0-G2	172	10933	B4-U0-G2	172
		LCL	5679	B1-U0-G1	89	6004	B1-U0-G1	94	6004	B1-U0-G1	94
		LCR	5679	B1-U0-G1	89	6004	B1-U0-G1	94	6004	B1-U0-G1	94
BLC	7278	B1-U0-G2	114	7694	B0-U0-G2	121	7694	B1-U0-G2	121		
A04	91	T2M	14465	B3-U0-G3	160	15293	B3-U0-G3	169	15293	B3-U0-G3	169
		T3M	14350	B3-U0-G3	158	15171	B3-U0-G3	167	15171	B3-U0-G3	167
		T4M	14543	B2-U0-G2	160	15375	B2-U0-G2	170	15375	B2-U0-G2	170
		T5M	14990	B4-U0-G2	165	15848	B4-U0-G2	175	15848	B4-U0-G2	175
		AFR	14982	B3-U0-G3	165	15840	B3-U0-G3	175	15840	B3-U0-G3	175
		T4W	13847	B2-U0-G3	153	14639	B2-U0-G3	161	14639	B2-U0-G3	161
		T5N	14884	B4-U0-G2	164	15736	B4-U0-G2	174	15736	B4-U0-G2	174
		T5W	14331	B4-U0-G3	158	15151	B4-U0-G3	167	15151	B4-U0-G3	167
		LCL	7870	B1-U0-G2	87	8321	B1-U0-G2	92	8321	B1-U0-G2	92
		LCR	7870	B1-U0-G2	87	8321	B1-U0-G2	92	8321	B1-U0-G2	92
BLC	10086	B1-U0-G2	111	10663	B1-U0-G2	118	10663	B1-U0-G2	118		

OPF-S OptiForm small

Site & area luminaire

OPF-S Area Optic Lumen values (cont'd)

Performance Package	System Watts	Distribution Type	70 CRI			70 CRI			70 CRI		
			3000K			4000K			5000K		
			Lumen Output	BUG Rating	Efficacy (LPW)	Lumen Output	BUG Rating	Efficacy (LPW)	Lumen Output	BUG Rating	Efficacy (LPW)
A05	104	T2M	16226	B3-U0-G3	156	17155	B3-U0-G3	164	17155	B3-U0-G3	164
		T3M	16096	B3-U0-G3	154	17018	B3-U0-G3	163	17018	B3-U0-G3	163
		T4M	16313	B2-U0-G3	156	17247	B2-U0-G3	165	17247	B2-U0-G3	165
		T5M	16814	B4-U0-G2	161	17777	B4-U0-G2	170	17777	B4-U0-G2	170
		AFR	16806	B3-U0-G3	161	17768	B3-U0-G3	170	17768	B3-U0-G3	170
		T4W	15532	B3-U0-G3	149	16421	B3-U0-G3	157	16421	B3-U0-G3	157
		T5N	16696	B4-U0-G2	160	17652	B4-U0-G2	169	17652	B4-U0-G2	169
		T5W	16075	B4-U0-G3	154	16995	B4-U0-G3	163	16995	B4-U0-G3	163
		LCL	8828	B1-U0-G2	85	9333	B1-U0-G2	89	9333	B1-U0-G2	89
		LCR	8828	B1-U0-G2	85	9333	B1-U0-G2	89	9333	B1-U0-G2	89
BLC	11314	B1-U0-G2	108	11961	B1-U0-G2	115	11961	B1-U0-G2	115		
A06	122	T2M	18441	B3-U0-G3	151	19496	B3-U0-G3	160	19496	B3-U0-G3	160
		T3M	18294	B3-U0-G3	150	19341	B3-U0-G3	158	19341	B3-U0-G3	158
		T4M	18540	B3-U0-G3	152	19601	B3-U0-G3	160	19601	B3-U0-G3	160
		T5M	19110	B4-U0-G2	156	20203	B4-U0-G2	165	20203	B4-U0-G2	165
		AFR	19100	B3-U0-G3	156	20193	B3-U0-G3	165	20193	B3-U0-G3	165
		T4W	17652	B3-U0-G3	144	18662	B3-U0-G3	153	18662	B3-U0-G3	153
		T5N	18975	B4-U0-G2	155	20061	B4-U0-G2	164	20061	B4-U0-G2	164
		T5W	18270	B5-U0-G3	150	19315	B5-U0-G3	158	19315	B5-U0-G3	158
		LCL	10033	B2-U0-G2	82	10607	B2-U0-G2	87	10607	B2-U0-G2	87
		LCR	10033	B2-U0-G2	82	10607	B2-U0-G2	87	10607	B2-U0-G2	87
BLC	12858	B1-U0-G2	105	13594	B1-U0-G2	111	13594	B1-U0-G2	111		
A07	136	T2M	16776	B3-U0-G3	123	20034	B3-U0-G3	147	21181	B3-U0-G3	156
		T3M	16642	B3-U0-G3	122	19874	B3-U0-G3	146	21012	B3-U0-G3	154
		T4M	16866	B2-U0-G3	124	20142	B3-U0-G3	148	21294	B3-U0-G3	156
		T5M	17384	B4-U0-G2	128	20761	B4-U0-G2	152	21949	B4-U0-G2	161
		AFR	17375	B3-U0-G3	128	20750	B3-U0-G3	152	21938	B3-U0-G3	161
		T4W	16058	B3-U0-G3	118	19178	B3-U0-G3	141	20275	B3-U0-G3	149
		T5N	17262	B4-U0-G2	127	20615	B4-U0-G2	151	21794	B4-U0-G2	160
		T5W	16620	B4-U0-G3	122	19848	B5-U0-G3	146	20984	B5-U0-G3	154
		LCL	9127	B1-U0-G2	67	10900	B2-U0-G2	80	11524	B2-U0-G2	85
		LCR	9127	B1-U0-G2	67	10900	B2-U0-G2	80	11524	B2-U0-G2	85
BLC	11697	B1-U0-G2	86	13969	B1-U0-G2	103	14768	B1-U0-G2	108		

OPF-S OptiForm small

Site & area luminaire

OPF-S Precision Plus Optic Lumen values

Performance Package	System Watts	Distribution Type	70 CRI			70 CRI			70 CRI		
			3000K			4000K			5000K		
			Lumen Output	BUG Rating	Efficacy (LPW)	Lumen Output	BUG Rating	Efficacy (LPW)	Lumen Output	BUG Rating	Efficacy (LPW)
P01	15	T2M	2691	B1-U0-G1	182	2845	B1-U0-G1	192	2845	B1-U0-G1	192
		T3M	2718	B1-U0-G1	184	2874	B1-U0-G1	194	2874	B1-U0-G1	194
		T4M	2665	B1-U0-G1	180	2817	B1-U0-G1	190	2817	B1-U0-G1	190
		T5M	2610	B2-U0-G1	176	2759	B2-U0-G1	186	2759	B2-U0-G1	186
P02	23	T2M	4022	B1-U0-G1	178	4252	B1-U0-G1	189	4252	B1-U0-G1	189
		T3M	4062	B1-U0-G1	180	4295	B1-U0-G1	191	4295	B1-U0-G1	191
		T4M	3983	B1-U0-G1	177	4211	B1-U0-G1	187	4211	B1-U0-G1	187
		T5M	3900	B2-U0-G1	173	4124	B2-U0-G1	183	4124	B2-U0-G1	183
P03	38	T2M	6465	B2-U0-G2	169	6835	B2-U0-G2	179	6835	B2-U0-G2	179
		T3M	6530	B2-U0-G2	171	6904	B2-U0-G2	181	6904	B2-U0-G2	181
		T4M	6402	B1-U0-G2	168	6768	B1-U0-G2	177	6768	B1-U0-G2	177
		T5M	6269	B3-U0-G2	164	6629	B3-U0-G2	174	6629	B3-U0-G2	174
P04	53	T2M	8759	B2-U0-G2	165	9261	B2-U0-G2	174	9261	B2-U0-G2	174
		T3M	8848	B2-U0-G2	166	9355	B2-U0-G2	176	9355	B2-U0-G2	176
		T4M	8674	B2-U0-G2	163	9171	B2-U0-G2	172	9171	B2-U0-G2	172
		T5M	8495	B3-U0-G2	160	8982	B3-U0-G2	169	8982	B3-U0-G2	169
P05	66	T2M	11253	B2-U0-G2	172	11898	B2-U0-G2	182	11898	B2-U0-G2	182
		T3M	11366	B3-U0-G3	173	12018	B3-U0-G3	183	12018	B3-U0-G3	183
		T4M	11143	B2-U0-G3	170	11782	B2-U0-G3	180	11782	B2-U0-G3	180
		T5M	10913	B3-U0-G2	167	11539	B3-U0-G2	176	11539	B3-U0-G2	176
P06	76	T2M	13987	B3-U0-G3	183	14788	B3-U0-G3	194	14788	B3-U0-G3	194
		T3M	14128	B3-U0-G3	185	14937	B3-U0-G3	196	14937	B3-U0-G3	196
		T4M	13850	B2-U0-G3	182	14644	B2-U0-G3	192	14644	B2-U0-G3	192
		T5M	13564	B4-U0-G3	178	14342	B4-U0-G3	188	14342	B4-U0-G3	188
P07	94	T2M	15850	B3-U0-G3	168	16758	B3-U0-G3	178	16758	B3-U0-G3	178
		T3M	16010	B3-U0-G3	170	16927	B3-U0-G3	180	16927	B3-U0-G3	180
		T4M	15696	B3-U0-G3	167	16595	B3-U0-G3	176	16595	B3-U0-G3	176
		T5M	15372	B4-U0-G3	163	16253	B4-U0-G3	172	16253	B4-U0-G3	172
P08	113	T2M	19800	B3-U0-G3	176	20934	B3-U0-G3	186	20934	B3-U0-G3	186
		T3M	19999	B3-U0-G3	178	21145	B3-U0-G3	188	21145	B3-U0-G3	188
		T4M	19607	B3-U0-G3	174	20730	B3-U0-G3	184	20730	B3-U0-G3	184
		T5M	19202	B4-U0-G3	171	20302	B4-U0-G3	180	20302	B4-U0-G3	180
P09	133	T2M	21655	B3-U0-G3	163	22896	B3-U0-G3	172	22896	B3-U0-G3	172
		T3M	21874	B3-U0-G3	164	23127	B3-U0-G3	174	23127	B3-U0-G3	174
		T4M	21444	B3-U0-G4	161	22673	B3-U0-G4	171	22673	B3-U0-G4	171
		T5M	21002	B4-U0-G3	158	22205	B4-U0-G3	167	22205	B4-U0-G3	167

OPF-S OptiForm small

Site & area luminaire

LED Wattage and Lumen Values (Emergency Mode)

Ordering Code	CCT	CRI	Avg. System Wattage (W)	Type 2M		Type 3M		Type 4M	
				Lumen Output	BUG Rating	Lumen Output	BUG Rating	Lumen Output	BUG Rating
OPF-S-PXX-740-X-EM	4000	70	6	1000	B0-U0-G0	1014	B0-U0-G1	838	B0-U0-G0
OPF-S-PXX-750-X-EM	5000	70	6	960	B0-U0-G0	973	B0-U0-G1	804	B0-U0-G0
OPF-S-PXX-830-X-EM	3000	80	6	856	B0-U0-G0	868	B0-U0-G1	717	B0-U0-G0
OPF-S-PXX-840-X-EM	4000	80	6	887	B0-U0-G0	899	B0-U0-G1	743	B0-U0-G0

Predicted Lumen Depreciation Data

Predicted performance derived from LED manufacturer's data and engineering design estimates, based on IESNA LM-80 methodology. Actual experience may vary due to field application conditions. L70 is the predicted time when LED performance depreciates to 70% of initial lumen output. Calculated per IESNA TM21-11. Published L70 hours limited to 6 times actual LED test hours

Ambient Temp°C	Lumen Package	Calculated L70 Hours	L70 per TM-21	Lumen Maintenance % at 60,000 hrs
25°C	A06-A07	>77,000 hours	>77,000 hours	90%
25°C	All others	>100,000 hours	>100,000 hours	96%

Dimensions

Standard Drill Pattern

Drill Template #5

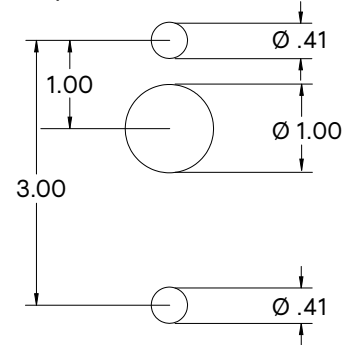

Standard Arm Mounting Hole Pattern

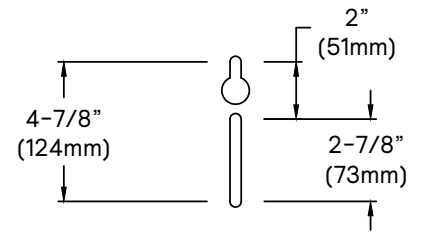

OPF-S OptiForm small

Site & area luminaire

Dimensions

OptiForm Standard Arm

Weight: 11 lb (5.0 kg)

EPA: 0.2 ft² (0.018 m²)

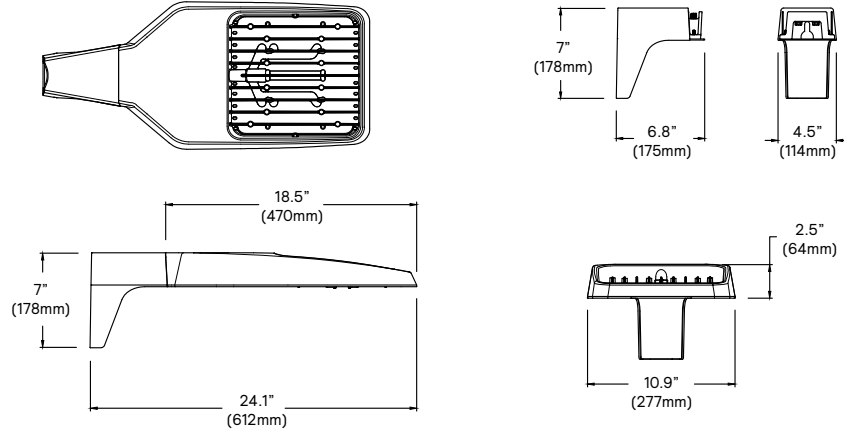

OptiForm External Housing Shield

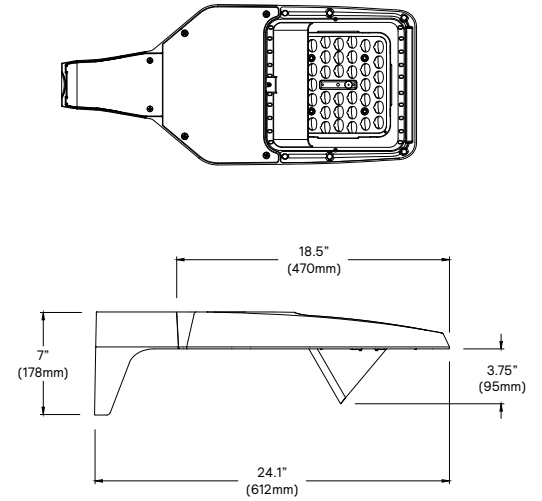

OptiForm Mast Arm

Weight: 12.6 lb (5.7 kg)

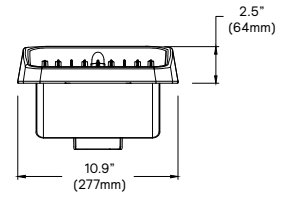
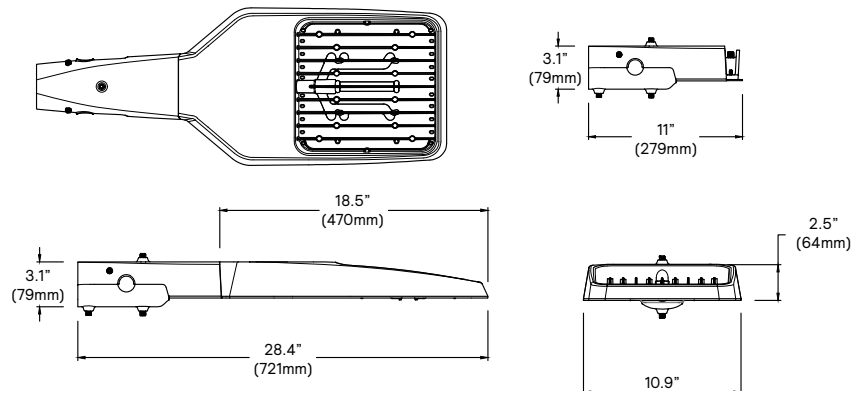

OptiForm Wall Mount

Weight: 11.5 lb (5.2 kg)

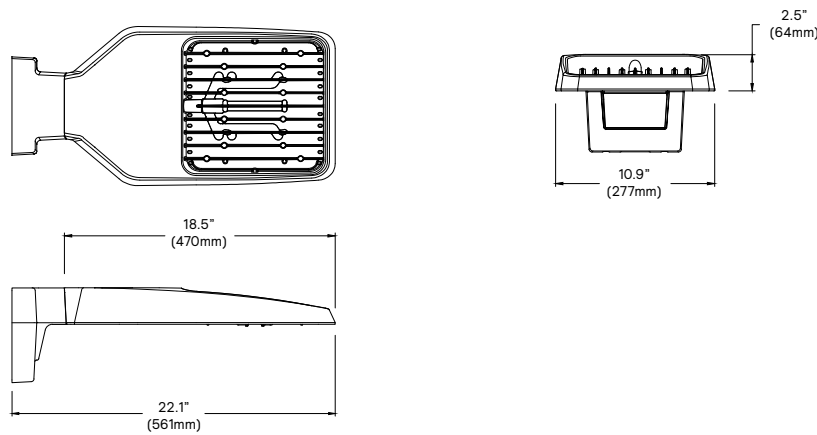

OPF-S OptiForm small

Site & area luminaire

Specifications

Housing

Housing and door constructed of low copper die cast Aluminum alloy (A360) with detachable arms for quick mounting. Heatsink is integral to the housing providing passive cooling of LEDs to maintain long LED life. Luminaire housing rated to IP65, LED Modules rated IP66 tested in accordance to Section 9 of IEC 60598-1. OptiForm carries and impact rating of IK08.

Vibration resistance

OptiForm is tested and rated to standards set forth in ANSI C136.31-2018 Level 2 for Bridge and Overpass applications.

Light engine

Light engine comprises of a module of 40-LED aluminum metal clad board fully sealed with optics: Medium = 2 Modules with 80 LEDs, Large = 4 modules with 160 LEDs. Module is RoHS compliant. Color temperature as per ANSI/NEMA bin 2700 Kelvin nominal (2725 ±145K), 3000 Kelvin nominal (3045K +/- 175K) or 4000 Kelvin nominal (3985K +/- 275K), CRI 70 Min. 75 Typical. Other CCT/CRI also available, consult factory. LED light engine is rated IP66 in accordance to Section 9 of IEC 60598-1.

Energy saving benefits

System efficacy up to 182 lms/W with significant energy savings over Pulse Start Metal Halide luminaires. Optional control options provide added energy savings during unoccupied periods.

Optical systems

Site and Area optical distributions include Types 2 Medium, 3 Medium, 4 Medium, 4 Wide, 5 Narrow, 5 Medium, 5 Wide, and Auto Front Row. LEED Corner Left, LEED Corner Right, and Backlight Control distributions also available to provide excellent cutoff to meet the most stringent requirements at property lines. Optional internal shields mount to LED optics and are available with Type 2M, 3M, and 4M distributions. Types 2M and 3M can be rotated at 90° or 270° when specified, and are factory set only. Site and Area optics shall be performance tested per LM-79 and TM-15 (IESNA) certifying their photometric performance. Luminaire designed with 0% uplight (U0 per IESNA TM-15).

Precision Plus optical distributions include Types 2, 3, 4 and 5 and are designed to illuminate pedestrian scale applications by providing lower glare, while still achieving desired distribution, optimized spacing, and excellent uniformity. Optics are made of optical grade polymer refractor lenses and shall be performance tested per LM-63, LM-79 and TM-15 (IESNA) certifying their photometric performance. Luminaire designed with 0% uplight (U0 per IESNA TM-15).

Mounting

Standard luminaire arm mounts to square poles with knock-out on the arm to allow for mounting to 4" O.D. round poles. Standard arm casting can accommodate existing bolt spacing from 2" to 4-7/8". It is recommended to use the bolster plate kit OPF RMB when it's not a new installation or if the mounting holes are larger than 0.41" (10mm).

OptiForm features a Mast Arm for Mounting to 2-3/8x4" tenon as well as wall mount casting for exterior building mount applications.

Control options

Dimming Leads Externally Accessible (DLEA): Access to 0-10V dimming leads supplied through back of luminaire (for secondary dimming controls by others). Cannot be used with other control options.

Sensor Ready Zhaga Socket Connector (SRDR): Product is D4i Certified and equipped with Sensor Ready drivers connected to 4-pin Zhaga Book 18 compliant receptacle designed for sensor and other control system applications. Receptacle is rated IP66 assembly in a compact design that provides a sealed electrical interface and rated UV resistance, mounted on underside of the luminaire, protective dust cap included. When a controller not provided by Signify is used with Sensor Ready Zhaga socket connector, the controller must be certified to work with the Xitanium SR LED drivers as part of the SR certified program. SRDR can be used with NEMA 7-pin twist lock receptacle, which is mounted on top of the luminaire.

Automatic Profile Dimming (CS/CM/CE/CA): Standard dimming profiles provide flexibility towards energy savings goals while optimizing light levels during specific dark hours. Dimming profiles include two dimming settings including dim to 30% or 50% of the total lumen output. When used in combination with not programmed motion response it overrides the controller's schedule when motion is detected. After 5 minutes with no motion, it will return to the automatic dimming profile schedule. Automatic dimming profile scheduled with the following settings:

- **CS50/CS30:** Security for 7 hours night duration (Ex., 11 PM – 6 AM)
- **CM50/CM30:** Median for 8 hours night duration (Ex., 10 PM – 6 AM)

All above profiles are calculated from mid point of the night. Dimming is set for 6 hours after the mid point and 1 or 2 hours before depending of the duration of dimming. Cannot be used with other dimming control options

Field Adjustable Wattage Selector (FAWS): Luminaire equipped with the ability to manually adjust the wattage in the field to reduce total luminaire lumen output and light levels. Comes pre-set to the highest position lumen output selected. Use chart below to estimate reduction in lumen output desired. Cannot be used with other control options or motion response.

FAWS Position	Percent of Typical Lumen Output	FAWS Position	Percent of Typical Lumen Output
1	25%	6	80%
2	50%	7	85%
3	55%	8	90%
4	65%	9	95%
5	75%	10	100%

Note: Typical value accuracy +/- 5%

Motion response options

Bi-Level Infrared Motion Response (BL50): Motion Response module is mounted integral to luminaire factory pre-programmed to 50% dimming when not ordered with other control options. BL-IMRI is set/operates in the following fashion: The motion sensor is set to a constant 50%. When motion is detected by the PIR sensor, the luminaire returns to full power/light output. Dimming on low is factory set to 50% with 5 minutes default in "full power" prior to dimming back to low. When no motion is detected for 5 minutes, the motion response system reduces the wattage by 50%, to 50% of the normal constant wattage reducing the light level. Other dimming settings can be provided if different dimming levels are required (contact Technical Support for details).

Infrared Motion Response with Other Controls: When used in combination with other controls (Automatic Dimming Profile), motion response device will simply override controller's schedule with the added benefits of a combined dimming profile and sensor detection. In this configuration, the motion response device cannot be re-programmed with FSIR-100 Wireless Remote Programming Tool. The profile can only be re-programmed via the controller.

Infrared Motion Response Lenses (L2): Infrared Motion Response Integral module is available with two different sensor lens types to accommodate various mounting heights and occupancy detection ranges. Lens #2 is designed for mounting heights 8' to 15'. Lens #3 is designed for higher mounting heights up to 20' with a 40' diameter coverage area. See charts for approximate detection patterns:

Luminaire with #2 lens

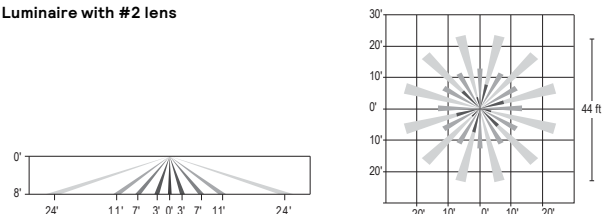

OPF-S OptiForm small

Site & area luminaire

Specifications (cont'd)

Electrical

Twist-Lock Receptacle (TR5/TR7): Twist Lock Receptacle with 5 pins enabling dimming or with 7 pins with additional functionality (by others) can be used with a twistlock photoelectric cell or a shorting cap. Dimming Receptacle Type B (5-pin) and Type D-24 (7-pin) in accordance to ANSI C136.41. Can be used with third-party control system. Receptacle located on top of luminaire housing. When specifying receptacle with twistlock photoelectric cell, voltage must be specified. When ordering 7-pin Twist-lock receptacle (TR7), all 7 pins are wired to respective pins with the Sensor Ready (SR) driver, and photocell or shorting cap is not included. When ordering a twist-lock receptacle with a photocell (TLP), the receptacle used is a 7-pin receptacle, with pins 6 and 7 connected to SR DALI driver. 0-10V dimming leads (pins 4 and 5) are connected if not ordered with any other dimming option.

Driver: Driver efficiency (>90% standard). 120-480V available (restrictions apply). Open/short circuit protection. All drivers are 0-10V dimming to 10% power standard, except when using Sensor Ready (SR) drivers, which uses DALI protocol (options CS50/CM50/CS30/CM30, SRDR, and TR7). Drivers are RoHS and FCC Title 47 CFR Part 15 compliant.

Button Photocontrol (PCB): Button style design for internal luminaires mounting applications. The photocontrol is constructed of a high impact UV stabilized polycarbonate housing. Rated voltage of 120V or 208-277V with a load rating of 1000 VA. The photocell will turn on with 1-4Fc of ambient light.

Surge protection (SP1/SP2): Surge protection device tested in accordance with ANSI/IEEE C62.45 per ANSI/IEEE C62.41.2 Scenario I Category C High Exposure 10kV/10kA waveforms for Line-Ground, Line-Neutral and Neutral-Ground, and in accordance with DOE MSSLC Model Specification for LED Roadway Luminaires Appendix D Electrical Immunity High test level 10kV/10kA. 20kV / 10kA surge protection device that provides extra protection beyond the SP1 10kV/10kA level.

Listings

UL/cUL wet location listed to the UL 1598 standard, suitable for use in ambient temperatures from -40° to 40°C (-40° to 104°F). All Optiform configurations are qualified under Design Lights Consortium Premium classification. Consult DLC Qualified Products list to confirm your specific luminaire selection is approved. CCTs 3000K and warmer are Dark Sky Approved.

Finish

Each standard color luminaire receives a fade and abrasion resistant, electrostatically applied, thermally cured, triglycidal isocyanurate (TGIC) textured polyester powdercoat finish. Standard colors include bronze (BZ), black (BK), white (WH), dark gray (DGY), and medium gray (MGY). Consult Factory for specs on optional, custom colors, and marine grade paint.

Service Tag

Each individual luminaire is uniquely identifiable, thanks to the Service tag application. With a simple scan of a QR code, placed on the inside of the mast door, you gain instant access to the luminaire configuration, making installation and maintenance operations faster and easier, no matter what stage of the luminaire's lifetime. Just download the APP and register your product right away. For more details visit: [signify.com](https://www.signify.com)

Warranty

OptiForm luminaires feature a 5-year limited warranty
See [signify.com/warranties](https://www.signify.com/warranties) for complete details and exclusions.