



Jump's contemporary aesthetic combines the latest lighting technologies with texture, pattern, and rhythm along an uninterrupted end to end continuum of luminance.

Jump includes AccuRender technology for the highest color quality at the highest efficacy.

Project: _____
 Location: _____
 Cat.No: _____
 Type: _____
 Line ID: _____ Qty: _____
 Notes: _____

Ordering guide

example: 1228LBGQE087DEW

Family	Source	CRI/CCT ¹	Lumens ¹	Optics	Housing	Run Length	Wiring ²	Voltage	Driver	Finish
1228	L			Q					E	
1228 Jump Wall Asymmetric	L LED	A CRI 90, 4000K B CRI 90, 3500K C CRI 90, 3000K	C 4200 lm/4ft E 3100 lm/4ft G 2000 lm/4ft	Q Ribbed MesoOptics Lens	E SolidSide P PixelPerf S SplashPerf	04 4ft 08 8ft xx Continuous Run (4ft increments)	7 1cct Dimming E 2cct A/B Dimming (Alt. 4ft sections) M 1cct Dimming + EM Wiring N 1cct Dimming + EM Batt. Pack	D UNV 120-277V 3 347V	E Advance 0-10V (1% Dim)	W Standard White T Titanium Silver B Black C Custom

1. Nominal values within a range. Consult photometry data for CRI, color temp, lumens & distribution of chosen configuration.
 2. Not all wiring types are available with all configurations. Consult Ledalite for a complete list of available options.

Jump linear wall

Cross Section View

Asymmetric

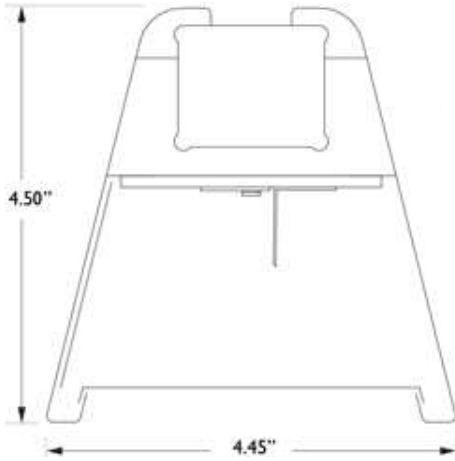

Cross Section View – Endcaps

S – Luminous Sculpted (standard)

F – Flat

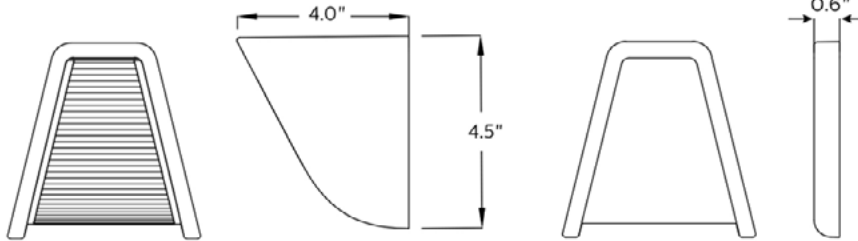

Cross Section View – With Wall Mount

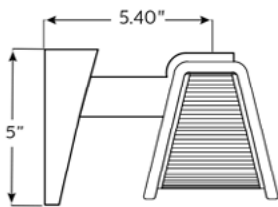

Jump linear wall

Specifications

Optical System

White light emitted from a linear array of downward facing LEDs is laterally redirected using either a biconvex lens or optical microstructures embedded in a layer of MesoOptics DX film. An extruded, ribbed acrylic lens and MesoOptics film assembly then generates an optimal batwing distribution and a uniform continuum of light.

Endcaps

Diecast aluminum, available in luminous sculpted (standard) or flat (optional).

Finish

High quality powder coated, available in matte white, black or titanium silver. Other custom colors available on request.

Housing

20 gauge cold-rolled steel, precision formed and welded with optional perforated patterns.

Weight

Maximum 3.5lb/ft.

Electrical

Factory pre-wired to section ends with quick-wire connectors.

Standard Driver

Advance Xitanium 0-10V, 1-100%. Class 2 rated output. Consult Ledalite for other available drivers.

Standard Battery Pack

Bodine, 90 min, 10W, Class 2 rated output, Emergency lumen output = 10W x luminaire efficacy x 1.1. Typical output: symmetric 1300lm, asymmetric 1100lm.

Lumen Maintenance

At an ambient temperature of 25°C, the LED lumen maintenance expectation according to IES TM-21-21 is:
L₈₀ (10k) >60,000 hrs (Reported methodology).

Source Color

LEDs rated for color rendering CRI >90, R9 >50 and fixture to fixture color accuracy within 2 SDCM.

Mounting

Variable position mounts can be installed up to 18" from each joint and end (suspended, surface, wall or cantilever). In the suspended mount, high strength aircraft cable and stainless steel gripper provide unlimited vertical adjustment and are independently tested to stringent safety standards.

Joints

Self-aligning joining system with hands-free pre-joining wire access.

Approvals

Certified to UL, CSA and IES standards.

Warranty

Signify indoor professional luminaires 5 year LED warranty: www.signify.com/warranties.

Environment

Rated for dry or damp locations in operating ambient temperatures 0-40°C (32-104°F). Certain luminaire components may be adversely affected by contaminants. Damage caused by sulfur, chlorine, petroleum based solutions or other contaminants in the area of operation are not covered under warranty. Not suitable for natatorium environments.

Due to continuing product improvements, Ledalite reserves the right to change the specifications without notice.

Jump linear wall

Photometrics**

MesoOptics + SolidSide Housing (QE) – Asymmetric Distribution

Spacing Criteria: 1.65/1.30

(Click "PDF" and "IES" text to Download)

Lumen Package	Nominal CRI & CCT	Flux (lm)	Watts (W)	Efficacy (LPW)	CRI	R9	RP-1 VDT	Photometry Report	IES File
4200 lm/4ft	CRI 90, 4000K	4247	45.8	92.7	90+	50+	N/A	PDF	IES
	CRI 90, 3500K	4186	45.4	92.2	90+	50+	N/A	PDF	IES
	CRI 90, 3000K	3991	45.6	87.5	90+	50+	N/A	PDF	IES
3100 lm/4ft	CRI 90, 4000K	3176	33.0	96.2	90+	50+	Normal spaces	PDF	IES
	CRI 90, 3500K	3131	32.6	96.0	90+	50+	Normal spaces	PDF	IES
	CRI 90, 3000K	2985	32.8	91.0	90+	50+	Normal spaces	PDF	IES
2000 lm/4ft	CRI 90, 4000K	2013	19.8	101.7	90+	50+	Normal spaces	PDF	IES
	CRI 90, 3500K	1984	19.6	101.2	90+	50+	Normal spaces	PDF	IES
	CRI 90, 3000K	1892	19.7	96.0	90+	50+	Critical spaces	PDF	IES

**Photometry is measured to IES standards using CRI 80 LEDs. New AccuRender high efficacy CRI 90 LEDs will meet or exceed posted energy specifications including wattage, lumen output, and efficacy.

CANDELA DISTRIBUTION						Flux
	0	22.5	45	67.5	90	Lumens
0	724	724	724	724	724	
5	783	768	707	698	693	71
15	1025	903	686	677	703	224
25	1184	1018	650	675	699	376
35	966	889	597	599	577	442
45	572	564	460	422	375	370
55	315	308	286	257	226	252
65	172	163	155	146	129	153
75	81	74	69	70	62	76
85	9	13	18	21	16	20
90	0	0	0	0	0	
95	0	0	0	0	0	0
105	0	0	0	0	0	0
115	0	0	0	0	0	0
125	0	0	0	0	0	0
135	0	0	0	0	0	0
145	0	0	0	0	0	0
155	0	0	0	0	0	0
165	0	0	0	0	0	0
175	0	0	0	0	0	0
180	0	0	0	0	0	

*Photometric data shown is for 2000 lm/4ft, 3500K, 90 CRI configuration.

COEFFICIENTS OF UTILIZATION (%)													
Pc---	80				70				50				0
Pw---	70	50	30	10	70	50	30	50	30	10	0	0	
RCR													
0	119	119	119	119	116	116	116	111	111	111	100		
1	110	106	102	99	108	104	100	100	97	94	87		
2	101	94	88	83	99	92	87	89	84	80	75		
3	93	84	77	71	91	82	76	79	74	69	65		
4	86	75	67	61	84	74	66	71	65	60	56		
5	80	68	60	53	78	67	59	65	58	53	49		
6	74	61	53	47	72	61	53	59	52	47	44		
7	69	56	48	42	67	55	47	54	47	42	39		
8	64	51	43	38	63	51	43	49	42	37	35		
9	60	47	39	34	59	47	39	45	39	34	32		
10	56	44	36	31	55	43	36	42	35	31	29		

ZONAL LUMEN SUMMARY			
Zone	Lumens	%Fixture	%Lamp
0-30	671	33.8%	33.8%
0-40	1112	56.1%	56.1%
0-60	1735	87.4%	87.4%
0-90	1984	100.0%	100.0%
90-130	0	0.0%	0.0%
90-150	0	0.0%	0.0%
90-180	0	0.0%	0.0%
0-180	1984	100.0%	100.0%

Electrical				
120V: P(W), I(A), THD(%), PF	19.6	0.164	8.1	0.994
277V: P(W), I(A), THD(%), PF	19.6	0.073	11.7	0.965
347V: P(W), I(A), THD(%), PF	N/A	N/A	N/A	N/A

AVG LUMINANCE (cd/m²)			
	0	45	90
0	6054	6054	6054
5	6579	5932	5817
15	8879	5938	6092
25	10930	5998	6453
35	9861	6099	5889
45	6766	5442	4432
55	4589	4175	3295
65	3411	3060	2550
75	2631	2244	2010
85	826	1701	1510

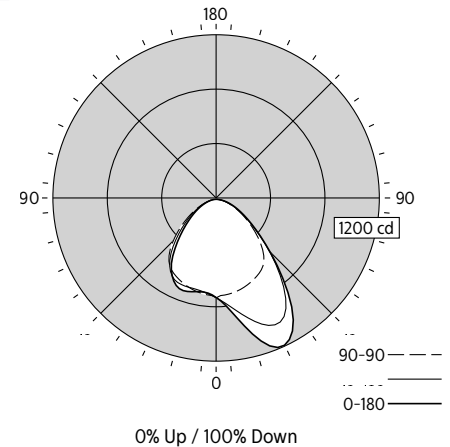

Jump linear wall

Photometrics**

MesoOptics + SplashPerf or PixelPerf Housing (QP or QS) – A symmetric Distribution

Spacing Criteria: 1.69/1.31

(Click "PDF" and "IES" text to Download)

Lumen Package	Nominal CRI & CCT	Flux (lm)	Watts (W)	Efficacy (LPW)	CRI	R9	RP-1 VDT	Photometry Report	IES File
4200 lm/4ft	CRI 90, 4000K	4266	45.8	93.1	90+	50+	N/A	PDF	IES
	CRI 90, 3500K	4205	45.4	92.6	90+	50+	N/A	PDF	IES
	CRI 90, 3000K	4010	45.6	87.9	90+	50+	N/A	PDF	IES
3100 lm/4ft	CRI 90, 4000K	3191	33.0	96.7	90+	50+	Normal spaces	PDF	IES
	CRI 90, 3500K	3145	32.6	96.5	90+	50+	Normal spaces	PDF	IES
	CRI 90, 3000K	2999	32.8	91.4	90+	50+	Normal spaces	PDF	IES
2000 lm/4ft	CRI 90, 4000K	2022	19.8	102.1	90+	50+	Normal spaces	PDF	IES
	CRI 90, 3500K	1993	19.6	101.7	90+	50+	Normal spaces	PDF	IES
	CRI 90, 3000K	1900	19.7	96.4	90+	50+	Normal spaces	PDF	IES

**Photometry is measured to IES standards using CRI 80 LEDs. New AccuRender high efficacy CRI 90 LEDs will meet or exceed posted energy specifications including wattage, lumen output, and efficacy.

CANDELA DISTRIBUTION						Flux
	0	22.5	45	67.5	90	Lumens
0	665	665	665	665	665	
5	710	697	650	647	646	65
15	919	813	633	639	669	206
25	1111	938	604	645	666	353
35	943	850	558	571	551	421
45	579	549	433	402	350	357
55	325	306	270	237	206	244
65	180	165	150	133	129	150
75	88	77	66	74	64	77
85	18	18	15	26	27	25
90	10	8	3	15	17	
95	13	10	3	15	20	13
105	17	14	3	18	23	15
115	19	17	3	20	25	17
125	22	21	4	23	26	16
135	25	20	5	23	27	14
145	23	17	5	19	24	10
155	18	14	6	15	18	6
165	12	9	6	11	12	3
175	7	7	6	7	8	1
180	7	7	7	7	7	

*Photometric data shown is for 2000 lm/4ft, 3500K, 90 CRI configuration.

COEFFICIENTS OF UTILIZATION (%)													
Pc---	80				70				50				0
Pw---	70	50	30	10	70	50	30	50	30	10	0	0	
RCR													
0	118	118	118	118	115	115	115	108	108	108	95		
1	109	105	101	97	106	102	99	97	94	92	82		
2	100	93	87	81	97	90	85	86	82	78	71		
3	92	82	75	69	89	81	74	77	71	66	61		
4	85	74	66	60	82	72	65	69	63	58	53		
5	78	66	58	52	76	65	57	62	56	50	46		
6	73	60	52	46	70	59	51	57	50	45	41		
7	67	55	46	41	65	54	46	52	45	40	37		
8	63	50	42	36	61	49	41	47	41	36	33		
9	59	46	38	33	57	45	38	44	37	32	30		
10	55	42	35	30	54	42	34	40	34	29	27		

ZONAL LUMEN SUMMARY			
Zone	Lumens	%Fixture	%Lamp
0-30	624	31.3%	31.3%
0-40	1045	52.4%	52.4%
0-60	1645	82.5%	82.5%
0-90	1898	95.2%	95.2%
90-130	61	3.0%	3.0%
90-150	85	4.3%	4.3%
90-180	95	4.8%	4.8%
0-180	1993	100.0%	100.0%

Electrical				
120V: P(W), I(A), THD(%), PF	19.6	0.164	8.1	0.994
277V: P(W), I(A), THD(%), PF	19.6	0.073	11.7	0.965
347V: P(W), I(A), THD(%), PF	N/A	N/A	N/A	N/A

AVG LUMINANCE (cd/m²)			
	0	45	90
0	5559	5559	5559
5	5709	5441	5199
15	7020	5424	5112
25	8313	5472	4988
35	7133	5540	4169
45	4566	4927	2764
55	2763	3724	1749
65	1717	2734	1233
75	989	1865	724
85	258	1017	391

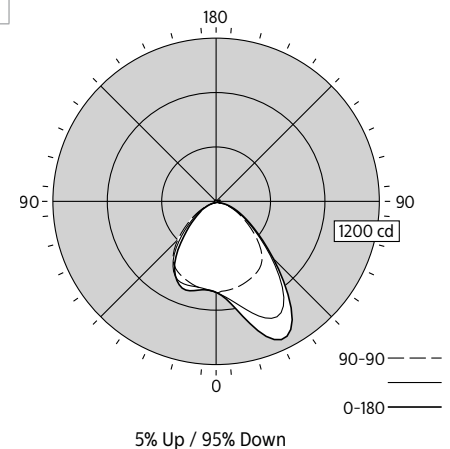

© 2023 Signify Holding. All rights reserved. The information provided herein is subject to change, without notice. Signify does not give any representation or warranty as to the accuracy or completeness of the information included herein and shall not be liable for any action in reliance thereon. The information presented in this document is not intended as any commercial offer and does not form part of any quotation or contract, unless otherwise agreed by Signify.

Signify North America Corporation
400 Crossing Blvd, Suite 600
Bridgewater, NJ 08807
Telephone 855-486-2216

Signify Canada Ltd.
281 Hillmount Road,
Markham, ON, Canada L6C 2S3
Telephone 800-668-9008

All trademarks are owned by Signify Holding or their respective owners.