

# INSTALLATION

# CHLORIDE

by  Signify

## WARNINGS AND INSTRUCTIONS FOR LUMINAIRES

**IMPORTANT:** FOR YOUR PROTECTION, YOU MUST CAREFULLY READ ALL WARNINGS AND INSTRUCTIONS IN THEIR ENTIRETY PRIOR TO INSTALLATION, OPERATION, SERVICE, OR MAINTENANCE. FAILURE TO DO SO CAN RESULT IN DEATH, PERSONAL INJURY AND PROPERTY DAMAGE. If you do not understand these warnings and instructions, or if additional information is desired, please contact the Customer Care Call Center at 800-555-0050.

- **Installation, service, and maintenance of luminaires must be performed by a qualified professional and in accordance with all federal, state, and local laws, regulations, and electrical codes. This professional should be familiar with the construction and operation of this product and any hazards involved. If not qualified, do not attempt installation, service or maintenance.**
- **To reduce the risk of death, personal injury or property damage from fire, electric shock, falling parts, cuts, abrasions, and other hazards, please read all warnings and instructions included with the luminaire, on the luminaire's packaging and affixed to the luminaire itself.**
- **Maintenance of the luminaires should be performed by person(s) familiar with the luminaire's construction and operation and any hazards involved.**



### WARNING

#### RISK OF FIRE, ELECTRIC SHOCK OR PERSONAL INJURY

- Disconnect or turn off power before attempting any installation, service or maintenance.
- Verify that supply voltage is correct by referencing the luminaire label information.
- Make all electrical and ground connections in accordance with the National Electrical Code (NEC) and any other applicable laws, regulations, or codes.
- All wiring connections should be capped with UL-approved wire connectors.



### WARNING

#### RISK OF PERSONAL INJURY

- Wear gloves and safety glasses at all times when removing luminaire from carton, installing, servicing or performing maintenance.
- Avoid direct eye exposure to the light source while it is on.



### WARNING

#### RISK OF PERSONAL INJURY

- Keep combustible materials away from LED/lamp & lens.
- Do not operate in close proximity to persons, combustible materials or substances affected by heat or drying.



### WARNING

#### RISK OF FIRE, ELECTRIC SHOCK OR PERSONAL INJURY

- Allow LED/lamp & lens to cool before handling.
- Do not touch enclosure or light source.
- Do not exceed maximum wattage marked on luminaire label.
- Follow all manufacturer's warnings, recommendations, instructions, and restrictions for driver type, burning position, mounting locations and replacement.



### CAUTION

#### RISK OF PRODUCT DAMAGE

- Never connect luminaires and/or components under load with supply voltage turned on.
- Do not mount or support these luminaires in a manner that can cut the outer jacket or damage wire insulation.
- Do not restrict fixture ventilation. Allow for some volume of airspace around the luminaire. Avoid covering the luminaire with insulation, foam, or other material that will prevent convection or conduction cooling.
- Do not exceed luminaire maximum ambient temperature.
- Do not modify the luminaire.
- Only use luminaire in its intended application and location.
- LED products are polarity sensitive. Ensure proper polarity before installation.
- Electrostatic Discharge (ESD) can damage LED. Personal grounding equipment must be worn during all installation and servicing of the luminaire.
- Do not touch individual electrical components as this can cause ESD, shorten LED life, or impact LED performance. Some components inside the luminaire may not be serviceable. In the unlikely event, your luminaire may require service, stop using it immediately and contact the Customer Care Call Center at 800-555-0050.
- Always read the luminaire's complete installation instructions prior to installation for any additional luminaire- specific warnings.
- In the case of HID or Fluorescent luminaires, regular re-lamping is required to keep the luminaire operating within safe limits.

- **Do not install damaged products.** Handling and installing damaged products can potentially increase the risks mentioned. In case of damage and/or missing parts upon arrival of the luminaire, please contact the Customer Care Call Center at 800-555-0050.
- These instructions do not purport to cover all details or variations in equipment nor to provide every possible contingency to meet in connection with installation, operation, or maintenance. Should further information be desired, or should particular problems arise which are not covered sufficiently for the purchaser's or owner's purposes, this matter should be referred to the Customer Care Call Center at 800-555-0050.
- Please see luminaire-specific Installation and Maintenance Instruction for additional warnings or any applicable FCC or regulatory statements. Failure to follow any of these instructions could void luminaire warranties.

#### **Luminaire Maintenance**

- Regular luminaire maintenance programs are recommended.
- It is recommended to clean the outside of the luminaire and the refractor/lens.
- Frequency of cleaning will depend on ambient dirt level and minimum light output which is acceptable to the user.
- If clean water is not sufficient for cleaning, use a neutral, synthetic, non-scratching, and non-abrasive cleaning substance.
- Never use alkaline and/or acetous cleaning substances.
- Make sure that the cleaning substance is carefully removed by rinsing with lots of clean water.
- Signify recommends using a cleaning solution that has a PH between 5 and 8.
- Recycle: For information on how to recycle electronic products and components, please visit [www.epa.gov](http://www.epa.gov).

NOTE: This equipment has been tested and found to comply with the limits for a Class A digital device, pursuant to part 15 of the FCC Rules. These limits are designed to provide reasonable protection against harmful interference when the equipment is operated in a commercial environment. This equipment generates, uses, and can radiate radio frequency energy and, if not installed and used in accordance with the instruction manual, may cause harmful interference to radio communications. Operation of this equipment in a residential area likely to cause harmful interference in which case the user will be required to correct the interference at his own expense.

# INSTALLATION INSTRUCTIONS

## LED INDUSTRIAL NEMA4X & NSF RATED EXIT/EMERGENCY COMBO

---

### IMPORTANT SAFEGUARDS

When using electrical equipment, basic safety precautions should always be followed, including the following.

#### READ AND FOLLOW ALL SAFETY INSTRUCTIONS

1. Do not let power supply cords touch hot surfaces.
2. Do not mount near gas or electric heaters.
3. Turn off electrical power before and during installation.
4. Turn off electrical power before opening the unit for maintenance or servicing.
5. Use caution when handling batteries. Battery acid can cause burns to the skin and eyes. Avoid possible shorting.
6. Equipment should be mounted in locations and at heights where it will not readily be subject to tampering by unauthorized personnel.
7. The use of accessory equipment not authorized by the manufacturer may cause an unsafe condition.
8. Do not use this equipment for other than its intended purpose.
9. Servicing of this equipment should only be performed by qualified service personnel.

**Note:** UL recommended maximum mounting height for this model is 18-ft

#### WALL MOUNT INSTALLATION

1. Extend AC of rated voltage nearby to the unit into recessed junction box (supplied by others). This circuit should NOT be energized/live at this time.
2. Remove the six screw caps and the six mounting lens screws until the EXIT lens is detachable.
3. Separate the lens and EXIT panel assembly (three pieces) from the housing (Figure 1).
4. Determine the appropriate knockouts (K/O) to remove for mounting to the junction box. Support area around the knockouts and remove them using a hammer and screwdriver. Remove one of the  $\frac{3}{4}$ " knockouts in the center and route the fixture supply wires through it.
5. Place the gasket, provided, between the fixture's backplate and the junction box. Route the fixture supply wires through one of the circular holes in the center of the gasket.
6. Refer to the "Wiring Diagrams" section and make electrical connections inside the junction box using the wire nuts provided. Cap off the unused (Red or Black) lead. Complete battery connection.
7. Using the two screws provided and the previously removed K/O holes, mount the fixture to the surface over the recessed junction box. Tighten the screws enough to compress the gasket to ensure a good, sealed joint.
8. Remove one or both directional indicators from the EXIT panel, as needed.
9. Reinstall the lens and EXIT panel assembly using the stainless screws kit (six plastic caps, six screws and twelve O-rings). Tighten the screws enough (7.5 lbf-in torque is recommended) to compress the O-rings to ensure a good, sealed joint. Be careful not to overtighten, as that could damage the front lens.
10. Apply power. Allow the unit to charge for 24 hours before testing it in emergency mode.

#### CEILING OR END-MOUNT INSTALLATION

1. Extend AC of rated voltage nearby to the unit into recessed junction box (supplied by others). This circuit should NOT be energized/live at this time.
2. Remove the six screw caps and the six mounting lens screws until the EXIT lens is detachable.
3. Separate the lens and EXIT panel assembly (three pieces) from the housing. Detach the interior frame by removing the (4) frame mounting screws (Figure 2).

## CEILING OR END-MOUNT INSTALLATION (Contd.)

4. Remove the knockouts in the top or lateral side of the housing using a hammer and screwdriver. Detach the small gasket from the sheet and place it between the housing and the mounting canopy. Secure the canopy to the fixture housing using the nipple assembly and lock nuts.
5. Route the fixture supply wires through the gasket, canopy and spider plate. Refer to the “Wiring Diagrams” section and make electrical connections inside the junction box using the wire nuts provided. Cap off the unused (Red or Black) lead. Complete battery connection.
6. Place the square gasket piece provided between the spider plate and the junction box. Secure the spider plate to the junction box using the mounting screws provided. Tighten the screws enough to compress the gasket to ensure a good, sealed joint.
7. Attach the canopy to the spider plate using the (4) screws and rubber O-rings. Tighten the screws enough to ensure a good, sealed joint.
8. Remove one or both directional indicators from the EXIT panels, as needed. Install the lens and EXIT panel assembly using the stainless screws kit (six plastic caps, six screws and twelve O-rings). Tighten the screws enough (7.5 lbf-in torque is recommended) to compress the O-rings to ensure a good, sealed joint. Be careful to not overtighten, as that could damage the front lens
9. Apply power. Allow the unit to charge for 24 hours before testing it in emergency mode.

## INSTALLATION WITH MOUNTING BRACKETS

1. Extend AC of rated voltage nearby to the unit into recessed junction box (supplied by others). This circuit should NOT be energized/live at this time.
2. Remove the (2) side gaskets from the gasket sheet provided and attach the sheet to the fixture backplate.
3. Mount the (2) surface mounting brackets provided onto the backplate and secure using the screws provided.
4. Place the housing on the required surface. Drill (4) holes using the brackets holes as a drilling template and fix the mounting anchors inside the holes.
5. Remove the six screw caps and the six mounting lens screws until the EXIT lens is detachable.
6. Separate the lens and EXIT panel assembly (three pieces) from the housing (Figure 1).
7. Remove the appropriate knockout (K/O) on the backplate using a hammer and screwdriver. Route the fixture supply wires through the opening on the backplate, and the gasket attached to it.
8. Refer to the “Wiring Diagrams” section and make electrical connections inside the junction box using the wire nuts provided. Cap off the unused (Red or Black) lead. Complete battery connection.
9. Remove one or both directional indicators from the EXIT panel, as needed.
10. Reinstall the lens and EXIT panel assembly using the stainless screws kit (six plastic caps, six screws and twelve O-rings). Tighten the screws enough (7.5 lbf-in torque is recommended) to compress the O-rings to ensure a good, sealed joint. Be careful not to overtighten, as that could damage the front lens.
11. Mount the fixture to the surface using the (4) mounting screws and previously installed screw anchors.
12. Apply power. For units with battery, allow the unit to charge for 24 hours before testing it in emergency mode.

## LED STATUS INDICATOR KEY and TROUBLESHOOTING

LED status	Indication	Action to take
Red	<ol style="list-style-type: none"> <li>1. Battery connection is not made</li> <li>2. Battery has been diagnosed as dead or defective after 24 hours of continuous charging with AC power supplied</li> </ol>	<ol style="list-style-type: none"> <li>1. Make connection; or if battery is connected, disconnect battery for eight seconds and then reconnect.</li> <li>2. Replace the battery.</li> </ol>
Green	Battery is connected, AC power has been supplied and fixture is in charging state.	This is the normal state. No action required.
Unlit	AC power has not been supplied or unit is in EM mode	Supply AC power or wait until utility power is restored

## MAINTENANCE

**Caution:** Always turn off AC power to the equipment before servicing. Servicing should be performed only by a qualified service technician. Use only MANUFACTURER supplied replacement parts.

**BATTERY:** The battery supplied requires no maintenance. However, it should be tested periodically and replaced when it no longer operates the connected unit for the duration of a 30-second or 90-minute test.

## OPERATION & TESTING

National Electric Code (NEC) and NFPA 101 current Life Safety code requirements require that routine tests need to be performed as listed below: Once every month, the unit needs to be tested for duration of 30 seconds. Place and hold the magnet near the magnetic switch on the fixture to perform this test. Once every 12 months, a full 90-minute (per UL requirements) test needs to be performed on the unit. Disconnect power to the unit and leave it in emergency mode. The lamps should stay ON for at least 90 minutes. Written records of the testing are to be kept for examination by the authority having jurisdiction.

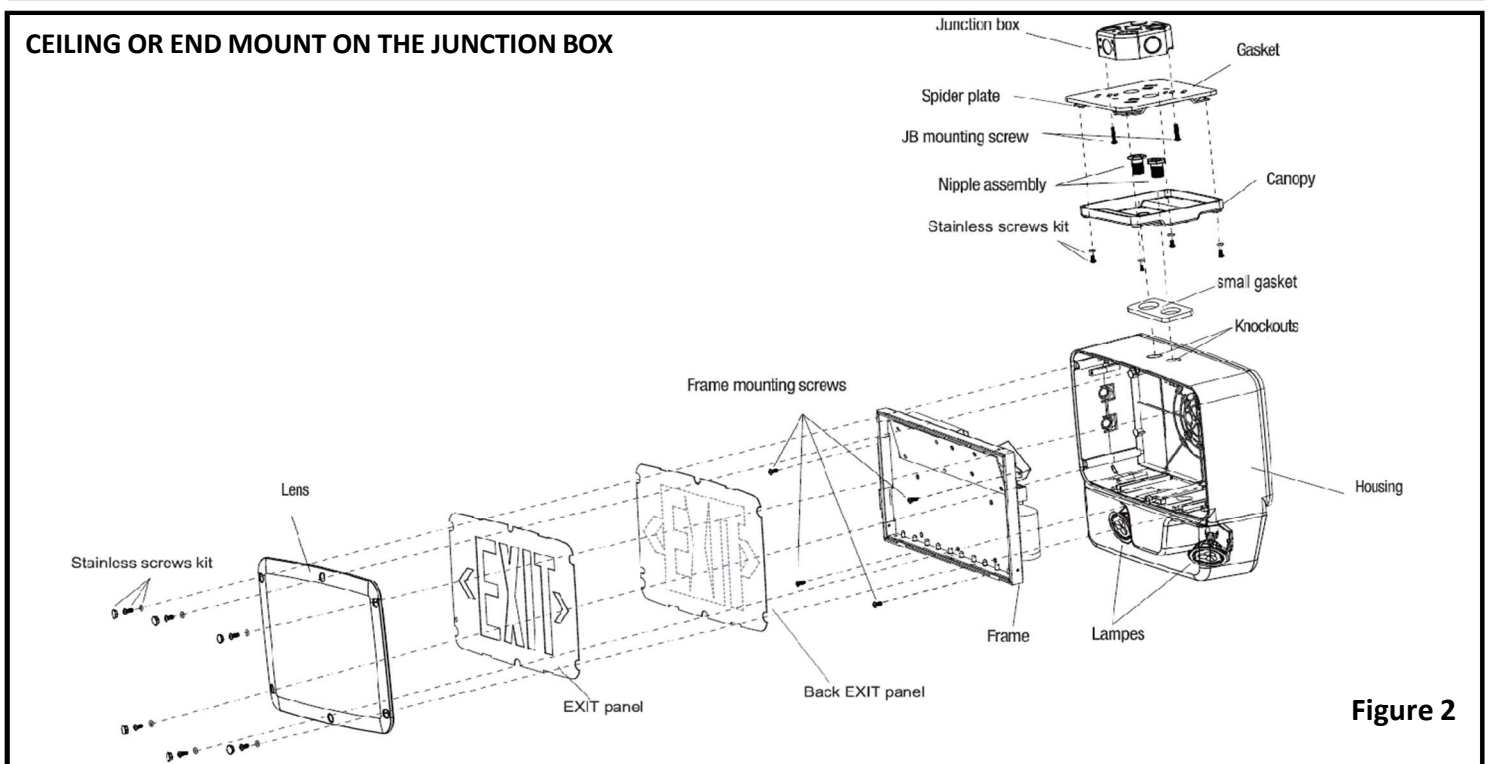
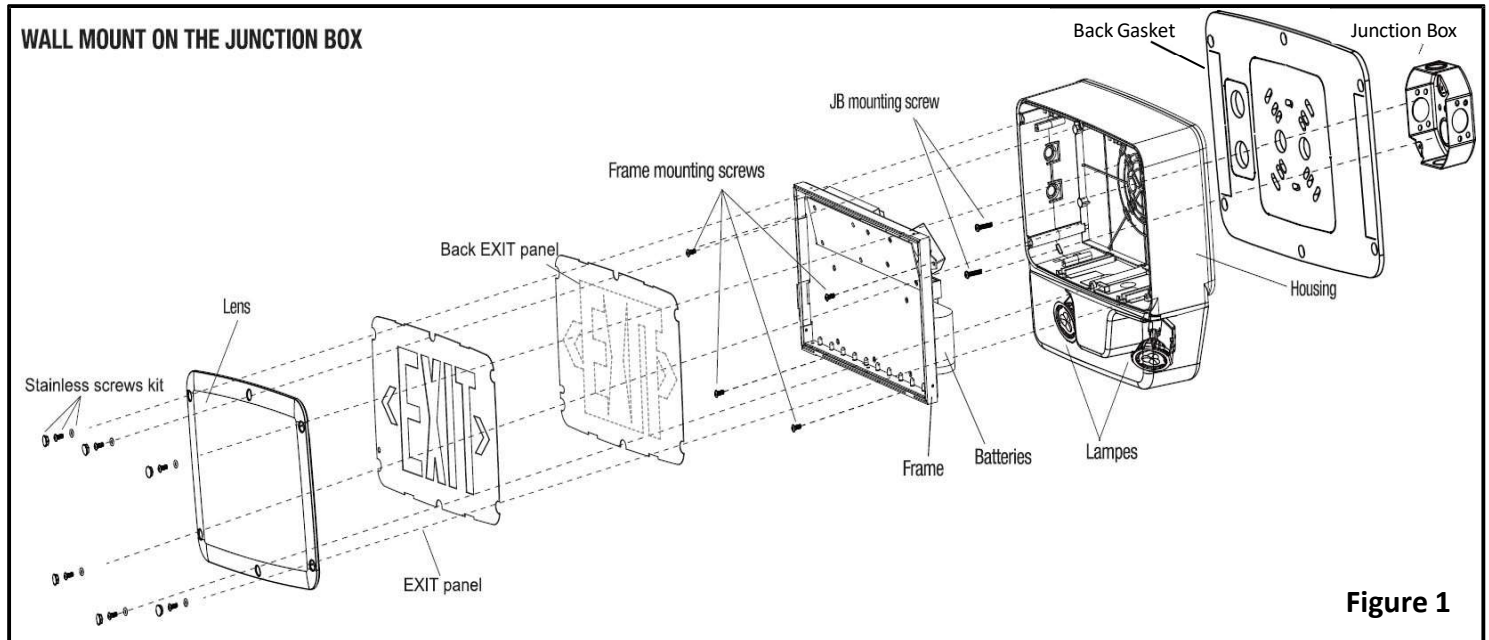

## INSTALLATION WITH MOUNTING BRACKETS

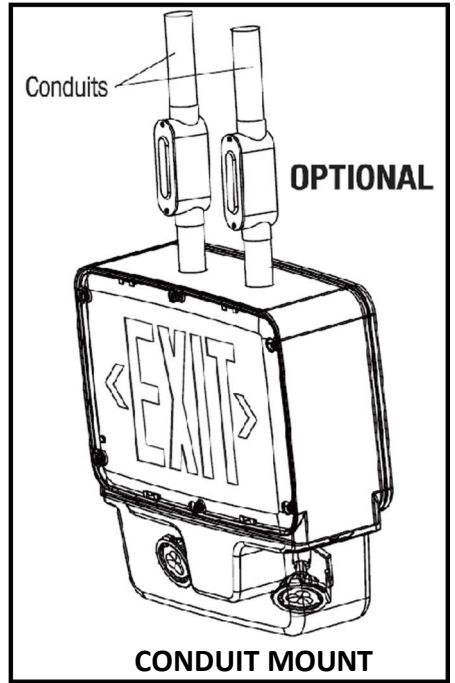
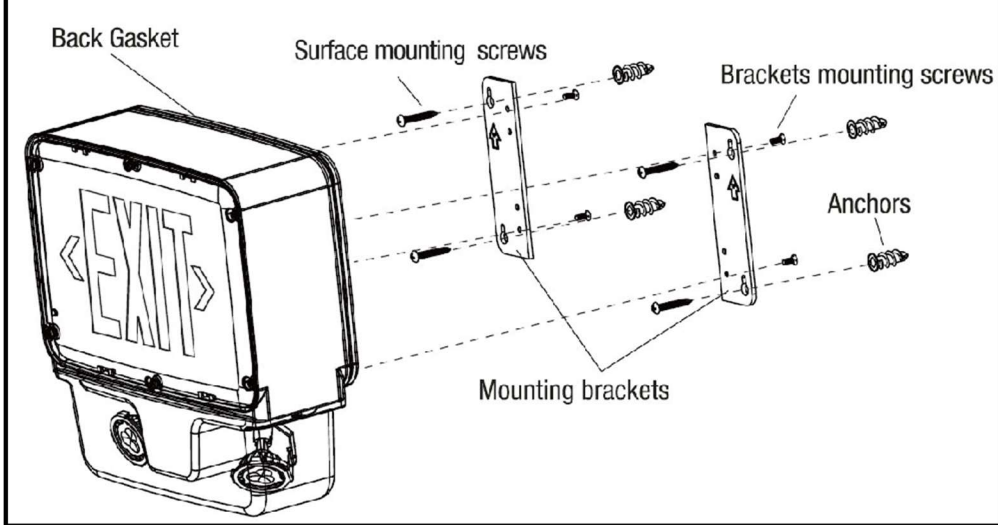

## CONDUIT MOUNT INSTALLATION

1. Remove the six screw caps and the six mounting lens screws until the EXIT lens is detachable.
2. Separate the lens and EXIT panel assembly (three pieces) from the housing. Detach the interior frame by removing the (4) frame mounting screws (Figure 2).
3. Remove the knockouts in the top or lateral side of the housing using a hammer and screwdriver.
4. Attach UL LISTED and SUITABLE FOR WET LOCATIONS conduit to the fixture housing.

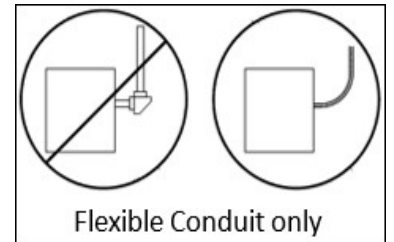
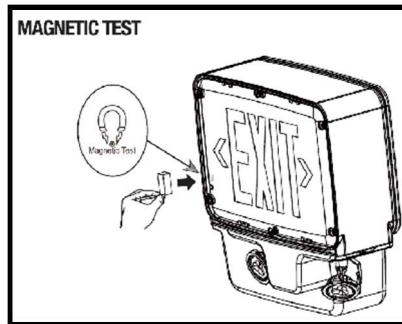

## Wiring Diagrams:

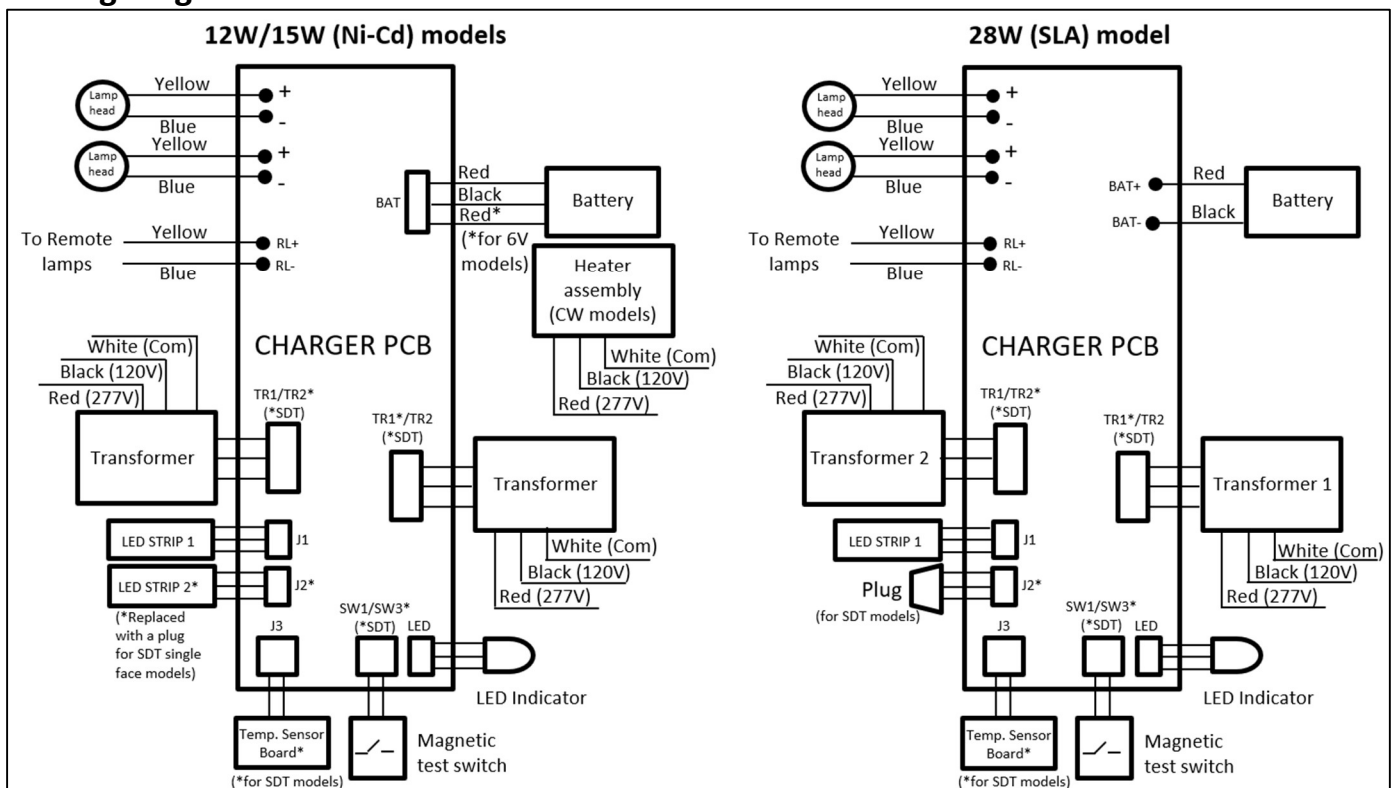

# LED INDUSTRIAL EXIT/EMERGENCY SELF-DIAGNOSTIC INSTRUCTION SHEET

## Introduction

Once the unit is properly installed (according to the Installation instructions) and AC power is supplied, the EXIT will come ON. The dual-color LED indicator will also come ON, automatically initiating the self-diagnostic test function. The LED indicator points out the current unit status. Refer to the "Fault Indication" section for more details. The LED indicator would be OFF when the unit is in Emergency mode.

## Self-Diagnostic Service

The self-diagnostic function is factory preset without any field adjustment. The automatic self-diagnostic feature serves the following tests -

- On-line real time monitoring of battery and LED(s): Identifies battery charging, disconnection and failure along with LED strip and lamphead failures.
- Self-testing and a 30-second discharge once every 30 days (conforming to NFPA code requirements), after AC power has been supplied for a minimum of 24 hours.
- Self-testing and a 30-minute discharge once every 180 days, after AC power has been supplied for a minimum of 24 hours.
- Self-testing and a 90-minute discharge once every 365 days (conforming to NFPA code requirements), after AC power has been supplied for a minimum of 24 hours.

## Fault Indication

Function	LED Indication
Battery fully charged	STEADY Green
Unit in test mode	Flashing Green
Battery Recharge	Red and Green (flashing alternatively)
Battery Disconnected	STEADY Red
Lamphead failure	Flashing Red ('3' times)
Battery Recharge Failure*	Flashing Red ('4' times)
Battery Failure**	Flashing Red
LED Strip Failure	Flashing Red ('2' times)

\* A battery recharge failure is more likely seen after a monthly or annual auto-discharge.

\*\* A battery failure is more likely seen when the unit goes into a monthly/annual discharge test and fails to run the LED strip and/or lampheads for the designated amount of time in Test/Emergency mode.

## Manual Testing

This unit can also be manually tested using the magnetic test switch. Place the magnet (provided) on the unit (near the section marked as "Magnetic Test") and pull away (at least 3 cm from the unit). This will force the unit to run a 30-second discharge test. Test can be interrupted by placing the magnet again on the unit and pulling it away. To reset the unit, place and hold the magnet for 6 seconds and then pull away.

## Operation

During an electrical power failure, the LED strip & lampheads will transfer into Emergency mode and stay LIT for a minimum of 90 minutes. The battery needs to be charged initially for 24 hours before using the magnetic test switch (to do manual test). In the test mode, the LED strip & lampheads will transfer into a SIMULATED Emergency mode with the LED indicator FLASHING Green for 30 seconds. After the test is completed, the LED strip will continue to stay **ON** and the lampheads will turn OFF.

© 2023 Signify Holding. All rights reserved. The information provided herein is subject to change, without notice. Signify does not give any representation or warranty as to the accuracy or completeness of the information included herein and shall not be liable for any action in reliance thereon. The information presented in this document is not intended as any commercial offer and does not form part of any quotation or contract, unless otherwise agreed by Signify

Signify North America Corporation  
400 Crossing Blvd, Suite 600  
Bridgewater, NJ 08807  
Telephone 833-SIGNIFY (744-6439)  
[www.chloride-lighting.com](http://www.chloride-lighting.com)