

INSTALLATION

CHLORIDE

by  Signify

WARNINGS AND INSTRUCTIONS FOR LUMINAIRES

IMPORTANT: FOR YOUR PROTECTION, YOU MUST CAREFULLY READ ALL WARNINGS AND INSTRUCTIONS IN THEIR ENTIRETY PRIOR TO INSTALLATION, OPERATION, SERVICE, OR MAINTENANCE. FAILURE TO DO SO CAN RESULT IN DEATH, PERSONAL INJURY AND PROPERTY DAMAGE. If you do not understand these warnings and instructions, or if additional information is desired, please contact the Customer Care Call Center at 800-555-0050.

- **Installation, service, and maintenance of luminaires must be performed by a qualified professional and in accordance with all federal, state, and local laws, regulations, and electrical codes. This professional should be familiar with the construction and operation of this product and any hazards involved. If not qualified, do not attempt installation, service or maintenance.**
- **To reduce the risk of death, personal injury or property damage from fire, electric shock, falling parts, cuts, abrasions, and other hazards, please read all warnings and instructions included with the luminaire, on the luminaire's packaging and affixed to the luminaire itself.**
- **Maintenance of the luminaires should be performed by person(s) familiar with the luminaire's construction and operation and any hazards involved.**
- **Use caution when servicing batteries. Battery acid can cause burns to skin and eyes. If acid is spilled on skin or eyer, flush acid with fresh water and contact a physician immediately.**



WARNING

RISK OF FIRE, ELECTRIC SHOCK OR PERSONAL INJURY

- Disconnect or turn off power before attempting any installation, service or maintenance.
- Verify that supply voltage is correct by referencing the luminaire label information.
- Make all electrical and ground connections in accordance with the National Electrical Code (NEC) and any other applicable laws, regulations, or codes.
- All wiring connections should be capped with UL-approved wire connectors.



WARNING

RISK OF PERSONAL INJURY

- Wear gloves and safety glasses at all times when removing luminaire from carton, installing, servicing or performing maintenance.
- Avoid direct eye exposure to the light source while it is on.



WARNING

RISK OF PERSONAL INJURY

- Keep combustible materials away from LED/lamp & lens.
- Do not operate in close proximity to persons, combustible materials or substances affected by heat or drying.



WARNING

RISK OF FIRE, ELECTRIC SHOCK OR PERSONAL INJURY

- Allow LED/lamp & lens to cool before handling.
- Do not touch enclosure or light source.
- Do not exceed maximum wattage marked on luminaire label.
- Follow all manufacturer's warnings, recommendations, instructions, and restrictions for driver type, burning position, mounting locations and replacement.



CAUTION

RISK OF PRODUCT DAMAGE

- Never connect luminaires and/or components under load with supply voltage turned on.
- Do not mount or support these luminaires in a manner that can cut the outer jacket or damage wire insulation.
- Do not restrict fixture ventilation. Allow for some volume of airspace around the luminaire. Avoid covering the luminaire with insulation, foam, or other material that will prevent convection or conduction cooling.
- Do not exceed luminaire maximum ambient temperature.
- Do not modify the luminaire.
- Only use luminaire in its intended application and location.
- LED products are polarity sensitive. Ensure proper polarity before installation.
- Electrostatic Discharge (ESD) can damage LED. Personal grounding equipment must be worn during all installation and servicing of the luminaire.
- Do not touch individual electrical components as this can cause ESD, shorten LED life, or impact LED performance. Some components inside the luminaire may not be serviceable. In the unlikely event, your luminaire may require service, stop using it immediately and contact the Customer Care Call Center at 800-555-0050.
- Always read the luminaire's complete installation instructions prior to installation for any additional luminaire- specific warnings.
- In the case of HID or Fluorescent luminaires, regular re-lamping is required to keep the luminaire operating within safe limits.

- **Do not install damaged products.** Handling and installing damaged products can potentially increase the risks mentioned. In case of damage and/or missing parts upon arrival of the luminaire, please contact the Customer Care Call Center at 800-555-0050.
- These instructions do not purport to cover all details or variations in equipment nor to provide every possible contingency to meet in connection with installation, operation, or maintenance. Should further information be desired, or should particular problems arise which are not covered sufficiently for the purchaser's or owner's purposes, this matter should be referred to the Customer Care Call Center at 800-555-0050.
- Please see luminaire-specific Installation and Maintenance Instruction for additional warnings or any applicable FCC or regulatory statements. Failure to follow any of these instructions could void luminaire warranties.

Luminaire Maintenance

- Regular luminaire maintenance programs are recommended.
- It is recommended to clean the outside of the luminaire and the refractor/lens.
- Frequency of cleaning will depend on ambient dirt level and minimum light output which is acceptable to the user.
- If clean water is not sufficient for cleaning, use a neutral, synthetic, non-scratching, and non-abrasive cleaning substance.
- Never use alkaline and/or acetous cleaning substances.
- Make sure that the cleaning substance is carefully removed by rinsing with lots of clean water.
- Signify recommends using a cleaning solution that has a PH between 5 and 8.
- Recycle: For information on how to recycle electronic products and components, please visit www.epa.gov.

NOTE: This equipment has been tested and found to comply with the limits for a Class A digital device, pursuant to part 15 of the FCC Rules. These limits are designed to provide reasonable protection against harmful interference when the equipment is operated in a commercial environment. This equipment generates, uses, and can radiate radio frequency energy and, if not installed and used in accordance with the instruction manual, may cause harmful interference to radio communications. Operation of this equipment in a residential area likely to cause harmful interference in which case the user will be required to correct the interference at his own expense.

INSTALLATION INSTRUCTIONS

LED INDUSTRIAL NEMA4X & NSF RATED EMERGENCY UNIT

IMPORTANT SAFEGUARDS

When using electrical equipment, basic safety precautions should always be followed, including the following.

READ AND FOLLOW ALL SAFETY INSTRUCTIONS

1. Do not let power supply cords touch hot surfaces.
2. Do not mount near gas or electric heaters.
3. Turn off electrical power before and during installation.
4. Turn off electrical power before opening the unit for maintenance or servicing.
5. Use caution when handling batteries. Battery acid can cause burns to the skin and eyes. Avoid possible shorting.
6. Equipment should be mounted in locations and at heights where it will not readily be subject to tampering by unauthorized personnel.
7. The use of accessory equipment not authorized by the manufacturer may cause an unsafe condition.
8. Do not use this equipment for other than its intended purpose.
9. Servicing of this equipment should only be performed by qualified service personnel.

Note: UL recommended maximum mounting height for this model is 16-ft

WALL MOUNT INSTALLATION

1. Extend AC of rated voltage nearby to the unit into recessed junction box (supplied by others). This circuit should NOT be energized/live at this time.
2. Remove the screw caps and loosen the four mounting lens screws until the lens is detachable. **Note:** Do not detach the four screws and eight O-rings from the lens' mounting holes.
3. Separate the lens from the fixture. Pull out the luminaire housing. Unscrew the battery brackets and pull the batteries out.
4. Determine the appropriate knockouts (K/O) to remove for mounting to the junction box. Support area around the knockouts and remove them using a hammer and screwdriver. Remove one of the ¾" knockouts in the center and route the fixture supply wires through it.
5. Place the gasket provided between the fixture's back housing and the junction box. Route the fixture supply wires through one of the circular holes in the center of the gasket.
6. Refer to the "Wiring Diagrams" section and make electrical connections inside the junction box using the wire nuts provided. Cap off the unused (Red or Black) lead.
7. Using the two screws provided and the previously removed K/O holes, mount the fixture to the surface over the recessed junction box. Tighten the screws enough to compress the gasket to ensure a good, sealed joint.
8. Install the batteries back using the brackets previously removed. Complete battery connection using the leads or connector from the PCB inside the housing. For SLA (Lead acid) battery models, refer to Fig. 1 to make the correct battery connections.
9. Attach the luminaire housing back onto the fixture. Adjust the lamps to the desired position.
10. Reinstall the lens using the four screws and eight O-rings. Tighten the screws enough (7.5 lbf-in torque is recommended) to compress the gasket to ensure a good, sealed joint. Replace the four screw caps.
11. Apply power. Allow the unit to charge for 24 hours before testing it in emergency mode.

INSTALLATION WITH MOUNTING BRACKETS

1. Extend AC of rated voltage nearby to the unit into recessed junction box (supplied by others). This circuit should NOT be energized/live at this time.
2. Remove the (2) side gaskets from the gasket sheet provided and attach the sheet to the fixture's backside.
3. Mount the (2) surface mounting brackets onto the fixture's backside and secure using the screws provided.
4. Place the housing on the required surface. Drill (4) holes using the brackets holes as a drilling template and fix the mounting anchors inside the holes.
5. Remove the screw caps and loosen the four mounting lens screws until the lens is detachable. **Note:** Do not detach the four screws and eight O-rings from the lens' mounting holes.
6. Separate the lens from the fixture. Pull out the luminaire housing. Unscrew the battery brackets and pull the batteries out.
7. Remove the appropriate knockout (K/O) from the fixture's back using a hammer and screwdriver. Route the fixture supply wires through the opening on the backplate and the gasket attached to it.
8. Refer to the "Wiring Diagrams" section and make electrical connections inside the junction box using the wire nuts provided. Cap off the unused (Red or Black) lead.
9. Install the batteries back using the brackets previously removed. Complete battery connection using the leads or connector from the PCB inside the housing. For SLA (Lead acid) battery models, refer to Fig. 1 to make the correct battery connections.
10. Attach the luminaire housing back onto the fixture. Adjust the lamps to the desired position.
11. Reinstall the lens using the four screws and eight O-rings. Tighten the screws enough (7.5 lbf-in torque is recommended) to compress the gasket to ensure a good, sealed joint. Replace the four screw caps.
12. Mount the fixture to the surface using the (4) mounting screws and previously installed screw anchors.
13. Apply power. For units with battery, allow the unit to charge for 24 hours before testing it in emergency mode.

CONDUIT MOUNT INSTALLATION

1. Remove the screw caps and loosen the four mounting lens screws until the lens is detachable. **Note:** Do not detach the four screws and eight O-rings from the lens' mounting holes.
2. Separate the lens from the fixture. Pull out the luminaire housing. Unscrew the battery brackets and pull the batteries out.
3. Remove the knockouts in the top side of the housing using a hammer and screwdriver.
4. Attach UL LISTED and SUITABLE FOR WET LOCATIONS conduit to the fixture housing.

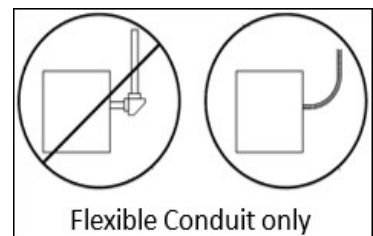
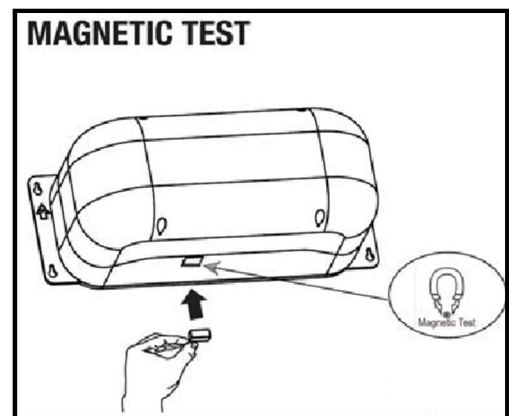

INSTALLATION ON THE JUNCTION BOX

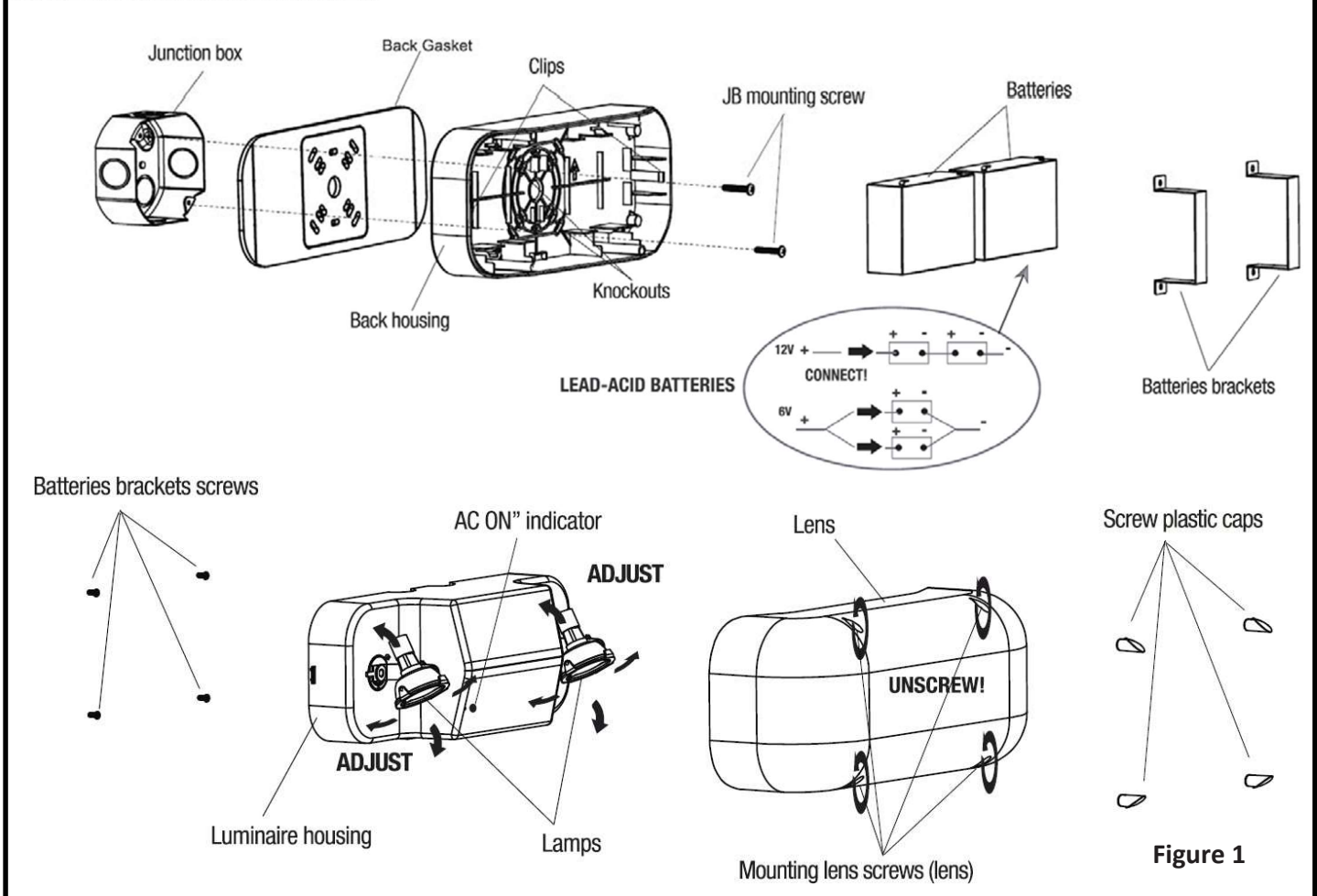

INSTALLATION WITH MOUNTING BRACKETS

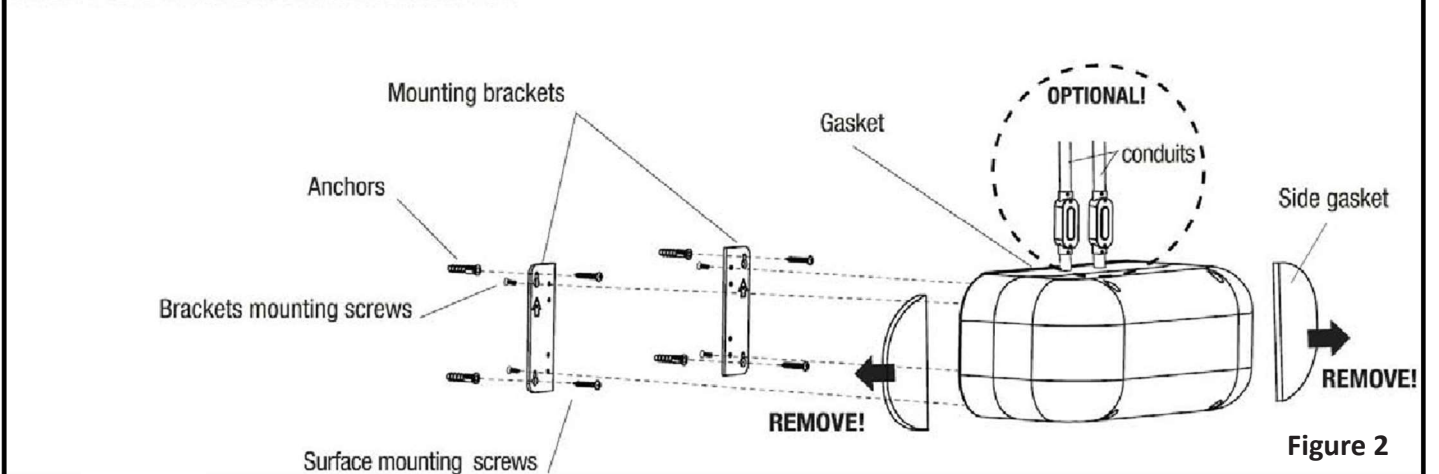

OPERATION

1. Apply AC power to the unit. The LED indicator will be GREEN.
2. After the battery has been left to charge for 2 hours, test the unit using the magnetic test switch. The LED indicator turns OFF and the lamphads should turn ON at this time.
3. When the magnet is removed, the LED indicator turns back to GREEN, and the lamphads should turn OFF at this time.

Wiring Diagrams:

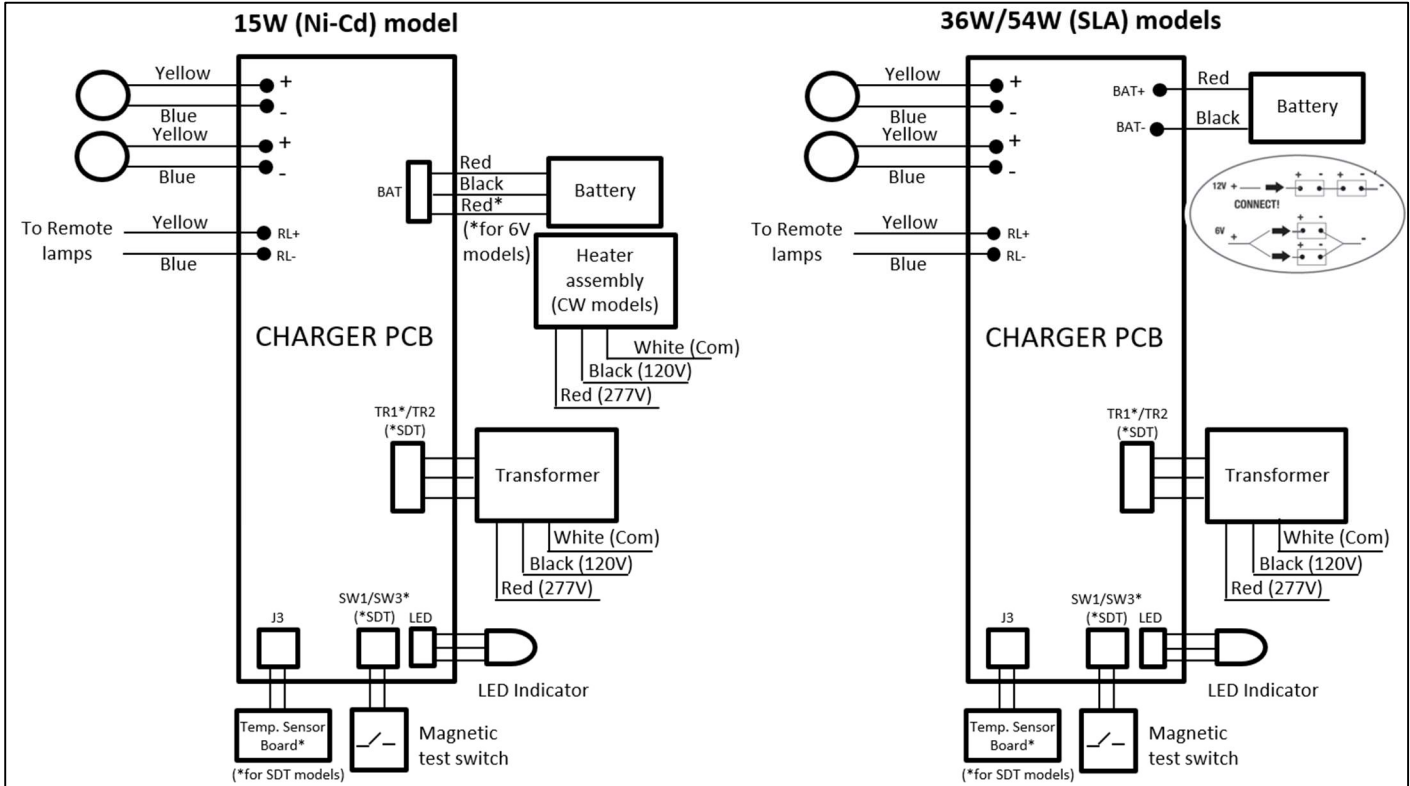

LED STATUS INDICATOR KEY and TROUBLESHOOTING

LED status	Indication	Action to take
Red	<ol style="list-style-type: none"> Battery connection is not made Battery has been diagnosed as dead or defective after 24 hours of continuous charging with AC power supplied 	<ol style="list-style-type: none"> Make connection; or if battery is connected, disconnect battery for eight seconds and then reconnect. Replace the battery.
Green	Battery is connected, AC power has been supplied and fixture is in charging state.	This is the normal state. No action required.
Unlit	AC power has not been supplied or unit is in EM mode	Supply AC power or wait until utility power is restored

MAINTENANCE

Caution: Always turn off AC power to the equipment before servicing. Servicing should be performed only by a qualified service technician. Use only MANUFACTURER supplied replacement parts.

BATTERY: The battery supplied requires no maintenance. However, it should be tested periodically and replaced when it no longer operates the connected unit for the duration of a 30-second or 90-minute test.

TESTING

National Electric Code (NEC) and NFPA 101 current Life Safety code requirements require that routine tests need to be performed as listed below: Once every month, the unit needs to be tested for duration of 30 seconds. Place and hold the magnet near the magnetic switch on the fixture to perform this test. Once every 12 months, a full 90-minute (per UL requirements) test needs to be performed on the unit. Disconnect power to the unit and leave it in the emergency mode. The lamps should stay ON for at least 90 minutes. Written records of the testing are to be kept for examination by the authority having jurisdiction.

LED INDUSTRIAL EMERGENCY UNIT SELF-DIAGNOSTIC INSTRUCTION SHEET

Introduction

Once the unit is properly installed according to the Installation instructions and AC power is supplied the dual-color LED indicator will come ON, automatically initiating the self-diagnostic test function. The LED indicator points out the current unit status. Refer to "Fault Indication" section for more details. The LED indicator would be OFF when the unit is in Emergency mode.

Self-Diagnostic Service

The self-diagnostic function is factory preset without any field adjustment. The automatic self-diagnostic feature serves the following tests -

- On-line real time monitoring of battery and LED(s): Identifies battery charging, disconnection and failure along with lamphead failures.
- Self-testing and a 30-second discharge once every 30 days (conforming to NFPA code requirements), after AC power has been supplied for a minimum of 24 hours.
- Self-testing and a 30-minute discharge once every 180 days, after AC power has been supplied for a minimum of 24 hours.
- Self-testing and a 90-minute discharge once every 365 days (conforming to NFPA code requirements), after AC power has been supplied for a minimum of 24 hours.

Fault Indication

Function	LED Indication
Battery fully charged	STEADY Green
Unit in test mode	Flashing Green
Battery Recharge	Red and Green (flashing alternatively)
Battery Disconnected	STEADY Red
Lamphead failure	Flashing Red ('3' times)
Battery Recharge Failure*	Flashing Red ('4' times)
Battery Failure**	Flashing Red

* A battery recharge failure is more likely seen after a monthly or annual auto-discharge.

** A battery failure is more likely seen when the unit goes into a monthly/annual discharge test and/or fails to run the lampheads for the designated amount of time in Test/Emergency mode.

Manual Testing

This unit can also be manually tested using the magnetic test switch. Place the magnet (provided) on the unit (near the section marked as "Magnetic Test") and pull away (at least 3 cm from the unit). This will force the unit to run a 30-second discharge test. Test can be interrupted by placing the magnet again on the unit and pulling it away. To reset the unit, place and hold the magnet for 6 seconds and then pull away.

Operation

During an electrical power failure, the lampheads will transfer into Emergency mode and stay LIT for a minimum of 90 minutes. The battery needs to be charged initially for 24 hours before using the magnetic test switch (to do manual test). In the test mode, the lampheads will transfer into a SIMULATED Emergency mode with the LED indicator FLASHING Green for 30 seconds. After the test is completed, the lampheads would turn OFF.