

# INSTALLATION

# CHLORIDE

## WARNINGS AND INSTRUCTIONS FOR LUMINAIRES

by  Signify

**IMPORTANT:** FOR YOUR PROTECTION, YOU MUST CAREFULLY READ ALL WARNINGS AND INSTRUCTIONS IN THEIR ENTIRETY PRIOR TO INSTALLATION, OPERATION, SERVICE, OR MAINTENANCE. FAILURE TO DO SO CAN RESULT IN DEATH, PERSONAL INJURY AND PROPERTY DAMAGE. If you do not understand these warnings and instructions, or if additional information is desired, please contact the Customer Care Call Center at 800-555-0050.

- **Installation, service, and maintenance of luminaires must be performed by a qualified professional and in accordance with all federal, state, and local laws, regulations, and electrical codes. This professional should be familiar with the construction and operation of this product and any hazards involved. If not qualified, do not attempt installation, service or maintenance.**
- **To reduce the risk of death, personal injury or property damage from fire, electric shock, falling parts, cuts, abrasions, and other hazards, please read all warnings and instructions included with the luminaire, on the luminaire's packaging and affixed to the luminaire itself.**
- **Maintenance of the luminaires should be performed by person(s) familiar with the luminaire's construction and operation and any hazards involved.**



### WARNING

#### RISK OF FIRE, ELECTRIC SHOCK OR PERSONAL INJURY

- Disconnect or turn off power before attempting any installation, service or maintenance.
- Verify that supply voltage is correct by referencing the luminaire label information.
- Make all electrical and ground connections in accordance with the National Electrical Code (NEC) and any other applicable laws, regulations, or codes.
- All wiring connections should be capped with UL-approved wire connectors.



### WARNING

#### RISK OF PERSONAL INJURY

- Wear gloves and safety glasses at all times when removing luminaire from carton, installing, servicing or performing maintenance.
- Avoid direct eye exposure to the light source while it is on.



### WARNING

#### RISK OF PERSONAL INJURY

- Keep combustible materials away from LED/lamp & lens.
- Do not operate in close proximity to persons, combustible materials or substances affected by heat or drying.



### WARNING

#### RISK OF FIRE, ELECTRIC SHOCK OR PERSONAL INJURY

- Allow LED/lamp & lens to cool before handling.
- Do not touch enclosure or light source.
- Do not exceed maximum wattage marked on luminaire label.
- Follow all manufacturer's warnings, recommendations, instructions, and restrictions for driver type, burning position, mounting locations and replacement.



### CAUTION

#### RISK OF PRODUCT DAMAGE

- Never connect luminaires and/or components under load with supply voltage turned on.
- Do not mount or support these luminaires in a manner that can cut the outer jacket or damage wire insulation.
- Do not restrict fixture ventilation. Allow for some volume of airspace around the luminaire. Avoid covering the luminaire with insulation, foam, or other material that will prevent convection or conduction cooling.
- Do not exceed luminaire maximum ambient temperature.
- Do not modify the luminaire.
- Only use luminaire in its intended application and location.
- LED products are polarity sensitive. Ensure proper polarity before installation.
- Electrostatic Discharge (ESD) can damage LED. Personal grounding equipment must be worn during all installation and servicing of the luminaire.
- Do not touch individual electrical components as this can cause ESD, shorten LED life, or impact LED performance.  
Some components inside the luminaire may not be serviceable. In the unlikely event, your luminaire may require service, stop using it immediately and contact the Customer Care Call Center at 800-555-0050.
- Always read the luminaire's complete installation instructions prior to installation for any additional luminaire-specific warnings.
- In the case of HID or Fluorescent luminaires, regular re-lamping is required to keep the luminaire operating within safe limits.
- **Do not install damaged products.** Handling and installing damaged products can potentially increase the risks mentioned. In case of damage and/or missing parts upon arrival of the luminaire, please contact the Customer Care Call Center at 800-555-0050.

---

# INSTALLATION INSTRUCTIONS FOR CSE[X]RWW EXIT SIGN

---

- These instructions do not purport to cover all details or variations in equipment nor to provide every possible contingency to meet in connection with installation, operation, or maintenance. Should further information be desired, or should particular problems arise which are not covered sufficiently for the purchaser's or owner's purposes, this matter should be referred to the Customer Care Call Center at 800-555-0050.
- Please see luminaire-specific Installation and Maintenance Instruction for additional warnings or any applicable FCC or regulatory statements. Failure to follow any of these instructions could void luminaire warranties.

## **Luminaire Maintenance and Operation**

- Regular luminaire maintenance programs are recommended.
- It is recommended to clean the outside of the luminaire and the refractor/lens.
- Frequency of cleaning will depend on ambient dirt level and minimum light output which is acceptable to the user.
- If clean water is not sufficient for cleaning, use a neutral, synthetic, non-scratching, and non-abrasive cleaning substance.
- Never use alkaline and/or acetous cleaning substances.
- Make sure that the cleaning substance is carefully removed by rinsing with lots of clean water.
- Signify recommends using a cleaning solution that has a PH between 5 and 8.
- Recycle: For information on how to recycle electronic products and components, please visit [www.epa.gov](http://www.epa.gov).
- To test self powered units, depress test switch, lamp head will remain lit when switched to battery power.
- Release test switch, lamp head will operate with AC supply.
- Servicing of any parts should be performed by qualified personnel. For replacement parts to see fixture label for proper identification of manufactory.
- Replace batteries according to ambient conditions. Equipment should be tested regularly in accordance with local codes.
- Max mounting height: 35 ft.

**CAUTION:** This equipment used special circuit diagram to protection for LiFePO<sub>4</sub> battery overcharge and over discharge. Allow 24 hour recharge time after installation or power failure for full load testing.

NOTE: This equipment has been tested and found to comply with the limits for a Class A digital device, pursuant to part 15 of the FCC Rules. These limits are designed to provide reasonable protection against harmful interference when the equipment is operated in a commercial environment. This equipment generates, uses, and can radiate radio frequency energy and, if not installed and used in accordance with the instruction manual, may cause harmful interference to radio communications. Operation of this equipment in a residential area likely to cause harmful interference in which case the user will be required to correct the interference at his own expense.

## WIRING DIAGRAM

### AC wiring

Connect the white wire to neutral, connect the black wire to the hot lead, connect the green wire to ground.

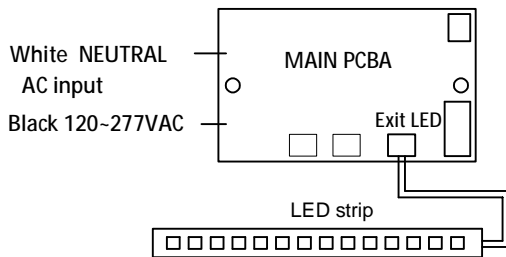

Fig 1

## PREPARATION WORK FOR INSTALLATION

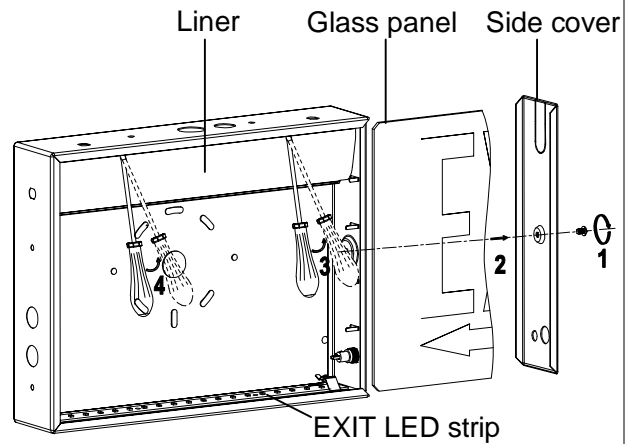

Fig 2

## WALL MOUNT INSTALLATION

- Step 1. Extend unswitched 24 hour AC supply of rated voltage to junction box. Leave at least 18 inches of slack. Circuit should not be energized at this time.
- Step 2. Disassemble glass panel by removing the screw holding side cover, use flat head screwdriver to open the liner. See Fig 2.
- Step 3. Knock out the appropriate mounting pattern and wire pass hole to match junction box. Insert bushing into wire access hole to prevent abrasion on supply wires, bring wires through back of fixture.
- Step 4. Connect power supply and ground in accordance with local codes. Neutral line to white lead, 120V or 277V Live line to black lead, ground to green lead. Splice connections must be pushed back into the junction box.
- Step 5. Mount to junction box.
- Step 6. Energize AC supply, LED will come on.
- Step 7. Fasten liner back, slide the glass panel back to housing, reassemble side cover and screw removed in Step 2.

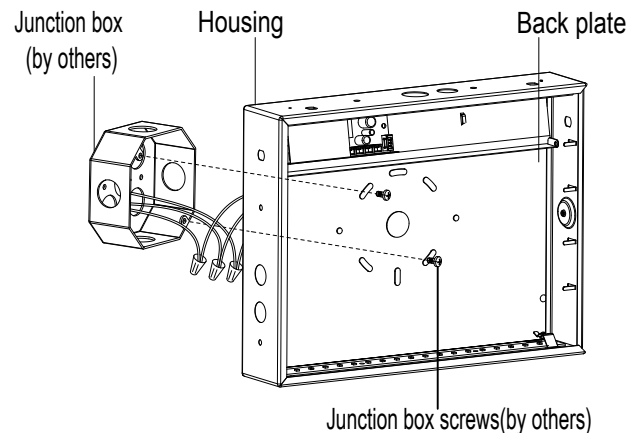

Fig 3

## CEILING OR SIDE MOUNT INSTALLATION

- Step 1. Extend unswitched AC supply of rated voltage to junction box. Leave at least 18" of slack. Circuit should not be energized at this time.
- Step 2. Disassemble glass panel by removing the screw holding the side cover, use flat head screwdriver to open the liner. See Fig 2.
- Step 3. Knock out the appropriate mounting pattern on top or side of housing to accommodate canopy.
- Step 4. Fasten canopy to exit housing by means of two #8-32x3/8 screws and nuts.
- Step 5. Feed unswitched AC supply through center of crossbar. Mount crossbar to junction box by choosing proper slots and using screws supplied with junction box.
- Step 6. Feed wires through exit housing and canopy.

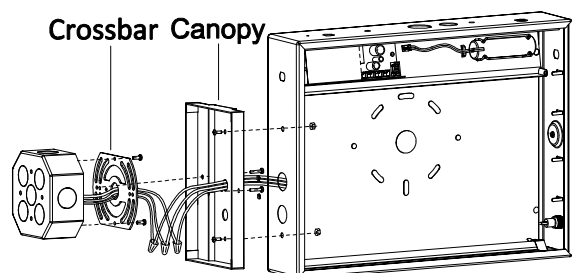

Fig 4

- Step 7. Connect power supply and ground in accordance with local codes. Neutral line to white lead, 120V or 277V Live line to black lead, ground to green lead. Splice connections must be pushed back into the junction box.
- Step 8. Mount exit-canopy assembly to crossbar using two #8-32x1 screws.
- Step 9. When side mounting, route wires along top and side edges of exit frame. Use wire manager provided to hold wires flush to inside of housing.
- Step 10. Energize AC supply, LED will come on.
- Step 11. Fasten liner back, slide the glass panel into the housing, reassemble side cover and screw removed in Step 2.
- [The following steps required when converting to double (2) face.]
- Step 12. Fasten liner back, remove backplate, slide the glass panels into the housing. (take note to confirm direction of panels)

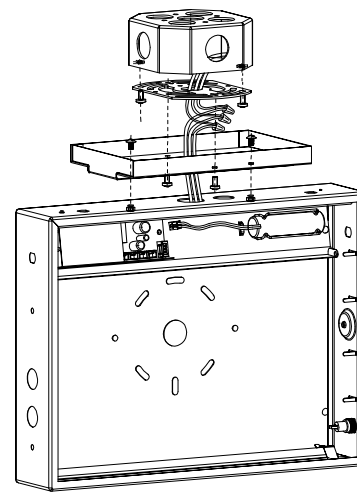

Fig 5

### CONDUIT MOUNT INSTALLATION

- Step 1. Extend unswitched AC supply of rated voltage to conduit. Leave at least 18" of slack. Circuit should not be energized at this time.
- Step 2. Disassemble glass panel by removing the screw holding the side cover, use flat head screwdriver to open the liner. See Fig 2.
- Step 3. Knock out the mounting pattern on top of the sign housing.
- Step 4. Feed wires through the center hole and fasten conduit to exit housing by conduit nut.
- Step 5. Connect power supply and ground in accordance with local codes. Neutral line to white lead, 120V or 277V Live line to black lead, ground to green lead. Splice connections must be enclosed by liner.
- Step 6. Energize AC supply, LED will come on.
- Step 7. Fasten liner back, slide the glass panel into the housing, reassemble side cover and screw removed in Step 2.
- [The following steps required when converting to double (2) face.]
- Step 8. Fasten liner back, remove backplate, slide the glass panels into the housing. (take note to confirm direction of panels)

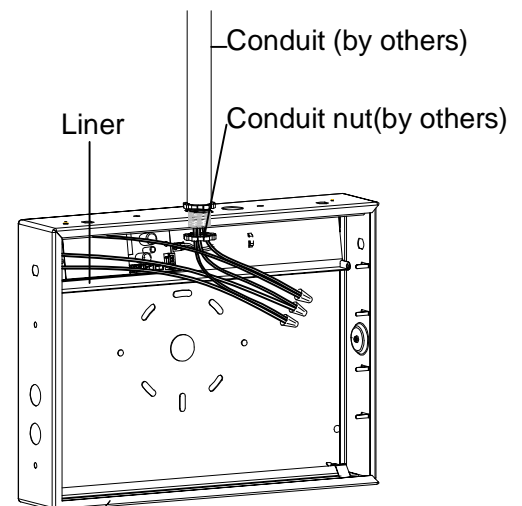

Fig 6

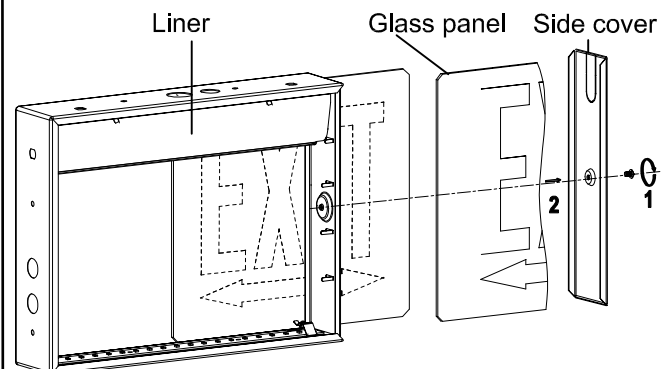

Fig 7