

INSTALLATION

CHLORIDE

by  Signify

WARNINGS AND INSTRUCTIONS FOR LUMINAIRES

IMPORTANT: FOR YOUR PROTECTION, YOU MUST CAREFULLY READ ALL WARNINGS AND INSTRUCTIONS IN THEIR ENTIRETY PRIOR TO INSTALLATION, OPERATION, SERVICE, OR MAINTENANCE. FAILURE TO DO SO CAN RESULT IN DEATH, PERSONAL INJURY AND PROPERTY DAMAGE. If you do not understand these warnings and instructions, or if additional information is desired, please contact the Customer Care Call Center at 800-555-0050.

- **Installation, service, and maintenance of luminaires must be performed by a qualified professional and in accordance with all federal, state, and local laws, regulations, and electrical codes. This professional should be familiar with the construction and operation of this product and any hazards involved. If not qualified, do not attempt installation, service or maintenance.**
- **To reduce the risk of death, personal injury or property damage from fire, electric shock, falling parts, cuts, abrasions, and other hazards, please read all warnings and instructions included with the luminaire, on the luminaire's packaging and affixed to the luminaire itself.**
- **Maintenance of the luminaires should be performed by person(s) familiar with the luminaire's construction and operation and any hazards involved.**

**WARNING**
RISK OF FIRE, ELECTRIC SHOCK OR PERSONAL INJURY

- Disconnect or turn off power before attempting any installation, service or maintenance.
- Verify that supply voltage is correct by referencing the luminaire label information.
- Make all electrical and ground connections in accordance with the National Electrical Code (NEC) and any other applicable laws, regulations, or codes.
- All wiring connections should be capped with UL-approved wire connectors.

**WARNING**
RISK OF PERSONAL INJURY

- Wear gloves and safety glasses at all times when removing luminaire from carton, installing, servicing or performing maintenance.
- Avoid direct eye exposure to the light source while it is on.

**WARNING**
RISK OF PERSONAL INJURY

- Keep combustible materials away from LED/lamp & lens.
- Do not operate in close proximity to persons, combustible materials or substances affected by heat or drying.

**WARNING**
RISK OF FIRE, ELECTRIC SHOCK OR PERSONAL INJURY

- Allow LED/lamp & lens to cool before handling.
- Do not touch enclosure or light source.
- Do not exceed maximum wattage marked on luminaire label.
- Follow all manufacturer's warnings, recommendations, instructions, and restrictions for driver type, burning position, mounting locations and replacement.



CAUTION

RISK OF PRODUCT DAMAGE

- Never connect luminaires and/or components under load with supply voltage turned on.
- Do not mount or support these luminaires in a manner that can cut the outer jacket or damage wire insulation.
- Do not restrict fixture ventilation. Allow for some volume of airspace around the luminaire. Avoid covering the luminaire with insulation, foam, or other material that will prevent convection or conduction cooling.
- Do not exceed luminaire maximum ambient temperature.
- Do not modify the luminaire.
- Only use luminaire in its intended application and location.
- LED products are polarity sensitive. Ensure proper polarity before installation.
- Electrostatic Discharge (ESD) can damage LED. Personal grounding equipment must be worn during all installation and servicing of the luminaire.
- Do not touch individual electrical components as this can cause ESD, shorten LED life, or impact LED performance. Some components inside the luminaire may not be serviceable. In the unlikely event, your luminaire may require service, stop using it immediately and contact the Customer Care Call Center at 800-555-0050.
- Always read the luminaire's complete installation instructions prior to installation for any additional luminaire-specific warnings.
- In the case of HID or Fluorescent luminaires, regular re-lamping is required to keep the luminaire operating within safe limits.

- **Do not install damaged products.** Handling and installing damaged products can potentially increase the risks mentioned. In case of damage and/or missing parts upon arrival of the luminaire, please contact the Customer Care Call Center at 800-555-0050.
- These instructions do not purport to cover all details or variations in equipment nor to provide every possible contingency to meet in connection with installation, operation, or maintenance. Should further information be desired, or should particular problems arise which are not covered sufficiently for the purchaser's or owner's purposes, this matter should be referred to the Customer Care Call Center at 800-555-0050.
- Please see luminaire-specific Installation and Maintenance Instruction for additional warnings or any applicable FCC or regulatory statements. Failure to follow any of these instructions could void luminaire warranties.

Luminaire Maintenance

- Regular luminaire maintenance programs are recommended.
- It is recommended to clean the outside of the luminaire and the refractor/lens.
- Frequency of cleaning will depend on ambient dirt level and minimum light output which is acceptable to the user.
- If clean water is not sufficient for cleaning, use a neutral, synthetic, non-scratching, and non-abrasive cleaning substance.
- Never use alkaline and/or acetous cleaning substances.
- Make sure that the cleaning substance is carefully removed by rinsing with lots of clean water.
- Signify recommends using a cleaning solution that has a PH between 5 and 8.
- Recycle: For information on how to recycle electronic products and components, please visit www.epa.gov.

Note: This equipment has been tested and found to comply with the limits for a Class B digital device, pursuant to part 15 of the FCC Rules. These limits are designed to provide reasonable protection against harmful interference in a residential installation. This equipment generates, uses, and can radiate radio frequency energy and, if not installed and used in accordance with the instructions, may cause harmful interference to radio communications. However, there is no guarantee that interference will not occur in a particular installation. If this equipment does cause harmful interference to radio or television reception, which can be determined by turning the equipment off and on, the user is encouraged to try to correct the interference by one or more of the following measures:

- Reorient or relocate the receiving antenna.
- Increase the separation between the equipment and receiver.
- Connect the equipment into an outlet on a circuit different from that to which the receiver is connected.
- Consult the dealer or an experienced radio/TV technician for help.

INSTALLATION INSTRUCTIONS

COMPACT WET LOCATION COMBO EXIT / EMERGENCY LIGHT

IMPORTANT SAFEGUARDS

CAUTION: For safety and proper operation, read and follow instructions carefully before installation.

READ AND FOLLOW ALL SAFETY INSTRUCTIONS

SAVE THESE INSTRUCTIONS AND DELIVER TO OWNER AFTER INSTALLATION

WARNING: RISK OF ELECTRIC SHOCK – NEVER CONNECT TO, DISCONNECT FROM, OR SERVICE WHILE EQUIPMENT IS ENERGIZED.

WARNING: FAILURE TO FOLLOW THESE INSTRUCTIONS AND WARNINGS MAY RESULT IN DEATH, SERIOUS INJURY OR SIGNIFICANT PROPERTY DAMAGE – For your protection read and follow these warnings and instructions carefully before installing or maintaining this equipment. These instructions do not attempt to cover all installation and maintenance situations.

- All service shall be performed by qualified personnel. This product must be installed and maintained in accordance with the applicable installation codes by a person familiar with the construction operation of the product and the hazards involved.
- This product must be installed in accordance with the applicable installation codes and ordinances.
- Before wiring to power supply, turn off electricity at fuse or circuit breaker.
- Disconnect A.C. power and unplug battery before servicing.
- Consult your local building code for approved wiring and installation.
- UL listed for wet locations (-20°C-50°C).
- Do not let the power supply cord touch hot surfaces.
- Do not mount near gas or electric heater.
- Equipment should be mounted in locations and at heights where it will not be readily subjected to tampering by unauthorized personnel.
- The use of accessory equipment not recommended by the manufacturer may cause an unsafe condition.
- Do not use this equipment for other than intended use.
- The AC voltage rating of this equipment is specified on the product label. Do not connect equipment to any other voltage.



WALL MOUNT INSTALLATION

1. Use flat head screwdriver to loosen the screws on **LENSES (A)**.
2. Remove lens, from sign; set aside.
3. Remove **EXIT STENCIL (B)** from **FIXTURE FRAME (C)**; set aside.
4. Drill or knock out appropriate knockouts on **BACK PLATE (M)** to fit junction box mounting points.
5. Drill or knock out holes in back plate for fixture supply wire leads.
6. Remove backing from self-adhesive **JUNCTION BOX GASKET (F)** and adhere to back plate.
7. Route fixture input wires through center hole of the back plate and make wiring connection. For 120V, use black and white wires and for 277V, use red and white wires. **WARNING:** Properly insulate lead with a wire nut (provided) or other approved means.
8. Secure back plate to **JUNCTION BOX (J)** (hardware not included).
9. Remove proper chevron(s) from the face plate as required. When removing chevrons, it may be helpful to remove the color diffuser panel to allow easier access to the chevrons. When removing color diffuser panel, it is important to remember to reinstall the diffuser panel once chevron(s) have been removed.
10. Connect battery to lamp board (see wiring diagrams on page 5).
11. Secure face plate and back plate to the fixture frame.
12. Secure lens to fixture and securely torque screws (7.5 lbf-in torque is recommended).
13. Apply continuous AC power. Unit can be tested by holding the magnet (provided) near the LED indicator (where it's marked "Magnetic Test Switch").
14. Magnet needs to be retained by building owner (or maintenance personnel) to perform monthly/annual inspections.

CEILING OR END MOUNT INSTALLATION

1. Use flat head screwdriver to loosen the screws on the **LENSES (A)**.
2. Remove lens, from sign, set aside.
3. Remove **EXIT STENCIL (B)** from **FIXTURE FRAME (C)**, set aside.
4. Drill $\frac{3}{4}$ " holes through the desired mounting knock outs located on the fixture frame. For ceiling mount, knock outs will be located on the top of the fixture frame. For wall mount, knock outs will be located on the side of the fixture frame.
5. Using provided hardware, thread **NUTS (D)** onto **PIPE NIPPLES (E)**. Slide pipe nipples through canopy holes.
6. Remove backing from self-adhesive **JUNCTION BOX GASKET (F)** and adhere to back of **MOUNTING PLATE (G)**. Remove backing from self-adhesive **PIPE THREAD GASKET (H)** and adhere to front of **MOUNTING CANOPY (I)**.
7. Place screws (provided) in holes on the mounting canopy.
8. Route fixture input wires through knockout in fixture frame, pipe nut and metal mounting plate.
9. Make wiring connection. For 120V, use black and white wires and for 277V, use red and white wires. **WARNING:** Properly insulate the unused lead with a wire nut (provided) or other approved means.
10. Push wire connections into the **J-BOX (J)**. Secure mounting plate to junction box (hardware not included).
11. Secure the canopy to the steel mounting plate with screws installed in step 7.
12. Place pipe nipple through the mounting hole of the fixture frame until the gasket is touching the frame. Thread a second nut onto the pipe nipple on the inside of the fixture frame to lock the canopy into place. Once the canopy is locked into position there will not be any side-to-side movement of the canopy.
13. Remove proper chevron(s) as required. When removing chevrons, it may be helpful to remove the color diffuser panel to allow easier access to the chevrons. When removing color diffuser panel, it is important to remember to reinstall the diffuser panel once chevron(s) have been removed.
14. Connect battery to lamp board (see wiring diagrams on next page).
15. Secure face plate(s) to the fixture frame.
16. Secure lens to fixture and securely torque screws (7.5 lbf-in torque is recommended).
17. Apply continuous AC power. Unit can be tested by holding magnet (provided) near the LED indicator (where it's marked as "Magnetic Test Switch").
18. Magnet needs to be retained by building owner (or maintenance personnel) to perform monthly/annual inspections.

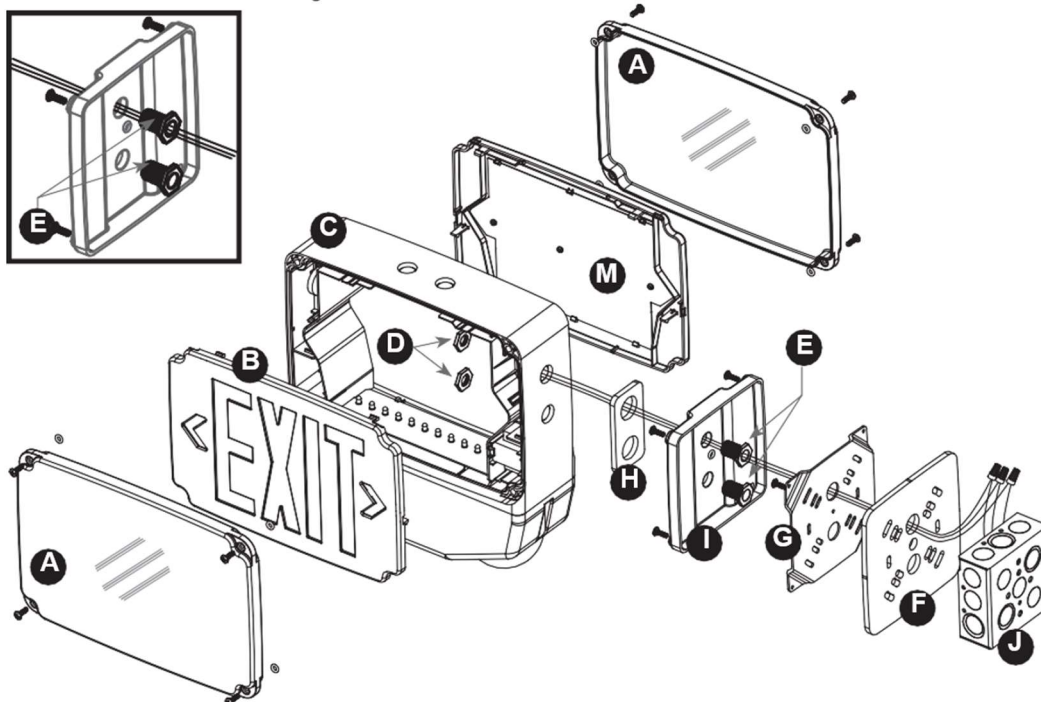

CONDUIT ENTRY

1. Drill a $\frac{3}{4}$ " hole through the desired conduit entry knock out located on the top or side of the frame of the sign.
2. Route the AC input conduit into housing.
3. All conduit connections must use UL LISTED and SUITABLE FOR WET LOCATION parts.
4. To finish installation of fixture, reference Wall, Ceiling or End Mount instructions.

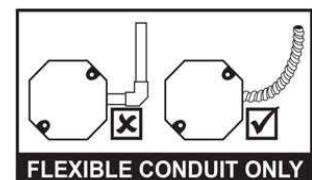

OPERATION

1. Apply AC power to the unit. The LED indicator will be GREEN.
2. After the battery has been left to charge for 2 hours, test the unit using the magnetic test switch. The LED indicator turns OFF, the LED board stays ON and the lampheads should turn ON at this time.
3. When the magnet is removed, the LED indicator turns back to GREEN, the LED board stays ON and the lampheads should turn OFF at this time.

MAINTENANCE

Caution: Always turn off AC power to the equipment before servicing. Servicing should be performed only by a qualified service technician. Use only MANUFACTURER supplied replacement parts.

BATTERY: The battery supplied requires no maintenance. However, it should be tested periodically and replaced when it no longer operates the connected sign for the duration of a 30-second or 90-minute test. The battery supplied in this sign has a life expectancy of 5 years when used in a normal ambient temperature of 72°F.

NFPA 101 (Life Safety Code) requires that all emergency lighting equipment be functionally tested every 30 days for a minimum of 30 seconds and tested annually for a full 90-minute duration. Written records of the testing are to be kept for examination by the authority having jurisdiction.

Wiring Diagrams

