



Gardco DuraForm small floodlight provides seamless replacement of existing HID luminaires. This luminaire is available in three sizes (also see FLDM and FLDL), offers multiple lumen packages, and a complete array of optical distributions, making it an outstanding solution for all types of floodlighting applications - from landscape and parks to industrial and infrastructure. Includes Service Tag, Signify's innovative way to provide assistance throughout the life of the product.

Project: _____
 Location: _____
 Cat.No: _____
 Type: _____
 Lumens: _____ Qty: _____
 Notes: _____

Ordering guide

example: FLDS-A02-740-RSP-SLF-120-PCB-BZ

Prefix	Configuration (nominal lumens)	Color Temperature	Distribution	Mounting	Voltage
FLDS					
FLDS DuraForm small	A01 3,400 A02 4,900 A03 6,100 A04 6,800 A05 9,800 A06 12,200	730 70CRI 3000K 740 70CRI 4000K 750 ⁹ 70CRI 5000K (750 - Special, contact factory)	SPT Spot 12° Round (NEMA 2x2) RSP Rectangular Spot (NEMA 3x3) NFL Narrow Flood (NEMA 4x4) MFL Medium Flood (NEMA 5x5) WFL Wide Flood (NEMA 6x6) 7X6 (NEMA 7x6) A33 Asymmetric 33 Flood (NEMA 6x5) RMF Rectangular Medium Flood (NEMA 7x4) RNF Rectangular Narrow Flood (NEMA 7x5)	SFC Slip Fitter Mount with Cord (fits on 2-3/8" to 3" O.D. tenon, 6' or 1.83m cord exits luminaire) SLF Slip Fitter Mount (fits on 2-3/8" to 3" O.D. tenon, wires through slip fitter) YOK Yoke Mount (6' or 1.83m cord exits luminaire)	120 120V 208 208V 240 240V 277 277V 347 347V 480 480V UNV 120-277V HVU 347-480V

Options						Finish	
Dimming controls ¹	Fusing	Surge Protection	Hardware Options	Other Options			
none leave blank (0-10V dimming driver standard) DALI ^{1,2,3} Digitally Addressable Lighting Interface driver DLEA ^{1,4,5} Dimming Leads Externally Accessible (for controls by others) FAWS ^{1,4} Field Adjustable Wattage Selector	none leave blank FS1 ⁷ Single Fuse (120V, 277V, or 347V) FS2 ⁷ Double Fuse (208V, 240V, or 480V) FS3 ^{7,10} Canadian Double Pole Fuse (208V, 240V, or 480V)	blank Surge Protector 10kV / 10kA (standard) SP2 Surge Protector 20kV / 10kA (option)	blank Captive screws TOL Tool-less entry latches VPA Vandal Proof Access (bit included with luminaire)	blank Terminal Block, Service Tag, and Wiring Cover (standard) API Factory-installed ANSI C136.15-2015 compliant label C## ⁹ Cord length specified by customer for SFC or YOK (put length in feet in place of "##" - example: C10 for 10' cord, must be ordered same time as luminaire - factory installed) (6' cord standard) PCB ^{2,5,6,7} Photocontrol Button TT7 ^{5,6,8} Tool-less NEMA Twist-lock 7-pin receptacle BAC ^{10,11} Meets the requirements of the Buy American Act of 1933 (BAA)	BK Black BZ Bronze MG Medium Gray OC ⁹ Optional Color (specify optional color or RAL, contact factory) SC ⁹ Special Color (must supply color chip, requires factory quote) MP ⁹ Marine Grade paint - must also specify one of the finish colors from list above [Ex: BK-MP] (requires factory quote)		

- Choose only 1 Dimming Controls option: either DALI or DLEA or FAWS.
- Not available with 347V, 480V, or HVU.
- Your specific required DALI profiles will be programmed at the factory. Contact factory for details. Also contact factory if +50C ambient with DALI is required.
- 0-10V dimming driver standard.
- Luminaire has 0-10V dimming wires exiting the luminaire for dimming controls by others. DLEA not available with PCB or TT7 - choose only 1 of the three options.
- Choose either PCB or TT7 option.
- Must specify applicable specific input voltage, not available with UNV or HVU.
- Use of photoelectric cell (by others) or shorting cap (by others) is required to ensure proper illumination.
- Must contact factory prior to ordering - these items are ETO Specials.
- Extended lead times apply. Contact factory for details.
- Failure to properly select the "BAC" suffix could result in you receiving product that is not BAA compliant

product with no recourse for an RMA or refund. This BAC designation hereunder does not address (i) the applicability of, or availability of a waiver under, the Trade Agreements Act, or (ii) the "Buy America" domestic content requirements imposed on states, localities, and other non-federal entities as a condition of receiving funds administered by the Department of Transportation or other federal agencies.

Connected lighting

Interact City connector node provides the plug and play wireless communications technology to connect your floodlight to the Interact City lighting management system.



Accessory Ordering Code	Description
LLC	Interact City cellular technology connector node

Contact Signify for additional support when connected lighting or additional services are desired.
 For more details visit: <https://www.interact-lighting.com/en-us/what-is-possible/interact-city>



FLDS DuraForm

Small floodlight

Accessories ¹³

(ordered separately, field installed - mounting hardware included, uses dedicated mounting holes - do NOT remove lens)



FLDM-VSR-(F) Visor, top or bottom, painted same finish to match luminaire (specify finish at placeholder F, can not be used with GSH)

FLDM-GSH-(F) Glare Shield, left or right, painted same finish to match luminaire (specify finish at placeholder F, can not be used with VSR)

FLDM-WRG Wire Guard (nestable and can be used with either VSR or GSH)

**FLDS-VSR Visor
Top or Bottom**

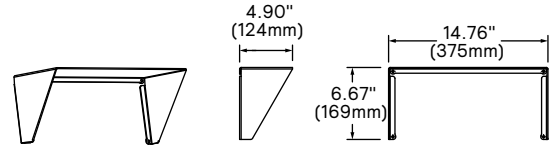

**FLDS-GSH Glare Shield
Left or Right**

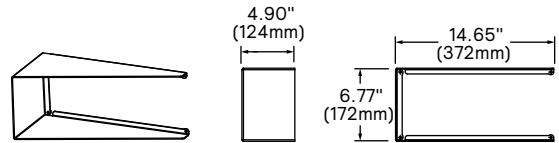

**FLDS-WRG Wire Guard
Nestable**

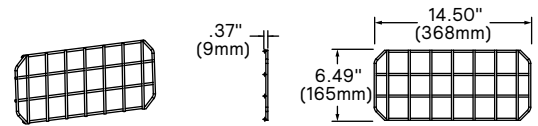

13. Consult Signify to confirm whether specific accessories are BAA-compliant.

Dimensions

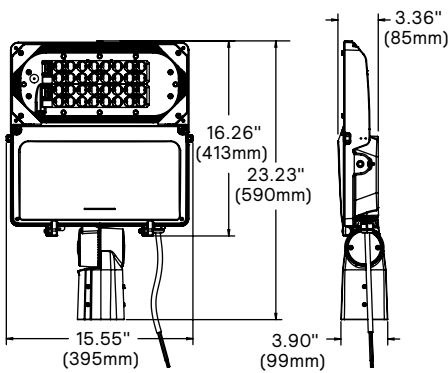

SFC

Luminaire weight: 19 lbs (8.6 kg)

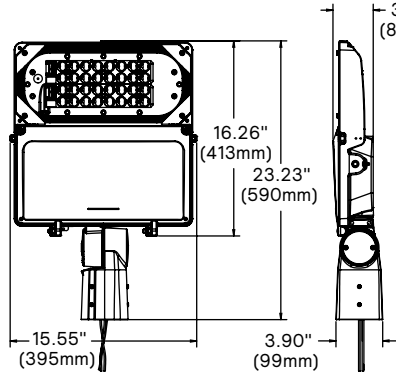

SLF

Luminaire weight: 19 lbs (8.6 kg)

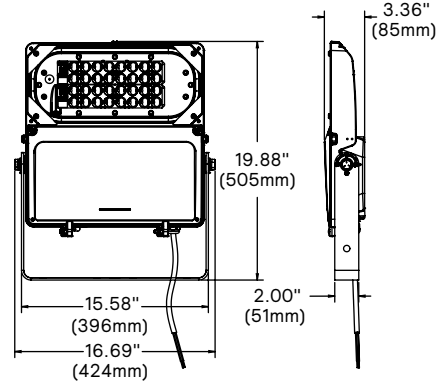

YOK

Luminaire weight: 20 lbs (9.1 kg)

**Slip Fitter mount
aiming diagram**

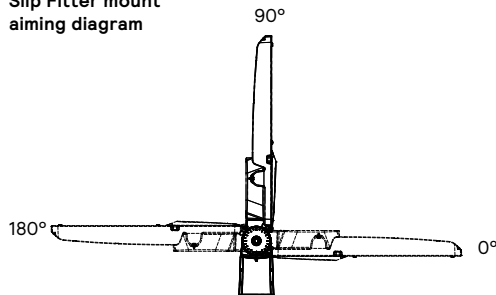

7-pin NEMA Twist Lock Receptacle option
Aiming limited to 0-90° per ANSI C136.10

**Yoke mount
detail**

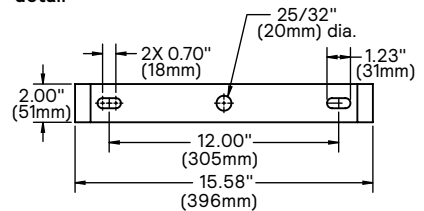

**Yoke mount
aiming diagram**

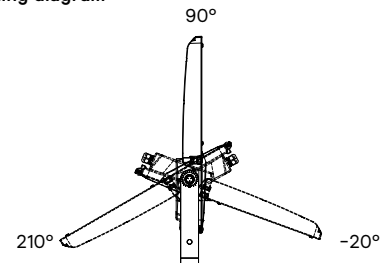

7-pin NEMA Twist Lock Receptacle option
Aiming limited to 0-90° per ANSI C136.10

Effective Projected Area (EPA-ft ²)			
Mounting	Single: 0° Aim	Single: 45° Aim	Single: 90° Aim
SFC or SLF	0.192	1.144	2.231
YOK	0.201	1.087	2.038

FLDS DuraForm

Small floodlight

DuraForm Accessories¹ (ordered separately, field installed, specify finish at placeholder F)

Mounting Accessories

For wall and pole brackets, bullhorns, etc. see <https://www.signify.com/en-us/products/outdoor-luminaires/poles-brackets/site-and-area-brackets/bull-horn-brackets#downloads> for details.

Exception: All UPS Upsweep - contact factory to confirm compatibility.

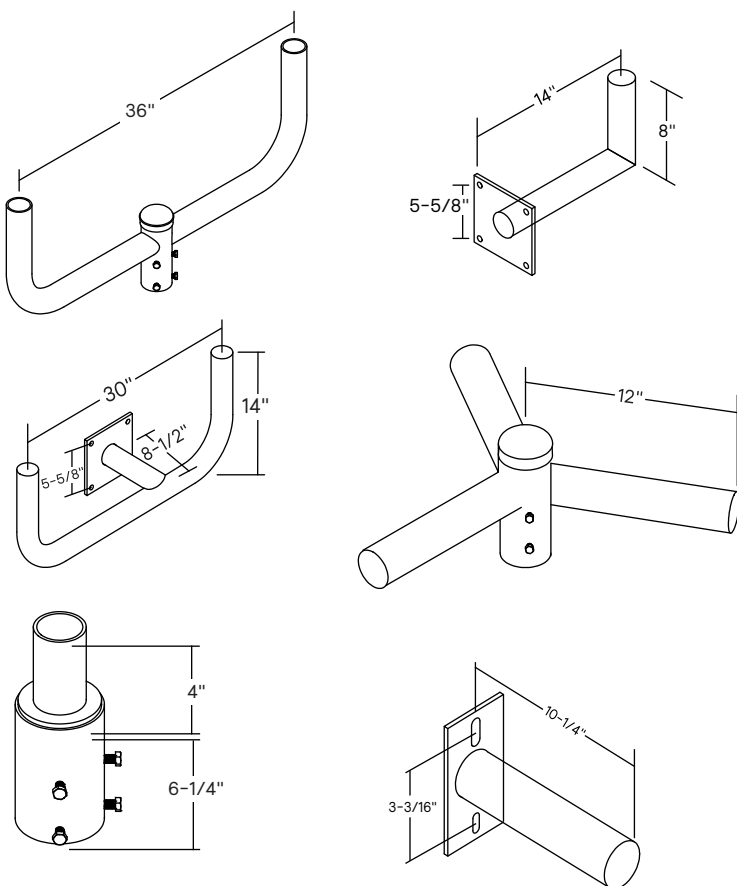

Examples shown are not to scale - see SBRKT spec sheet for all available brackets

1. Consult Signify to confirm whether specific accessories are BAA-compliant.

FLDS DuraForm

Small floodlight

Optical Distribution Diagrams

SPT Spot 12° Round (NEMA 2x2)

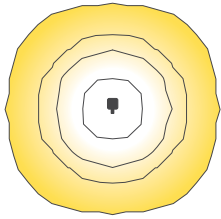

20' or 6.10m setback, 0° tilt

Applications include: flags, tighter spotlighting, accenting, taller columns, tighter scalloping, taller structures / monuments / statues, tallest trees.

RSP Rectangular Spot (NEMA 3x3)

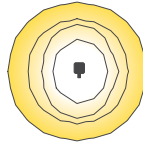

15' or 4.57m setback, 0° tilt

Applications include: flags, spotlighting, accenting, columns, scalloping, structures / monuments / statues, taller trees.

NFL Narrow Flood (NEMA 4x4)

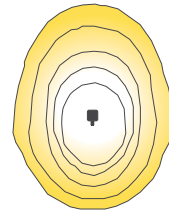

30' or 9.14m mounting height, 45° tilt

Applications include: area lighting, storage yards, transportation terminals, trailer lots, utility sub-stations, prison yards, ports, industrial sites, facades, structures / monuments / statues.

MFL Medium Flood (NEMA 5x5)

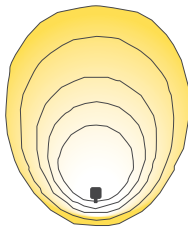

30' or 9.14m mounting height, 45° tilt

Applications include: area lighting, storage yards, transportation terminals, trailer lots, utility sub-stations, prison yards, ports, industrial sites, fence perimeters and borders, facades, structures / monuments / statues.

WFL Wide Flood (NEMA 6x6)

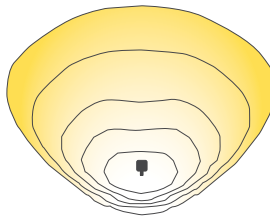

30' or 9.14m mounting height, 45° tilt

Applications include: area lighting, storage yards, transportation terminals, trailer lots, utility sub-stations, prison yards, ports, industrial sites, fence perimeters and borders, large facades.

7x6 (NEMA 7x6)

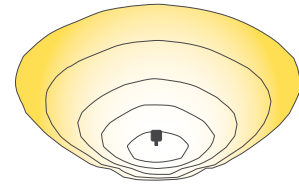

30' or 9.14m mounting height, 45° tilt

Applications include: area lighting, utility sub-stations, fence perimeters and borders, large and taller facades, wall grazing, signs (especially larger and taller ones).

A33 Asymmetric 33° Flood (NEMA 6x5)

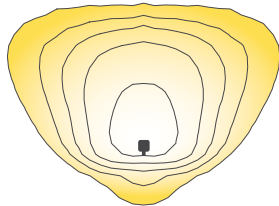

30' or 9.14m mounting height, 30° tilt

Applications include: area lighting, storage yards, transportation terminals, utility sub-stations, large facades, wall washing, large structures / monuments / statues, trees with large canopies.

RMF Rectangular Medium Flood (NEMA 7x4)

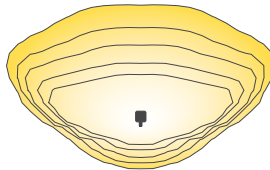

10' or 3.05m setback, 30° tilt

Applications include: building entrances and exits, security lighting, checkpoints and inspection stations, signs, ornamental trees and shrubs

RNF Rectangular Narrow Flood (NEMA 7x5)

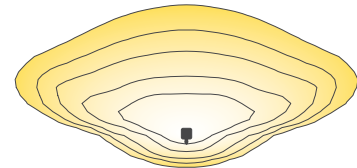

15' or 4.57m setback, 45° tilt

Applications include: facades, wall grazing, signs (especially larger and more rectangular)

Additional drawings

7-pin Twist Lock Receptacle Option

Aiming limited to 0-90° per ANSI C136.10
(NOTE: available on ALL mountings - SFC shown for illustrative purposes only)

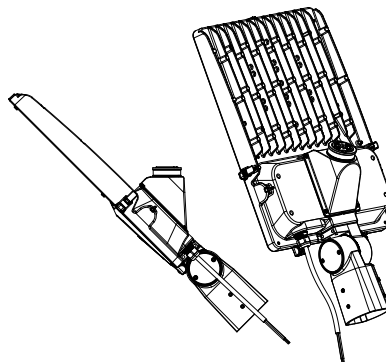

FLDS DuraForm

Small floodlight

LED Wattage and Lumen Values - 3000K

Ordering Code	Color Temp.	Average System Watts	Wattage Label*	SPT		NFL		MFL		WFL		7x6	
				Lumen Output	Efficacy (LPW)	Lumen Output	Efficacy (LPW)	Lumen Output	Efficacy (LPW)	Lumen Output	Efficacy (LPW)	Lumen Output	Efficacy (LPW)
FLDS-A01-730	3000	29	30	3,469	120	3,296	114	3,436	119	3,435	119	3,341	116
FLDS-A02-730	3000	43	40	4,939	115	4,693	109	4,893	114	4,892	114	4,757	111
FLDS-A03-730	3000	56	60	6,169	109	5,862	104	6,110	108	6,109	108	5,941	105
FLDS-A04-730	3000	53	50	6,805	129	6,466	123	6,741	128	6,740	128	6,555	125
FLDS-A05-730	3000	82	80	9,846	120	9,356	114	9,753	119	9,751	119	9,483	115
FLDS-A06-730	3000	109	110	12,217	112	11,608	106	12,101	111	12,099	111	11,767	108

LED Wattage and Lumen Values - 4000K & 5000K

Ordering Code	Color Temp.	Average System Watts	Wattage Label*	SPT		NFL		MFL		WFL		7x6	
				Lumen Output	Efficacy (LPW)	Lumen Output	Efficacy (LPW)	Lumen Output	Efficacy (LPW)	Lumen Output	Efficacy (LPW)	Lumen Output	Efficacy (LPW)
FLDS-A01-740 and -750	4000 Xand 5000	29	30	3,798	131	3,609	125	3,762	130	3,761	130	3,658	127
FLDS-A02-740 and -750	4000 and 5000	43	40	5,400	126	5,131	120	5,349	125	5,348	125	5,201	121
FLDS-A03-740 and -750	4000 and 5000	56	60	6,751	120	6,414	114	6,687	119	6,686	119	6,502	115
FLDS-A04-740 and -750	4000 and 5000	53	50	7,442	141	7,071	134	7,372	140	7,370	140	7,168	136
FLDS-A05-740 and -750	4000 and 5000	82	80	10,768	131	10,232	124	10,666	130	10,664	130	10,371	126
FLDS-A06-740 and -750	4000 and 5000	109	110	13,359	122	12,693	116	13,232	121	13,230	121	12,866	118

LED Wattage and Lumen Values - 3000K

Ordering Code	Color Temp.	Average System Watts	Wattage Label*	RSP		RMF		RNF		A33	
				Lumen Output	Efficacy (LPW)	Lumen Output	Efficacy (LPW)	Lumen Output	Efficacy (LPW)	Lumen Output	Efficacy (LPW)
FLDS-A01-730	3000	29	30	3,137	109	3,128	108	3,179	110	3,219	111
FLDS-A02-730	3000	43	40	4,465	104	4,453	104	4,525	105	4,581	107
FLDS-A03-730	3000	56	60	5,575	99	5,560	99	5,649	100	5,720	101
FLDS-A04-730	3000	53	50	6,151	117	6,134	117	6,233	118	6,311	120
FLDS-A05-730	3000	82	80	8,902	108	8,878	108	9,021	110	9,133	111
FLDS-A06-730	3000	109	110	11,044	101	11,014	101	11,191	102	11,331	104

LED Wattage and Lumen Values - 4000K & 5000K

Ordering Code	Color Temp.	Average System Watts	Wattage Label*	RSP		RMF		RNF		A33	
				Lumen Output	Efficacy (LPW)	Lumen Output	Efficacy (LPW)	Lumen Output	Efficacy (LPW)	Lumen Output	Efficacy (LPW)
FLDS-A01-740 and -750	4000 and 5000	29	30	3,429	119	3,419	118	3,475	120	3,518	122
FLDS-A02-740 and -750	4000 and 5000	43	40	4,880	114	4,867	113	4,946	115	5,007	117
FLDS-A03-740 and -750	4000 and 5000	56	60	6,093	108	6,077	108	6,174	109	6,252	111
FLDS-A04-740 and -750	4000 and 5000	53	50	6,723	128	6,704	127	6,813	130	6,898	131
FLDS-A05-740 and -750	4000 and 5000	82	80	9,730	118	9,704	118	9,860	120	9,982	121
FLDS-A06-740 and -750	4000 and 5000	109	110	12,071	110	12,038	110	12,232	112	12,385	113

Values from photometric tests performed in accordance with IESNA LM-79 and are representative of the configurations shown. Actual performance may vary due to installation and environmental variables, LED and driver tolerances, and field measurement considerations. It is highly recommended to confirm performance with a photometric layout.

NOTE: Some data may be scaled based on tests of similar (but not identical) luminaires. Contact factory for configurations not shown. IES

files available with VSR Visor or GSH Glare Shield Accessories - see website.

*Wattage Label per ANSI C136.15-2015. Consult factory for other labelling needs.

Field Adjustable Wattage Selector (FAWS) Multiplier Chart

FAWS Position	Typical Delivered Lumens Multiplier	Typical System Wattage Multiplier
1	0.31	0.28
2	0.53	0.50
3	0.62	0.58
4	0.70	0.67
5	0.78	0.75
6	0.83	0.81
7	0.89	0.87
8	0.92	0.91
9	0.96	0.95
10	1.00	1.00

Note: Actual performance may vary due to LED and driver tolerances.

Predicted Lumen Depreciation Data

Ambient Temperature °C	Drive current	Calculated L70 Hours	L70 per TM-21	Lumen Maintenance % at 60,000 hrs
25°C	up to 1050 mA	>100,000 hours	>36,000 hours	>99%

Predicted performance derived from LED manufacturer's data and engineering design estimates, based on IESNA LM-80 methodology. Actual experience may vary due to field application conditions. L70 is the predicted time when LED performance depreciates to 70% of initial lumen output. Calculated per IESNA TM21-11. Published L70 hours limited to 6 times actual LED test hours

FLDS DuraForm

Small floodlight

Specifications

Housing and Door

Made of low copper die cast Aluminum alloy (A360) for high resistance to corrosion. A hinged removable door opens to provide access to electronic components and to a terminal block. Door is secured to prevent accidental dropping or disengagement. Captive flanged hex head screws with slotted drive provide access to electrical components and are compatible with 1/4" flat blade screwdriver.

Mounting

Up tilt aiming and down tilt aiming possible with all of the mounting options. Top edge of casting includes aiming sight for daytime aiming (see instructions).

cULus Listed as suitable for mounting within 4' or 1.2m of the ground.

SFC: Adjustable Slip Fitter with 6' (1.83m) of AWG 16-3 SEOW cord (or AWG 16-5 if DLEA external control options are selected) exiting the luminaire through IP66 rated cord seal. Customer-specified length or different cord type available - contact factory. Slip Fitter made of low copper die cast Aluminum alloy (A360) for high resistance to corrosion, adjustable knuckle has 5 degree aiming increments with integral interlocking teeth and bolt to secure aiming in place, integral cast-in aiming marks. Fits on a range of tenons from 2-3/8" to 3" (60.3mm to 76.2mm) O.D.

SLF: Same Adjustable Slip Fitter as SFC but with AWG 16-3 wires (or AWG 16-5 if DLEA external control options are selected) exiting through the Slip Fitter. Integral splice compartment for field wiring with cULus Wet Location rated access cover with seal around entire perimeter.

YOK: Adjustable Yoke with 6' (1.83m) of AWG 16-3 SEOW cord (or AWG 16-5 if DLEA external control options are selected) exiting the luminaire through IP66 rated cord seal. Customer-specified length or different cord type available - contact factory. Yoke made of high strength steel, galvanized and painted for high resistance to corrosion, fully adjustable (no minimum aiming increments) with bolts to secure aiming in place, integral aiming marks.

IP Rating

IP66 rated luminaire in all aiming positions including up tilt aiming per ANSI C136.37 with seal around entire perimeter of the lens and seal around entire perimeter of the electrical / driver compartment.

Light Engine

Composed of 5 main components: Heat Sink, Lens, LED Module, Optical System, Driver. Electrical components are RoHS compliant. LEDs tested by ISO 17025 2005 accredited lab in accordance with IESNA LM-80 guidelines in compliance with EPA ENERGY STAR, extrapolations in accordance with IESNA TM-21. Metal core board ensures greater heat transfer and longer lifespan.

Heat Sink: Housing acts as heat sink, designed to ensure high efficacy and superior cooling by natural convection air flow always close to LEDs and driver(s) optimizing their efficiency and life. Product does not use any cooling device with moving parts (only passive cooling).

Lens: Made of soda-lime clear tempered glass flat lens, mechanically assembled and sealed onto the housing heat sink forming IP66 seal. NOTE: Lens is not designed to be removable (if removed impacts IP66 seal).

IK Rating: IK09 high impact resistance rating for luminaire lens.

LED Module: Composed of high performance white LEDs. Color temperature as per ANSI/NEMA bin 3000K nominal (3045K +/-175K) or 4000K nominal (3985K +/- 275K), both CRI 70 min. 75 Typical.

Optical System: Composed of high performance UV stabilized optical grade polymer refractor lenses to achieve desired distribution optimized to get maximum spacing, target lumens and a superior lighting uniformity. Performance shall be tested per LM-63, LM-79 and TM-15 (IESNA) certifying its photometric performance.

Driver: High power factor of 90% min. Electronic driver, operating range 50/60 Hz. Auto adjusting universal voltage input from 120 to 277 or 347 to 480 VAC rated for both application line to line or line to neutral, Class I, THD of 20% max. The current supplying the LEDs will be reduced by the driver if the driver experiences internal overheating as a protection to the LEDs and the electrical components. Output is protected from short circuits, voltage overload and current overload. Automatic recovery after correction. Standard built in driver surge protection of 2.5kV (min). Driver enables setting LED drive current to meet your specific total wattage consumption, lumen output and/or efficacy needs - ETO Specials, contact factory.

Integrated Features

Please note that these integrated features always come with this luminaire standard at no additional cost.

0-10V dimming driver included as standard, dimming leads pre-wired to Dimming Controls option except when DLEA external controls options are selected.

SP1: Surge protection device tested in accordance with ANSI/IEEE C62.45 per ANSI/IEEE C62.41.2 Scenario I Category C High Exposure 10kV/10kA waveforms for Line-Ground, Line-Neutral and Neutral-Ground. Enhanced surge protection device SP2 20kV/10kA available as an option. Surge protection device wired in parallel so that if it fails open the luminaire will remain lit/ powered on.

Service Tag: Each individual luminaire is uniquely identifiable, thanks to the Service tag application. With a simple scan of a QR code you gain instant access to the luminaire configuration, making installation and maintenance operations faster and easier, no matter what stage of the luminaire's lifetime. Just download the app and register your product right away.

For more details visit: philips.com/servicetag

Terminal Block: 3-position. Accepts wires from #2AWG to #14AWG, rated 600V, 85A.

Wiring Cover: Cosmetic cover over LED board wiring. Painted same finish to match luminaire.

Controls Options

Please note that other controls can be integrated as ETO Specials - contact factory.

DALI: Pre-set driver compatible with the DALI Digitally Addressable Lighting Interface control system.

DLEA: 0-10V dimming driver's dimming wires are externally accessible for connecting dimming controls by others.

FAWS: Field Adjustable Wattage Selector, pre-set to the highest position, can be easily switched in the field to the required position. This reduces total luminaire wattage consumption and reduces the light level - see the FAWS multiplier chart for more details.

Note: It is not recommended to use FAWS with other dimming or controls; if you do, set the switch to position 10 (maximum output) to enable the other dimming or controls. Switching FAWS to any position other than 10 will disable the other dimming or controls.

Connected Lighting

Interact City connector node provides the plug and play wireless communications technology to connect your floodlight to the Interact City lighting management system. With Interact you can remotely manage, monitor and control all city lighting, from roads and streets, to parks and plazas, and bridges from one single system. Connected lighting enables capabilities including, accurate on/off switching, dimming control, fault reporting and integration with other systems to enable condition-based lighting. Interact provides you with a robust and scalable infrastructure to further reduce energy consumption, improve operations, and turn lighting into a connected network for your smart city journey.

For more details visit: <https://www.interact-lighting.com/en-us/what-is-possible/interact-city>

FLDS DuraForm

Small floodlight

Specifications (continued)

Luminaire Options

SP2: 20kV / 10kA surge protection device that provides extra protection beyond the standard SP1 10kV/10kA level. Surge protection device wired in parallel so that if it fails open the luminaire will remain lit/powerd on.

TT7*: Tool Less orientable twist-lock receptacle with 7 pins enabling dimming, can be used with an Interact City node, a twist-lock photoelectric cell or a shorting cap.

* Use of photoelectric cell or shorting cap is required to ensure proper illumination.

Note: Additional hardware will be required to utilize the additional 2 pins on this receptacle.

API: Factory Installed NEMA label, ANSI C136.15-2015 compliant, identifies LED source and wattage, affixed to luminaire at factory. Consult factory for other labeling needs.

FS1: Fusing, single (120, 277 or 347VAC) installed in electrical compartment

FS2: Fusing, double (208, 240 or 480VAC) installed in electrical compartment

FS3: Fusing, Canadian Double Pole (208, 240 or 480VAC) installed in electrical compartment.

TOL: Tool Free access 316 stainless steel latches provide a high resistance to corrosion. Latches operable while wearing protective electrical gloves.

VPA: Vandal Proof hardware to prevent access to internal components, 316 stainless steel, complete with Ceramic primer seal to reduce seizing of the parts, also offers a high resistance to corrosion. Bit included with luminaire.

PCB: Photocell Button (a.k.a. button photoeye).

Luminaire Useful Life

Refer to IES files for energy consumption and delivered lumens for each option. Based on ISTMT in situ thermal testing in accordance with UL1598 and UL8750, exclusive Signify System Reliability Tool, Advance driver data and LED manufacturer LM-80/TM-21 data, expected to reach 100,000 + hours with L_{70} lumen maintenance @ 25°C. Luminaire Useful Life accounts for LED lumen maintenance AND all of these additional factors including: LED color shift, LED life, driver life, PCB substrate, solder joints, on/off cycles, burning hours and corrosion.

Wiring

#2-#14 AWG wires from the primary circuit, located inside the housing. Due to the inrush current that occurs with electronic drivers, recommend using a time-delay or slow blow fuse to avoid unwanted fuse blowing (false tripping) that can occur with normal or fast acting fuses.

Hardware and Seals

All exposed hardware shall be high-grade 316 stainless steel and ceramic coated for superior corrosion resistance and to prevent galvanic corrosion, and, shall be captive. All seals and sealing devices are made and/or lined with EPDM and/or silicone and/or rubber.

Finish

Color in accordance with the AAMA 2603 standard. Application of polyester powder coat paint (4 mils/100 microns) with ± 1 mils/24 microns of tolerance. The Thermosetting resins provides a discoloration resistant finish in accordance with the ASTM D2244 standard, as well as luster retention in keeping with the ASTM D523 standard and humidity proof in accordance with the ASTM D2247 standard. The standard finishes achieve a minimum scribe rating of 8 per ASTM D1654 after a minimum of 5000 hours salt spray in accordance with testing performed per ASTM B117 standard.

When Marine Grade paint option is selected, an additional step of anodizing castings is done prior to applying the MG paint. This increases corrosion resistance even further and results in a higher minimum scribe rating of 10 after a minimum of 5000 hours salt spray.

LED Products Manufacturing Standard

The electronic components sensitive to electrostatic discharge (ESD) such as light emitting diodes (LEDs) are assembled in compliance with IEC61340-5-1 and ANSI/ESD S20.20 standards so as to eliminate ESD events that could decrease the useful life of the product.

Vibration Resistance

Luminaire meets the ANSI C136.31-2018 specifications, tested by independent lab over 100,000 cycles in all three axes: Bridge/Overpass for both Slip Fitters and for Yoke.

Certifications and Compliance

cULus Listed for Canada and USA, per UL1598 and UL8750, including suitable for mounting within 4' or 1.2m of the ground. Configurations are DesignLights Consortium qualified, consult DLC QPL Qualified Products List for more details. Luminaire complies with or exceeds the following ANSI C136 standards: .2, .3, .10, .15, .21, .22, .24, .25, .31, .32, .37, .41. Entire luminaire is rated and cULus Elevated Ambient Listed for operation in ambient temperature of -40°C (-40°F) up to +50°C (+122°F) - contact factory if +50C ambient with DALI is required. Controls options enable compliance with Outdoor lighting energy codes including ASHRAE 90.1, California Title 24, and IECC.

Limited Warranty

10-year limited warranty.

See signify.com/warranties for details and restrictions.

