



Gardco SoftView LED parking garage luminaires feature edge lit comfort optics technology, providing uniform indirect illumination that minimizes glare and creates a welcoming environment. Luminaires come standard with 80CRI for improved visibility and an uplight feature that fosters a sense of openness and security by reducing the cave effect. With up to 18,000 lumens, four optical distributions, and five mounting options, SoftView offers a customizable solution for your garage and low/high bay lighting needs. Brighten your space with SoftView and appreciate long-lasting performance, peace of mind, and optimal user experience.

Project: _____
 Location: _____
 Cat.No: _____
 Type: _____
 Lamps: _____ Qty: _____
 Notes: _____

Ordering guide

Example: SVPG-A06-840-5RD-SUR-UNV-BLBT-L3-SP2-MG

Luminaire	Configuration (nom. lumens)	Color Temp.	Distribution	Mounting	Voltage
SVPG					
SVPG SoftView	A01 2,400 A06 6,500	830 80CRI, 3000K	T1R Type 1 Rectangular	SUR Surface Mount / indirect pendant Mount, Normal vibration rated (pendant and junction box by others)	120 120V
Parking	A02 4,100 A07 8,200		T3A Type 3 Asymmetric	Surface Mount, Bridge / Overpass vibration rated	208 208V
Garage	A03 6,000 A08 10,000	840 80CRI, 4000K	5RD Type 5 Round	SBO Direct Pendant Mount, Bridge / Overpass vibration rated (pendant and junction box by others)	240 240V
	A04 8,000 A09 11,400		5CD Type 5 Concentrated Downlight	PEN Trunnion Mount (must also order separate line item TM mounting kit, see Accessories)	277 277V
	A05 9,500 A10 13,400	750¹⁰ 70CRI, 5000K		TRN^{2,13} Wall Mount (must also order separate line item WM mounting kit, see Accessories)	347¹¹ 347V
	A11 14,800			WAL¹⁵	480¹¹ 480V
					UNV Universal 120-277V
					HVU¹¹ High Voltage Universal 347-480V

Options		Electrical	Emergency	Other options	Finish
Dimming Controls (only one may be selected)	Sensing⁹ (only one may be selected)	Fusing⁷	none Leave blank	BAC⁹ Meets the requirements of the Buy American Act of 1933 (BAA)	BZ Bronze
0-10V⁸		none Leave blank	EM^{2,6,8,12} UL 924 Listed Emergency Battery Pack (0°C to +40°C / 32°F to +104°F)		MG Medium Gray
none Leave blank (0-10V dimming driver standard)	none Leave blank	FS1 Single Fuse (120V, 277V, or 347V)	EC^{5,8,12} UL 924 Listed Emergency Battery Pack, Cold Rated (-20°C to +40°C / -4°F to +104°F)		WH White
DLEA^{2,4} Dimming Leads Externally Accessible (controls by others)		FS2 Double Fuse (208V, 240V, or 480V)	ER100¹³ UL924 Listed Emergency relay to bypass WIAP wireless dimming sensor, integral		OC⁹ Optional color (specify optional color or RAL, contact factory)
BL20^{3,11} Bi-level set at 20% dimming	MW^{5,11} Microwave Sensor	FS3 Double Fuse Canadian double pole (208V, 240V, or 480V)			SC⁹ Special Color (must supply color chip, requires factory quote)
BLBT^{3,8,11} Bi-level with motion sensor, Bluetooth programming, set at 20% dimming	L2 PIR Sensor, #2 lens L3 PIR Sensor, #3 lens L7 PIR Sensor, #7 lens (All sensing is factory customizable, contact factory ¹¹)	Surge Protection			
DAL^{6,11,12}		blank SP1 Surge Protector 10kV / 10kA (standard)			
SRDR¹⁴ SR Driver connected to SR Receptacle (Zhaga 4-pin)	none Leave blank	SP2 Surge Protector 20kV / 10kA (option)			
WIAP^{3,13,15} Wireless Interact (includes SR driver and SR receptacle)	LW Low (7'-15' mounting height) sensor, white color housing HW High (15'-40' mounting height) sensor, white color housing				

- T3A not available with A06, A07, A08, A09, A10 or A11 configurations due to thermal and fit restrictions.
- TRN not available with combination of both DLEA and EM options due to fit restrictions; TRN is available with each individually (either DLEA or EM).
- BL20 must be combined with MW Microwave Sensor. BLBT must be combined with Sensing option L2, L3 or L7. WIAP must be combined with Sensing option LW or HW. Choose only 1: either BL20-MW or BLBT-L# or WIAP-xW.
- DLEA luminaire has 0-10V dimming wires exiting the luminaire for dimming controls by others.
- MW available with 120V, 208V, 240V, 277V, UNV or 347V only.
- Available with 120V, 208V, 240V, 277V or UNV only.
- Must specify input voltage. UNV and HVU not valid.
- Choose either Emergency option EM or EC cold. EM only available with A01, A02, A03 or A06 and EC cold only available with A01, A02, A03, or A06 due to thermal restrictions. EC cold not available with DLEA or BL20-MW or BLBT-L# due to fit restrictions; EM is available with DLEA or BL20-MW or BLBT-L# (does fit).
- Must contact factory prior to ordering.
- Extended lead times apply. Contact factory for details.
- A09, A10, A11 each have 2 drivers therefore due to fit restrictions not available with 347V, 480V, HVU, SRDR, BL20-MW, BLBT, or WIAP.
- SRDR or WIAP not available with Emergency options EM or EC cold due to thermal and fit restrictions.
- ER100 suitable for use in 40C ambient with A01, A02, A03, A04, A06 or A07 (72W max.); suitable for use in 35C ambient with A05 or A08 (90W max.); not available above 90W; no A09, A10 or A11. ER100 must be installed in conjunction with a UL 1008 device (such as a transfer switch at the electrical panel) and only for use with Wireless Interact dimming sensor (WIAP-xW). ER100 is 120V-277V. For PI Detection with TRN Trunnion, must be wired at factory; contact factory for details
- When ordering SRDR, controller (by others) to be plugged into socket must be SR compatible (see Specifications for more details). Consult factory for lead time.
- CAUTION: It is advised not to configure WIAP with WAL due to potential adverse impacts on Daylight Dependent Regulation (DDR) functionality (which supports photocontrol and daylight harvesting).



SVPG SoftView

Garage & Canopy luminaire

Accessories (ordered separately, field installed)

ES	External House Side Shield (designed for use with Type 3, reduces light output by approx. 15% on average)	SVPG-G2-TM-(F)	Trunnion Mount kit (can ONLY use when TRN Trunnion Mount product is ordered)	BXC	Bird excluding coil (fits on all mounting options) (negligible upright impact)
WG	Wire Guard	SVPG-G2-WM-(F)	Wall Mount kit (can ONLY use when WAL Wall Mount product is ordered)	BXK	Bird excluding spikes (fits on Pendant, Trunnion, and Wall mounts only) (negligible upright impact)
IRT9015	Handheld remote for grouping and configuration of Wireless Interact WIAP (at least 1 required per site or use the Interact Pro app).			BXS	Bird excluding shroud (fits on Pendant mount only) (negligible upright impact)

(F) = specify finish

Controls Matrix

Dimming Controls & Sensing (where applicable)	Fusing: FS1, FS2, or FS3	Surge Protection: standard SP1 or optional SP2	Emergency: none or EM ^{2, 8, 12}	Emergency: or EC ^{8, 12}
Only choose one of the dimming options³				
none	yes	yes	yes	yes
BL20 ⁵ -MW	yes	yes	yes	no
BLBT ⁵ -L2	yes	yes	yes	no
BLBT ⁵ -L3	yes	yes	yes	no
BLBT ⁵ -L7	yes	yes	yes	no
DLEA ^{2, 8}	yes	yes	yes - except DLEA and EM NOT available with TRN ² Trunnion	no
SRDR	yes	yes	yes	no
WIAP ¹² -LW	yes	yes	no	no
WIAP ¹² -HW	yes	yes	no	no

Compatibility Matrix

Configuration	Distribution		Dimming Controls & Sensing (where appl.)			Emergency		
	T1R or 5RD or 5CD	T3A ¹	Only choose one of the dimming options ³			EM ⁸	or EC ⁸	ER100 ¹³ (only for use with WIAP ¹¹ -xW)
			none or DLEA	BL20 ¹¹ -MW or BLBT ¹¹ -L#	SRDR ¹¹ or WIAP ¹¹ -xW			
A01	yes	yes	yes	yes	yes	yes	yes	yes*
A02	yes	yes	yes	yes	yes	yes	yes	yes*
A03	yes	yes	yes	yes	yes	yes	yes	yes*
A04	yes	yes	yes	yes	yes	no	no	yes*
A05	yes	yes	yes	yes	yes	no	no	yes*
A06	yes	no	yes	yes	yes	yes	yes	yes*
A07	yes	no	yes	yes	yes	no	no	yes*
A08	yes	no	yes	yes	yes	no	no	yes*
A09	yes	no	yes	no	no	no	no	no
A10	yes	no	yes	no	no	no	no	no
A11	yes	no	yes	no	no	no	no	no

*NOTE: Please see Ordering guide footnote 13 for ER100 ambient temperature suitability with various lumen / wattage configurations A01-A08.

Compatible = "yes", NOT compatible = "no". Applicable footnote superscripts included to help cross-reference to Ordering guide.

SVPG SoftView

Garage & Canopy luminaire

LED wattage and lumen values

Ordering Code	Color Temperature	Average System Watts (W)	T1R			T3A			5RD			5CD		
			Lumen Output	BUG Rating	Efficacy (LPW)	Lumen Output	BUG Rating	Efficacy (LPW)	Lumen Output	BUG Rating	Efficacy (LPW)	Lumen Output	BUG Rating	Efficacy (LPW)
SVPG-A01-830	3000	21	1,884	B1-U3-G1	90	2,200	B1-U3-G1	105	2,227	B2-U2-G1	106	2,345	B1-U0-G1	112
SVPG-A02-830	3000	36	3,267	B2-U3-G2	91	3,816	B2-U3-G2	106	3,862	B2-U3-G1	107	4,068	B2-U0-G1	113
SVPG-A03-830	3000	52	4,716	B2-U3-G2	91	5,507	B2-U3-G2	106	5,574	B3-U3-G2	107	5,870	B3-U0-G2	113
SVPG-A04-830	3000	72	6,345	B3-U3-G3	88	7,409	B3-U3-G3	103	7,500	B3-U3-G2	104	7,899	B3-U0-G2	110
SVPG-A05-830	3000	90	7,596	B3-U3-G3	84	8,870	B3-U3-G3	99	8,979	B3-U3-G2	100	9,456	B3-U0-G2	105
SVPG-A06-830	3000	51	5,018	B3-U3-G3	98	-	-	-	5,575	B3-U3-G2	109	6,021	B3-U0-G2	117
SVPG-A07-830	3000	71	6,933	B3-U3-G3	98	-	-	-	7,704	B3-U3-G2	108	8,320	B3-U0-G2	117
SVPG-A08-830	3000	90	8,544	B3-U3-G3	95	-	-	-	9,493	B3-U3-G2	106	10,253	B3-U0-G2	114
SVPG-A09-830	3000	107	9,987	B3-U3-G3	94	-	-	-	11,097	B3-U3-G2	104	11,985	B3-U0-G2	113
SVPG-A10-830	3000	132	11,636	B3-U4-G3	88	-	-	-	12,929	B4-U3-G3	98	13,964	B3-U0-G3	106
SVPG-A11-830	3000	149	12,955	B3-U4-G3	87	-	-	-	14,395	B4-U3-G3	96	15,546	B4-U0-G3	104
SVPG-A01-840	4000	21	2,026	B1-U3-G1	97	2,366	B1-U3-G1	113	2,395	B2-U2-G1	114	2,522	B1-U0-G1	120
SVPG-A02-840	4000	36	3,513	B2-U3-G2	98	4,103	B2-U3-G2	114	4,153	B2-U3-G1	115	4,374	B2-U0-G1	122
SVPG-A03-840	4000	52	5,071	B2-U3-G2	98	5,921	B2-U3-G2	114	5,994	B3-U3-G2	115	6,312	B3-U0-G2	121
SVPG-A04-840	4000	72	6,823	B3-U3-G3	95	7,967	B3-U3-G3	111	8,065	B3-U3-G2	112	8,494	B3-U0-G2	118
SVPG-A05-840	4000	90	8,168	B3-U3-G3	91	9,538	B3-U3-G3	106	9,655	B3-U3-G2	107	10,168	B3-U0-G2	113
SVPG-A06-840	4000	51	5,396	B3-U3-G3	105	-	-	-	5,995	B3-U3-G2	117	6,475	B3-U0-G2	126
SVPG-A07-840	4000	71	7,455	B3-U3-G3	105	-	-	-	8,284	B3-U3-G2	116	8,946	B3-U0-G2	126
SVPG-A08-840	4000	90	9,187	B3-U3-G3	102	-	-	-	10,208	B3-U3-G2	114	11,025	B3-U0-G2	123
SVPG-A09-840	4000	107	10,739	B3-U3-G3	101	-	-	-	11,933	B3-U3-G2	112	12,887	B3-U0-G2	121
SVPG-A10-840	4000	132	12,512	B3-U4-G3	95	-	-	-	13,903	B4-U3-G3	105	15,015	B3-U0-G3	114
SVPG-A11-840	4000	149	13,930	B3-U4-G3	93	-	-	-	15,478	B4-U3-G3	104	16,716	B4-U0-G3	112
SVPG-A01-750	5000	21	2,188	B1-U3-G1	104	2,555	B1-U3-G1	122	2,587	B2-U2-G1	123	2,724	B1-U0-G1	130
SVPG-A02-750	5000	36	3,794	B2-U3-G2	105	4,431	B2-U3-G2	123	4,485	B2-U3-G1	125	4,724	B2-U0-G1	131
SVPG-A03-750	5000	52	5,477	B2-U3-G2	105	6,395	B2-U3-G2	123	6,474	B3-U3-G2	125	6,817	B3-U0-G2	131
SVPG-A04-750	5000	72	7,369	B3-U3-G3	102	8,604	B3-U3-G3	120	8,710	B3-U3-G2	121	9,174	B3-U0-G2	127
SVPG-A05-750	5000	90	8,821	B3-U3-G3	98	10,301	B3-U3-G3	115	10,427	B3-U3-G2	116	10,981	B3-U0-G2	122
SVPG-A06-750	5000	51	5,828	B3-U3-G3	112	-	-	-	6,475	B3-U3-G2	125	6,993	B3-U0-G2	135
SVPG-A07-750	5000	71	8,051	B3-U3-G3	112	-	-	-	8,946	B3-U3-G2	125	9,662	B3-U0-G2	135
SVPG-A08-750	5000	90	9,922	B3-U3-G3	110	-	-	-	11,025	B3-U3-G2	122	11,907	B3-U0-G2	131
SVPG-A09-750	5000	107	11,598	B3-U3-G3	108	-	-	-	12,887	B3-U3-G2	120	13,918	B3-U0-G2	129
SVPG-A10-750	5000	132	13,513	B3-U4-G3	101	-	-	-	15,015	B4-U3-G3	112	16,216	B3-U0-G3	121
SVPG-A11-750	5000	149	15,044	B3-U4-G3	100	-	-	-	16,716	B4-U3-G3	111	18,054	B4-U0-G3	120

Emergency mode

Ordering Code	Approximate average lumen output*
SVPG-A01 or A02 or A03, EM	2,400
SVPG-A01 or A02 or A03, EC cold rated	2,900
SVPG-A06, EM	2,600
SVPG-A06, EC cold rated	3,200

Values from photometric tests performed in accordance with IESNA LM-79 and are representative of the configurations shown. Actual performance may vary due to installation and environmental variables, LED and driver tolerances, and field measurement considerations. It is highly recommended to confirm performance with a photometric layout.

NOTE: Some data may be scaled based on tests of similar (but not identical) luminaires. Contact factory for configurations not shown.

* For emergency EM and EC options, published values are based on approximate averages across all CCTs and all distributions assuming 15 foot mounting height. It is highly recommended to confirm with a photometric layout that emergency performance meets your applicable ordinances.

SVPG SoftView

Garage & Canopy luminaire

Dimension drawings

Surface / Indirect Pendant mount

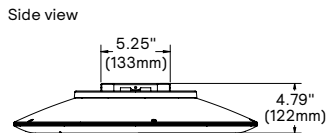
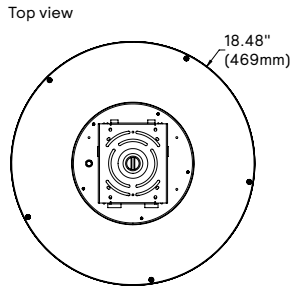

Trunnion mount

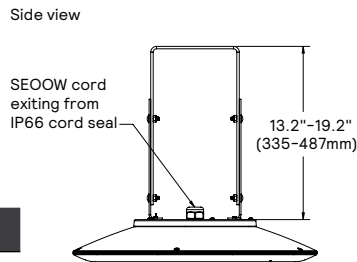
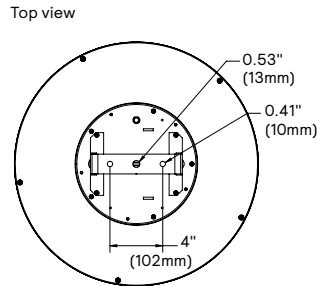

Direct Pendant mount

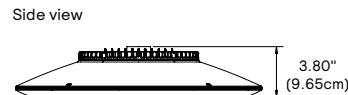
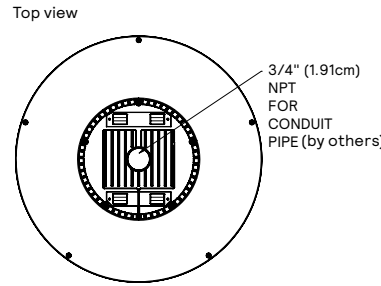

Wall mount

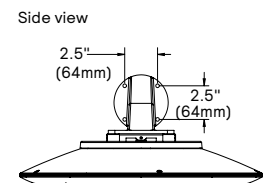
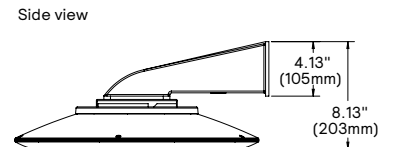
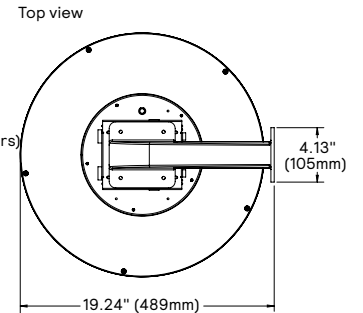

SoftView LED	Weight
A01-A05 Luminaire	9.1 lbs (4.1 Kg)
A06-A11 Luminaire	10.3 lbs (4.7 Kg)
Luminaire with EM	11.6 lbs (5.3 Kg)
Luminaire with EC	15.1 lbs (6.8 Kg)

Motion response controls

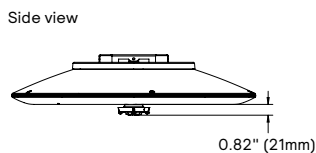
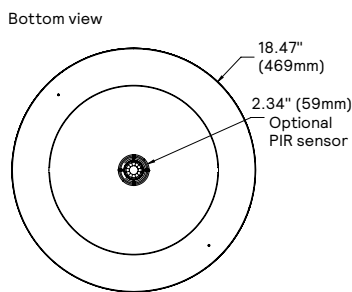

External house side shield

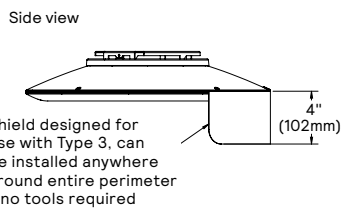
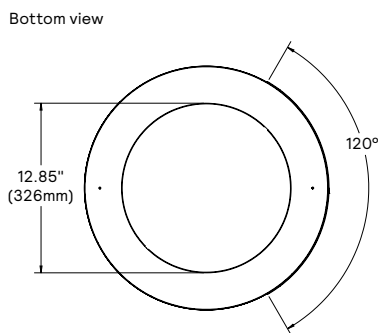

BXS Bird excluding shroud

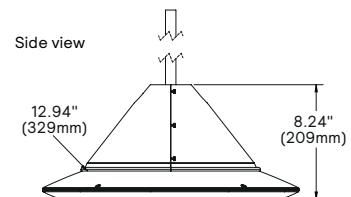
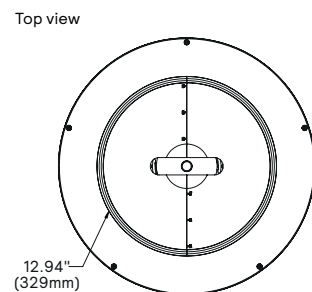

SVPG SoftView

Garage & Canopy luminaire

Specifications

Construction

Lower housing made of low copper die cast Aluminum alloy for high resistance to corrosion. Upper polycarbonate lens provides uplight, tapered shape of upper housing deters dirt accumulation, eases cleaning frequency, and deters birds from sitting or nesting. UV-resistant acrylic lower lens.

IP Rating

IP66 rated luminaire with seal around entire perimeter of the lens. All electrical components within entire perimeter of lens, also within IP66 seal. Includes breather element that equalizes pressure between luminaire interior and exterior environment and maintains it over time to prevent water entry and premature gasket failure.

IK Rating

IK10 high impact resistance rating for both the upper lens and the lower lens.

LED Thermal management

The luminaire design provides excellent thermal management critical to long LED, driver and system life. Natural convection air flow, product does not use any cooling device with moving parts (only passive cooling).

Light engine

Composed of mid power LEDs, uniformly spaced around entire perimeter of lens (symmetric distributions). Color temperatures per ANSI/NEMA bin Warm White 3000K nominal (3045 +/-175K) 80CRI, Neutral White 4000K nominal (3985 +/- 275K) 80CRI, or Cool White 5000K nominal (5029 +/- 283K) 70CRI (80CRI available - must contact factory prior to ordering. LEDs tested by ISO 17025 accredited lab in accordance with IESNA LM-80 guidelines, extrapolations in accordance with IESNA TM-21.

Optical system

Light guide plate composed of high performance optical grade PMMA (polymethyl methacrylate) acrylic. Edge-lit light guide technology allows for optimal light distribution without direct view of the LEDs, providing low-glare, uniform horizontal and vertical illumination with optimum visual comfort. Type 1R Rectangular, Type 3 Asymmetric, Type 5 Symmetrical and Concentrated Downlight (5CD) distributions available, designed for compliance to IES RP-8. Consider Type 1R for one luminaire per bay applications, ramps, and drive lanes leading up to or exiting parking stall decks; Type 3 for wall mount applications and perimeter mounted luminaires to throw light into parking garage away from property line (LEED compliance, property cut-off, avoid light trespass); Type 5 for general use in parking bays; Concentrated Downlight and/or higher lumen configurations when enhanced lighting is required for entries and exits, ramps, payment areas, lobbies and waiting areas, etc. and for security lighting per IES G-1. Uplight (up to 3%) provided with Type 1R, Type 3 and Type 5 to eliminate cave effect; for these distributions almost no uplight (<1%) available - must contact factory prior to ordering. Almost no uplight (<1%) provided standard with Type 5CD. More uplight available - must contact factory prior to ordering, this is an ETO Special. Performance tested per LM-63, LM-79 and TM-15 (IESNA) certifying its photometric performance.

Electrical

Constant current electronic driver. High power factor (0.9 minimum). 50/60 Hz. Low THD (20% maximum). Open/short circuit protection and voltage overload protection, automatic recovery after correction. Driver comes standard with 6KV on-board surge protection. Dimming driver standard. 0-10V dimming to minimum 10% power. RoHS compliant. Driver enables setting LED drive current to meet your specific total wattage consumption, lumen output and/or efficacy needs, contact factory.

Surge protector standard and tested in accordance with ANSI/IEEE C62.45 per ANSI/IEEE C62.41.2 Scenario I Category C High Exposure 10KV/10KA waveforms for Line-Ground, Line-Neutral and Neutral-Ground. Optional enhanced surge protector 20KV/10KA also available. Surge protector wired in parallel so that if it fails open the luminaire will remain lit/powerd on. When Emergency options **EM** or **EC** are chosen, two surge protectors provided for complete protection - one for unswitched hot line, one for switched hot line.

Due to the inrush current that occurs with electronic drivers, recommend using a time delay or slow blow fuse to avoid unnecessary and unwanted fuse blowing that can occur with fast acting fuses.

Mounting

SUR: Surface mount for Normal vibration rating. Stamped anodized aluminum upper housing with a die formed 16 ga. galvanized steel EZ-hang plate supplied for mounting to a recessed or surface-mounted 4" (10.16 cm) junction box (by others) - flush ceiling mount to a recessed junction box, or direct mount to a surface-mounted junction box. Integral hanger tabs on the plate support the luminaire during wiring. Single screw secures luminaire for quick and easy installation. Includes minimum 12" (30.48cm) wires that pass through IP66 rated grommet which seals around the wires. For indirect pendant mounting with Normal vibration rating, order Surface Mount (SUR) and mount to a wet location junction box (by others) which you then direct mount onto rigid pendant (by others).

SBO: Surface mount for higher Bridge / Overpass vibration rating. Die-cast aluminum upper housing with a supplied die formed 16 ga. galvanized steel EZ-hang plate with integral strengthening feet. Plate supplied for mounting to junction box (by others), integral hanger tabs on plate support luminaire during wiring. Single screw secures luminaire for quick and easy installation. Includes minimum 12" (30.48 cm) wires that pass through IP66 rated grommet which seals around the wires.

PEN: Direct pendant mount for higher Bridge / Overpass vibration rating. Die-cast aluminum upper housing includes integral 3/4" NPT tapped hole for direct mounting onto rigid 3/4" pendant (by others). Includes minimum 38" (96.52 cm) wires that pass through IP66 rated grommet which seals around the wires.

TRN: Mounts to a concrete ceiling with an anodized aluminum trunnion bracket assembly (order separate line item accessory, painted to match luminaire finish). Includes minimum 36" (91.44 cm) SEOW cord exiting luminaire through IP66 cord seal. The assembly permits (8) one inch (2.54 cm) incremental mounting height adjustments, ranging from 13 to 21 inches (33.02 to 53.34 cm).

WAL: Anchors directly on a wall with wall bracket assembly (order separate line item accessory, painted to match luminaire finish), includes minimum 12" (30.48cm) wires that pass through IP66 rated grommet which seals around the wires.

Control Options

Note: other controls can be integrated - contact factory.

DLEA: 0-10V dimming driver with dimming wires externally accessible for connecting dimming controls by others.

BLBT: Motion Response luminaires include a WattStopper passive infrared (PIR) motion sensor, standby power is 0.5 watts. Factory pre-programmed standard settings include a dimming level down to 20% and time delay of 10 minutes with no stand-by period. This means when no motion is detected for 10 minutes the sensor will dim the luminaire down to 20% of total lumen output. When motion is detected the luminaire returns to 100% full light output and will remain on full power for 10 minutes default prior to dimming back to low when no motion is detected. Other dimming levels, holding times and stand-by periods are possible by re-programming in the field via Bluetooth® using the WattStopper sensor configuration mobile app (available in iOS® or Android®); programming is also factory customizable, contact factory.

Motion Response includes light sensor feature called **Photocell On/Off** which is disabled by default. This feature can be enabled in the field using the same WattStopper sensor configuration mobile app - this allows for daylight harvesting supported through dimming. Motion sensor includes reading/measuring feature called **Sensor Level** that can be used to establish a baseline for daylight harvesting. See WattStopper sensor configuration mobile app User Guide for details (contact WattStopper for programming help as required).

with L2 #2 lens

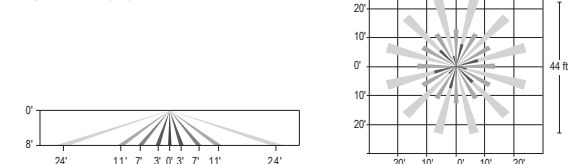

with L3 #3 lens

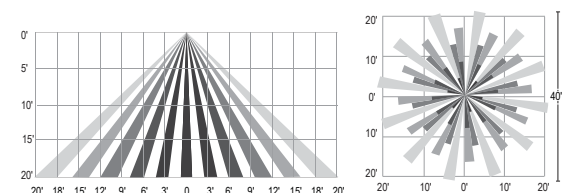

with L7 #7 lens

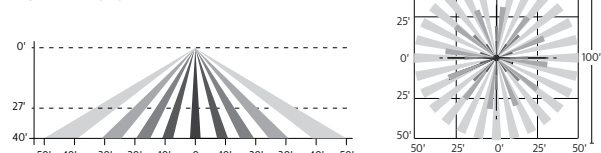

SVPG SoftView

Garage & Canopy luminaire

Specifications

Controls Options

BL20-MW: Motion response luminaires include a high frequency microwave sensor, 5.8GHz+/- 75MHz microwave ISM continuous wave band with 360° coverage area, <0.5 mW transmitting power and <1 W standby power. Microwave motion sensor designed to detect motion through the lower lens so it is hidden inside the luminaire without any protruding components. Sensor allows energy savings and meeting code requirements without compromising comfort and aesthetics. Factory pre-programmed standard settings include a dimming level down to 20% and time delay of 3 minutes with no stand-by period. This means when no motion is detected for 3 minutes the sensor will dim the luminaire down to 20% of total lumen output. When motion is detected the luminaire returns to 100% full light output and will remain on full power for 3 minutes default prior to dimming back to low when no motion is detected. Other dimming levels, holding times and stand-by periods are possible, contact factory. Microwave sensor's photocell is disabled since the sensor is embedded inside the luminaire (therefore daylight harvesting is not possible).

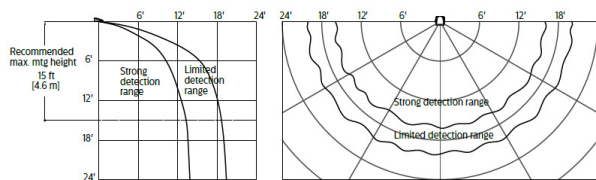

Sensor Ready SR Driver and Zhaga Socket (SRDR): Product equipped with Sensor Ready driver(s) connected to 4-pin Zhaga Book 18 compliant receptacle designed for sensor and other control system applications. Receptacle is rated IP66 assembly in a compact design that provides a sealed electrical interface and rated UV resistance, mounted on underside of the luminaire, protective dust cap included. When a controller not provided by Signify is used with Sensor Ready Zhaga socket connector, the controller must be certified to work with the Xitanium SR LED drivers as part of the SR certified program.

WIAP with LW or HW sensor: Scalable connected sensor with integral occupancy and daylight sensing, supports wireless mesh connectivity. Sensor works in the Foundation mode when configured without a gateway or in an Interact Advanced mode if a compatible gateway (can be added later) is used. Interact offers an App, a portal and a broad portfolio of Interact-ready Indoor and Outdoor luminaires, lamps and retrofit kits all working on the same system. Startup is implemented via Interact Pro App (available in iOS® or Android®) and Bluetooth® connectivity. The App provides flexibility to choose between a gateway or non gateway mode for setup. Setup with the gateway requires wired internet access to the gateway. Prepare project configuration steps remotely and use IRT9015 remote accessory (ordered separately) or the App on-site to identify and group devices together. WIAP includes SR driver and SR receptacle. Daylight harvesting supported through dimming - activated via the Interact App. Sensors IP66 rated.

Compatible with the following (ordered separately):

- Battery powered IP65 presence sensor OCC sensor IA CM IP65 WH
- Battery powered IP65 presence & daylight sensor OCC-DLsensor IA CM IP65 WH

CAUTION: It is advised not to use the WIAP sensor options in combination with the mounting option WAL Wall mount. Placing the sensor near a reflective surface, such as a wall, may adversely impact Daylight Dependent Regulation (DDR) functionality (which supports photocontrol and daylight harvesting).

For more details visit: <https://www.interact-lighting.com>

LW low sensor

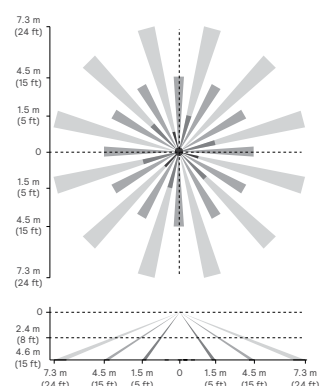

HW high sensor

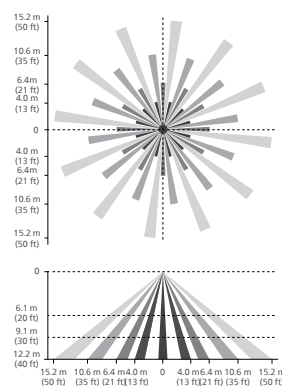

Note: The beam patterns shown are intended solely as a general guide and are not to scale. Sensing capabilities and coverage area depend on many factors including the size, speed and direction of travel of persons and vehicles; sensor mounting height; environmental and site conditions; etc.

ER100 (use with WIAP only): Optional internal emergency relay. When normal AC power is lost, relay bypasses WIAP wireless dimming sensor and forces luminaire to full light output.

Power Sensing (Factory default) - Recommended UL924 option requires unswitched power sense line, absence of voltage on the normal circuit triggers luminaire to 100% output.

Power Interruption Detection (Field option*) - Detects AC power interruption >30ms triggers 90 minute emergency mode with luminaire at 100% output, consult your local authority for UL924 applicability. *NOTE: For ER100 Power Interruption Detection when TRN Trunnion is also ordered - must contact factory prior to ordering; must be wired at the factory.

Emergency battery backup

Optional internal emergency battery pack immediately detects normal AC power loss then provides emergency light output for a minimum of 90 minutes when power is lost compliant with UL 924/CSA22.2 No. 141 and NFPA 101 Life Safety Code path of egress requirements. Integral so there is a consistent look between emergency and non-emergency luminaires, separate accessory box is not required. **EM** suitable for use in ambient temperature conditions from 0°C (+32°F) to +40°C (+104°F). **EC** suitable for use in ambient temperatures from -20°C (-4°F) to +40°C (+104°F). **EM** and **EC** are not available for use with **347V, 480V** or **HVU**. **EM** and **EC** always include surge protection for both the switched and unswitched lines to ensure complete protection.

Optical Distributions

Based on 10' mounting height

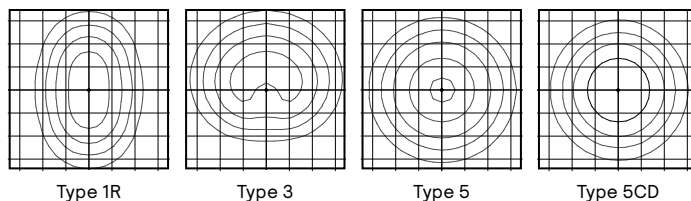

Finish

Each standard color luminaire receives a fade and abrasion resistant, electrostatically applied, thermally cured, triglycidic isocyanurate (**TGIC**) textured polyester powdercoat finish on lower housing.

Standard textured finishes include: **BZ** - Bronze Textured, **WH** - White Textured, **MG** - Medium Gray Textured. Consult factory for specs on optional (**OC**) or custom (**SC**) colors. The finish achieves a minimum scribe rating of 7 per ASTM D1654 after a minimum of 1500 hours salt spray in accordance with testing performed per ASTM B117 standard.

Hardware and Seals

All exposed screws shall be stainless steel and/or corrosion resistant and captive. All seals and sealing devices are made and/or lined with silicone and/or rubber.

LED Products Manufacturing Standard

The electronic components sensitive to electrostatic discharge (ESD) such as LEDs are assembled in compliance with EC61340-5-1 and ANSI/ESD S20.20 standards so as to eliminate ESD events that could decrease the useful life of the product.

LED Luminaire Useful Life

Refer to IES files for energy consumption and delivered lumens for each option. Based on ISTMT in situ thermal testing in accordance with UL1598 and UL8750, exclusive Signify System Reliability Tool, Advance driver data and LED manufacturer LM-80/TM-21 data, expected to reach 100,000+ hours with L70 lumen maintenance @ 25°C. Luminaire Useful Life accounts for LED lumen maintenance AND all of these additional factors including: LED color shift, LED life, driver life, PCB substrate, solder joints, on/off cycles, burning hours and corrosion.

Vibration resistance

Luminaire meets the ANSI C136.31-2018 specifications for Normal or Bridge / Overpass applications, as noted in Ordering guide on page 1 and in the Specifications text for each Mounting, tested by independent lab over 100,000 cycles in all three axes.

SVPG SoftView

Garage & canopy luminaire

Specifications

Certifications and Compliance

cULus Listed for Canada and U.S. to the UL 1598 and UL8750 standards, suitable for Wet Locations. Suitable for use in ambients from -40°C (-40°F) to +50°C (+122°F) up to A09, to +40°C (+104°F) for A10 and A11. The quality systems of the facility where manufactured have been registered by UL to the ISO 9001 series standards. Emergency Battery Backup options (**EM** and **EC**) are tested and listed emergency lighting devices per UL 924 and CSA 22.2 No. 141. SoftView configurations are DesignLights Consortium qualified, consult DLC QPL Qualified Products List for more details. Controls options enable compliance with Outdoor lighting energy codes including ASHRAE 90.1, California Title 24, and IECC.

Limited Warranty

5-year limited warranty.
See [signify.com/warranties](https://www.signify.com/warranties) for complete details and exclusions.

Buy American Act of 1933 (BAA)

Failure to properly select the "BAC" suffix could result in you receiving product that is not BAA compliant product with no recourse for an RMA or refund. This BAC designation hereunder does not address (i) the applicability of, or availability of a waiver under, the Trade Agreements Act, or (ii) the "Buy America" domestic content requirements imposed on states, localities, and other non-federal entities as a condition of receiving funds administered by the Department of Transportation or other federal agencies.

Predicted Lumen Depreciation Data

Predicted performance derived from LED manufacturer's data and engineering design estimates, based on IESNA LM-80 methodology. Actual experience may vary due to field application conditions. L70 is the predicted time when LED performance depreciates to 70% of initial lumen output. Calculated per IESNA TM21-11. Published L70 hours limited to 6 times actual LED test hours

Ambient Temperature °C	Drive current	Calculated L70 Hours	L70 per TM-21	Lumen Maintenance % at 60,000 hrs
25°C	up to 3400 mA (A11)	>100,000 hours	>72,000 hours	>90%