



Hadco TownView LED post top luminaires were designed to eliminate the compromises of performance, comfort, style options and value when choosing the right lighting solution for residential street and pedestrian area. The horizontal lens option reduces glare to enhance a sense of security with increased visual comfort. TownView offers design flexibility with a variety of style options, lumen packages, a range of control options and more at exceptional value.

Project: \_\_\_\_\_  
 Location: \_\_\_\_\_  
 Cat.No: \_\_\_\_\_  
 Type: \_\_\_\_\_  
 Lamps: \_\_\_\_\_ Qty: \_\_\_\_\_  
 Notes: \_\_\_\_\_

#### Ordering guide: Luminaire

Example: TVLN-S3-S-16-G1-5-2S-740-A-N-R7-N-SP1-T-N-B-BK

Series	Mounting	Roof option	LED module	Generation	Drive current	Distribution	Color temp.	Voltage	Driver Option <sup>3</sup>
<b>TVLN</b> TownView with no lens	<b>A<sup>1</sup></b> Arm Mt	<b>S</b> Square Roof	<b>16</b> 16 LEDs	<b>G1</b> Gen 1	<b>5</b> 530 mA <b>7</b> 700 mA <b>9</b> 900 mA <b>1</b> 1050 mA	<b>2SH</b> Type 2 Short House-side shield <b>2S</b> Type 2 Short <b>3S</b> Type 3 Short <b>3SH</b> Type 3 Short House-side shield <b>3W</b> Type 3 Wide <b>3WH</b> Type 3 Wide House-side shield <b>5</b> Type 5	<b>730<sup>12</sup></b> 3000K, 70 CRI <b>740</b> 4000K, 70 CRI <b>827<sup>2</sup></b> 2700K, 80 CRI	<b>A</b> 120-277V <b>J</b> 480V <b>K</b> 347V	<b>DA<sup>5</sup></b> 4 Hrs 25% Reduction <b>DB<sup>5</sup></b> 4 Hrs 50% Reduction <b>DC<sup>5</sup></b> 4 Hrs 75% Reduction <b>DD<sup>5</sup></b> 6 Hrs 25% Reduction <b>DE<sup>5</sup></b> 6 Hrs 50% Reduction <b>DF<sup>5</sup></b> 6 Hrs 75% Reduction <b>DG<sup>5</sup></b> 8 Hrs 25% Reduction <b>DH<sup>5</sup></b> 8 Hrs 50% Reduction <b>DJ<sup>5</sup></b> 8 Hrs 75% Reduction <b>DL<sup>4.5</sup></b> DALI (default: logarithmic) <b>CLO<sup>5</sup></b> Constant light output <b>AST<sup>5</sup></b> Adjustable startup time <b>OTL<sup>5</sup></b> Over the life (default: L70 hrs) <b>S<sup>10</sup></b> FAWS Field adjustable wattage selector <b>SRD<sup>4.5</sup></b> Sensor ready driver (standard configuration) <b>N</b> None
<b>TVLC</b> TownView with comfort lens	<b>L4</b> Large Post Top Fitter 4" (tool less entry) <b>L3</b> Large Post Top Fitter 3" (tool less entry) <b>S2</b> Small Post Fitter 2-3/8" <b>S3</b> Small Post Fitter 3" <b>S4</b> Small Post Fitter 4"	<b>C<sup>1</sup></b> Curved Roof	<b>32</b> 32 LEDs <b>48</b> 48 LEDs	<b>G1</b> Gen 1 <b>G1</b> Gen 1	<b>5</b> 530 mA <b>7</b> 700 mA <b>8</b> 800 mA <b>1</b> 1050 mA <b>5</b> 530 mA <b>7</b> 700 mA				

Photo Control Receptacle	Sensor Receptacle <sup>8</sup>	Surge Protection	Term Block	Decorative Option	Bird Guard	Finish <sup>9</sup>
<b>R7</b> 7 Pin toolless rotatable standard - no photocell <b>PH8<sup>7</sup></b> 7 Pin toolless rotatable standard - with photocell <b>PH9</b> 7 Pin toolless rotatable standard - with shorting cap <b>PHX<sup>5</sup></b> 7 Pin toolless rotatable standard - with long life photocell	<b>N</b> None <b>SR<sup>11</sup></b> SR Receptacle	<b>SP1</b> 10kV/10kA Surge Protector <b>SP2</b> 20kV/10kV Surge Protector	<b>T</b> Terminal Block <b>N</b> None	<b>L<sup>6</sup></b> Ladder Rest <b>N</b> None	<b>B</b> Bird guard <b>N</b> None	<b>BKS</b> Black Smooth <b>WHS</b> White Smooth <b>BZS</b> Bronze Smooth <b>GNS</b> Green Smooth <b>BK</b> Black Texture <b>WH</b> White Texture <b>BZ</b> Bronze Texture <b>GN</b> Green Texture

Footnotes see page 2.

# TVLC/TVLN TownView

## Post top and arm mount luminaire

### Ordering Guide: Arm mount

Must be ordered as a separate line item (if Arm Mount option is chosen for fixture).

Code	Mount	Width	Options	Finish
<b>TV</b>	<b>A</b>	<b>55</b>	<b>S</b>	
TV TownView	A Arm Mount	55 55.5" wide	S Decorative Scroll	<b>BKS</b> Black Smooth <b>WHS</b> White Smooth <b>BZS</b> Bronze Smooth <b>GNS</b> Green Smooth <b>BK</b> Black Texture <b>WH</b> White Texture <b>BZ</b> Bronze Texture <b>GN</b> Green Texture

Only available with Square roof

### Footnotes

- Only **S** Square roof available with **A** Arm Mount
- Consult factory for information and lead time
- Only pick one option from the Control list - for multiple control options consult the factory
- This option requires more information contact factory
- Only available with **120-277 V**
- Ladder rest option not available with Arm Mount
- Not available with **347V**
- Order a **TVLN** (no lens version if you want the SR Receptacle option) or consult factory to review sensor compatibility with panels.
- When any finish other than **BKS** or **BK** is selected cupola will be metal and painted to match finish. Cupola supplied with **BKS** or **BK** finish option may be used with Interact City Astro-Clock node. If using Interact City with other finishes, cupola must be removed and Astro-Clock node is not required. If using a taller node other than Interact City that requires a taller cupola, please contact factory.
- Position 10 is open for receptacle control, must use one or the other not BOTH.
- SR** Receptacle only available with 32 LED (receptacle is mounted in the middle of the boards) and **SRD** Driver is required if you choose this receptacle
- Only 3000K CCT and warmer/below **TVLN** (no lens version) are IDA International DarkSky Approved.

### Dimensions: Arm mount

#### TVPx-A-S

**Arm:** Made of aluminum tubing

**Decorative Element:** Bent aluminum decorative channel scroll mechanically assembled.

**Mounting Plate:** Made of aluminum, mechanically fastened to the pole.

#### EPA Values

	Weight	EPA
TVPx-A-S	14 lbs	1.98 ft <sup>2</sup> .

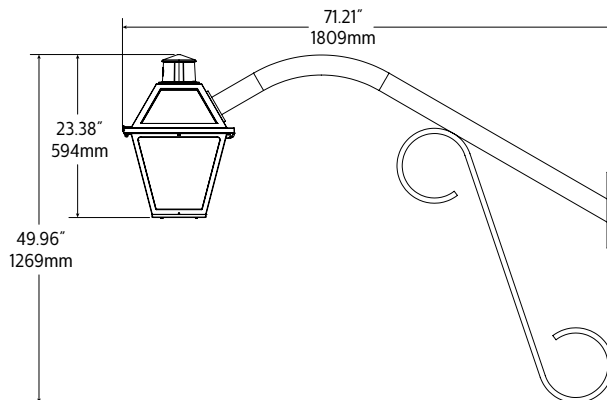

# TVLC/TVLN TownView

## Post top and arm mount luminaire

### Dimensions: Luminaire

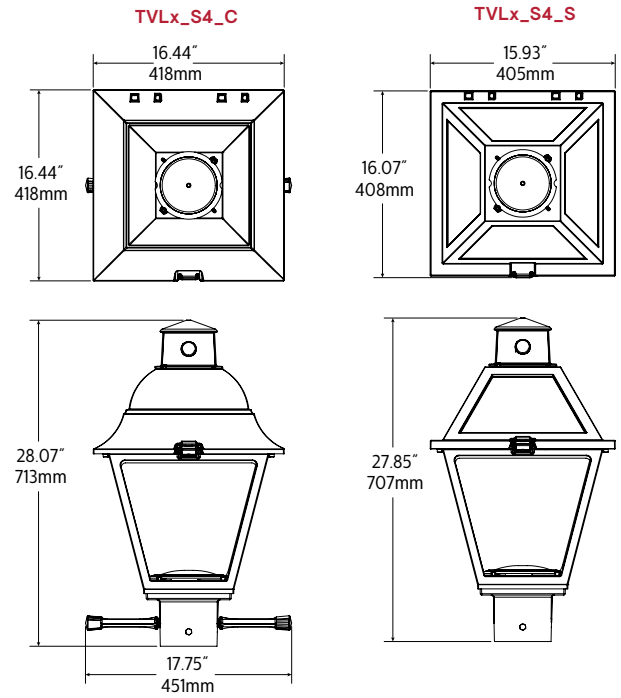
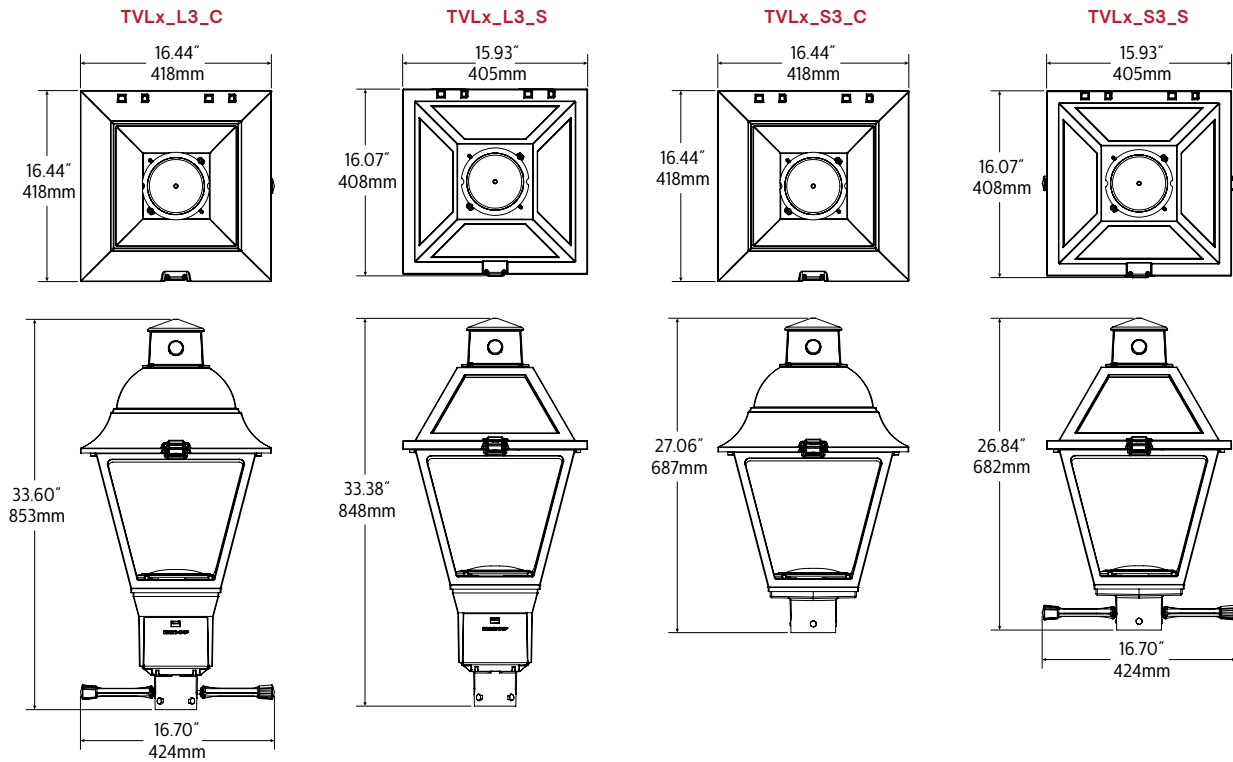

### EPA Values

	Weight	EPA
TVLx-L3-C	22.25 lbs	1.00 sq. ft.
TVLx-L3-S		
TVLx-S2/S3-C	21.00 lbs	0.76 sq. ft.
TVLx-S2/S3-S		
TVLx-S4-C	21.88 lbs	0.80 sq. ft.
TVLx-S4-S		
TVLx-A-S	19.63 lbs	0.69 sq. ft.

# TVLC/TVLN TownView

## Post top and arm mount luminaire

### Predicted Lumen Depreciation Data

Predicted performance derived from LED manufacturer's data and engineering design estimates, based on IESNA LM-80 methodology. Actual experience may vary due to field application conditions. L70 is the predicted time when LED performance depreciates to 70% of initial lumen output. Calculated per IESNA TM21-11. Published L70 hours limited to 6 times actual LED test hours.

Ambient Temperature °C	Driver mA	Calculated L70 Hours	L70 per TM-21	Lumen Maintenance % at 60,000 hrs
25°C	up to 1050 mA	>100,000 hours	>54,000 hours	>96%

### Field Adjustable Wattage (FAWS) Multiplier Chart

FAWS Position	Typical Delivered Lumens Multiplier	Typical System wattage
1	0.31	0.28
2	0.53	0.50
3	0.62	0.58
4	0.70	0.67
5	0.78	0.75
6	0.83	0.81
7	0.89	0.87
8	0.92	0.91
9	0.96	0.95
10	1.00	1.00

Note: Typical value accuracy +/- 5%

### LED Lumen values - TVLN (No lens)

Ordering Code	LED qty.	System Current (mA)	Color Temp.	Avg. System Wattage (W)	Type 2S			Type 3S			Type 3W			Type 5		
					Lumen Output	Efficacy (LPW)	BUG Rating	Lumen Output	Efficacy (LPW)	BUG Rating	Lumen Output	Efficacy (LPW)	BUG Rating	Lumen Output	Efficacy (LPW)	BUG Rating
TVLN-16-G1-5-x-730	16	530	3000	29	2,841	98	B1-U0-G1	3,009	104	B1-U0-G1	3,064	106	B1-U0-G1	3,189	110	B2-U0-G1
TVLN-16-G1-7-x-730	16	700	3000	38	3,594	94	B1-U0-G1	3,806	100	B1-U0-G1	3,876	102	B1-U0-G1	4,034	106	B3-U0-G1
TVLN-16-G1-9-x-730	16	900	3000	49	4,410	90	B1-U0-G1	4,671	96	B1-U0-G1	4,756	97	B1-U0-G2	4,950	101	B3-U0-G1
TVLN-16-G1-1-x-730	16	1050	3000	57	4,970	87	B1-U0-G1	5,264	93	B1-U0-G2	5,360	94	B1-U0-G2	5,579	98	B3-U0-G1
TVLN-32-G1-5-x-730	32	530	3000	53	5,645	106	B1-U0-G1	5,821	109	B1-U0-G2	5,878	110	B1-U0-G2	6,086	114	B3-U0-G1
TVLN-32-G1-7-x-730	32	700	3000	70	7,127	102	B1-U0-G1	7,350	105	B1-U0-G2	7,421	106	B2-U0-G2	7,684	109	B3-U0-G2
TVLN-32-G1-8-x-730	32	800	3000	80	7,933	99	B1-U0-G2	8,181	102	B1-U0-G2	8,261	103	B2-U0-G2	8,553	106	B3-U0-G2
TVLN-32-G1-1-x-730	32	1050	3000	108	9,963	92	B2-U0-G2	10,274	95	B2-U0-G2	10,374	96	B2-U0-G2	10,741	99	B4-U0-G2
TVLN-48-G1-5-x-730	48	530	3000	81	8,607	107	B2-U0-G2	8,876	110	B1-U0-G2	8,962	111	B2-U0-G2	9,279	115	B4-U0-G2
TVLN-48-G1-7-x-730	48	700	3000	105	10,805	103	B2-U0-G2	11,143	106	B2-U0-G2	11,251	105	B2-U0-G2	11,649	111	B4-U0-G2
TVLN-16-G1-5-x-740	16	530	4000	29	3,124	107	B1-U0-G1	3,308	113	B1-U0-G1	3,369	115	B1-U0-G1	3,506	120	B2-U0-G1
TVLN-16-G1-7-x-740	16	700	4000	39	3,951	103	B1-U0-G1	4,185	109	B1-U0-G1	4,261	111	B1-U0-G1	4,435	115	B3-U0-G1
TVLN-16-G1-9-x-740	16	900	4000	49	4,848	98	B1-U0-G1	5,135	104	B1-U0-G1	5,229	106	B1-U0-G2	5,442	110	B3-U0-G1
TVLN-16-G1-1-x-740	16	1050	4000	58	5,464	95	B1-U0-G1	5,788	101	B1-U0-G2	5,893	102	B1-U0-G2	6,134	107	B3-U0-G1
TVLN-32-G1-5-x-740	32	530	4000	54	6,207	115	B1-U0-G1	6,400	119	B1-U0-G2	6,463	120	B1-U0-G2	6,691	124	B3-U0-G1
TVLN-32-G1-7-x-740	32	700	4000	71	7,836	110	B1-U0-G1	8,081	114	B1-U0-G2	8,160	115	B2-U0-G2	8,448	119	B3-U0-G2
TVLN-32-G1-8-x-740	32	800	4000	81	8,722	107	B1-U0-G2	8,995	111	B1-U0-G2	9,082	112	B2-U0-G2	9,404	116	B3-U0-G2
TVLN-32-G1-1-x-740	32	1050	4000	110	10,954	100	B2-U0-G2	11,296	103	B2-U0-G2	11,406	104	B2-U0-G2	11,809	108	B4-U0-G2
TVLN-48-G1-5-x-740	48	530	4000	82	9,463	116	B2-U0-G2	9,758	119	B1-U0-G2	9,853	121	B2-U0-G2	10,202	125	B4-U0-G2
TVLN-48-G1-7-x-740	48	700	4000	106	11,880	112	B2-U0-G2	12,251	116	B2-U0-G2	12,370	117	B2-U0-G2	12,808	121	B4-U0-G2

Values from photometric tests performed in accordance with IESNA LM-79 and are representative of the configurations shown. Actual performance may vary due to installation and environmental variables, LED and driver tolerances, and field measurement considerations. It is highly recommended to confirm performance with a photometric layout.

Note: Some data may be scaled based on tests of similar (but not identical) luminaires. Contact factory for configurations not shown.

# TVLC/TVLN TownView

## Post top and arm mount luminaire

### LED Lumen values - TVLN (No lens and House-side shield)

Ordering Code	LED qty.	System Current (mA)	Color Temp.	Avg. System Wattage (W)	Type 2SH			Type 3SH			Type 3WSH		
					Lumen Output	Efficacy (LPW)	BUG Rating	Lumen Output	Efficacy (LPW)	BUG Rating	Lumen Output	Efficacy (LPW)	BUG Rating
TVLN-16-G1-5-x-730	16	530	3000	29	2,284	79	B0-U0-G0	2,495	86	B0-U0-G1	2,334	81	B0-U0-G1
TVLN-16-G1-7-x-730	16	700	3000	38	2,889	76	B0-U0-G1	3,156	83	B0-U0-G1	2,952	77	B0-U0-G1
TVLN-16-G1-9-x-730	16	900	3000	49	3,545	72	B0-U0-G1	3,873	79	B0-U0-G1	3,623	74	B0-U0-G1
TVLN-16-G1-1-x-730	16	1050	3000	57	3,996	70	B0-U0-G1	4,365	77	B0-U0-G1	4,083	72	B1-U0-G2
TVLN-32-G1-5-x-730	32	530	3000	53	4,462	84	B0-U0-G1	4,783	90	B1-U0-G2	4,693	88	B1-U0-G2
TVLN-32-G1-7-x-730	32	700	3000	70	5,634	80	B1-U0-G1	6,039	86	B1-U0-G2	5,926	84	B1-U0-G2
TVLN-32-G1-8-x-730	32	800	3000	80	6,271	78	B1-U0-G1	6,722	84	B1-U0-G2	6,596	82	B1-U0-G2
TVLN-32-G1-1-x-730	32	1050	3000	108	7,875	73	B1-U0-G2	8,442	78	B1-U0-G2	8,283	76	B1-U0-G2
TVLN-48-G1-5-x-730	48	530	3000	81	6,803	84	B1-U0-G1	7,293	90	B1-U0-G2	7,156	89	B1-U0-G2
TVLN-48-G1-7-x-730	48	700	3000	105	8,541	81	B1-U0-G2	9,156	87	B1-U0-G2	8,983	86	B1-U0-G2
TVLN-16-G1-5-x-740	16	530	4000	29	2,511	86	B0-U0-G0	2,743	94	B0-U0-G1	2,566	88	B0-U0-G1
TVLN-16-G1-7-x-740	16	700	4000	39	3,177	82	B0-U0-G1	3,470	90	B0-U0-G1	3,246	84	B0-U0-G1
TVLN-16-G1-9-x-740	16	900	4000	49	3,898	79	B0-U0-G1	4,258	86	B0-U0-G1	3,983	81	B0-U0-G1
TVLN-16-G1-1-x-740	16	1050	4000	58	4,393	76	B0-U0-G1	4,799	83	B0-U0-G1	4,489	78	B1-U0-G2
TVLN-32-G1-5-x-740	32	530	4000	54	4,906	91	B0-U0-G1	5,259	97	B1-U0-G2	5,160	96	B1-U0-G2
TVLN-32-G1-7-x-740	32	700	4000	71	6,194	87	B1-U0-G1	6,640	94	B1-U0-G2	6,515	92	B1-U0-G2
TVLN-32-G1-8-x-740	32	800	4000	81	6,894	85	B1-U0-G1	7,391	91	B1-U0-G2	7,252	89	B1-U0-G2
TVLN-32-G1-1-x-740	32	1050	4000	110	8,658	79	B1-U0-G2	9,282	85	B1-U0-G2	9,107	83	B1-U0-G2
TVLN-48-G1-5-x-740	48	530	4000	82	7,480	92	B1-U0-G1	8,018	98	B1-U0-G2	7,867	96	B1-U0-G2
TVLN-48-G1-7-x-740	48	700	4000	106	9,390	89	B1-U0-G2	10,066	95	B1-U0-G2	9,877	93	B1-U0-G2

### LED Lumen values - TVLC (Comfort lens)

Ordering Code	LED qty.	System Current (mA)	Color Temp.	Avg. System Wattage (W)	Type 2S			Type 3S			Type 3W			Type 5		
					Lumen Output	Efficacy (LPW)	BUG Rating	Lumen Output	Efficacy (LPW)	BUG Rating	Lumen Output	Efficacy (LPW)	BUG Rating	Lumen Output	Efficacy (LPW)	BUG Rating
TVLC-16-G1-5-x-730	16	530	3000	29	2,570	89	B1-U2-G1	2,598	90	B1-U2-G1	2,536	88	B1-U2-G1	2,654	92	B1-U2-G1
TVLC-16-G1-7-x-730	16	700	3000	38	3,251	85	B1-U2-G1	3,286	86	B1-U2-G1	3,208	84	B1-U2-G2	3,357	88	B2-U2-G1
TVLC-16-G1-9-x-730	16	900	3000	49	3,545	72	B1-U2-G1	4,033	82	B1-U2-G2	3,936	80	B1-U3-G2	4,120	84	B2-U2-G1
TVLC-16-G1-1-x-730	16	1050	3000	57	3,996	70	B1-U2-G1	4,545	80	B1-U2-G2	4,437	78	B1-U3-G2	4,643	82	B2-U3-G2
TVLC-32-G1-5-x-730	32	530	3000	53	5,190	97	B1-U3-G2	5,160	97	B1-U3-G2	5,010	94	B1-U3-G2	5,250	98	B2-U3-G2
TVLC-32-G1-7-x-730	32	700	3000	70	6,553	93	B2-U3-G2	6,515	93	B1-U3-G2	6,325	90	B1-U3-G3	6,628	94	B3-U3-G2
TVLC-32-G1-8-x-730	32	800	3000	80	7,294	91	B2-U3-G2	7,252	90	B2-U3-G2	7,041	88	B2-U3-G3	7,378	92	B3-U3-G2
TVLC-32-G1-1-x-730	32	1050	3000	108	9,160	85	B2-U3-G2	9,107	84	B2-U3-G3	8,842	82	B2-U3-G3	9,265	85	B3-U3-G3
TVLC-48-G1-5-x-730	48	530	3000	81	7,913	98	B2-U3-G2	7,867	97	B2-U3-G3	7,638	95	B2-U3-G3	8,004	99	B3-U3-G2
TVLC-48-G1-7-x-730	48	700	3000	105	9,934	95	B2-U3-G2	9,877	94	B2-U3-G3	9,589	91	B2-U3-G3	10,048	96	B3-U3-G3
TVLC-16-G1-5-x-740	16	530	4000	29	2,826	97	B1-U2-G1	2,856	98	B1-U2-G1	2,788	95	B1-U2-G1	2,918	100	B1-U2-G1
TVLC-16-G1-7-x-740	16	700	4000	39	3,574	93	B1-U2-G1	3,613	94	B1-U2-G1	3,527	92	B1-U3-G2	3,691	96	B2-U2-G1
TVLC-16-G1-9-x-740	16	900	4000	49	4,386	89	B1-U2-G1	4,434	90	B1-U2-G2	4,328	88	B1-U3-G2	4,529	92	B2-U3-G1
TVLC-16-G1-1-x-740	16	1050	4000	58	4,943	86	B1-U3-G1	4,997	87	B1-U3-G2	4,878	85	B1-U3-G2	5,105	89	B2-U3-G2
TVLC-32-G1-5-x-740	32	530	4000	54	5,706	106	B1-U3-G2	5,673	105	B1-U3-G2	5,508	102	B1-U3-G2	5,772	107	B3-U3-G2
TVLC-32-G1-7-x-740	32	700	4000	71	7,205	102	B2-U3-G2	7,163	101	B2-U3-G2	6,955	98	B2-U3-G3	7,287	103	B3-U3-G2
TVLC-32-G1-8-x-740	32	800	4000	81	8,019	99	B2-U3-G2	7,973	98	B2-U3-G3	7,741	95	B2-U3-G3	8,111	100	B3-U3-G2
TVLC-32-G1-1-x-740	32	1050	4000	110	10,071	92	B2-U3-G2	10,013	91	B2-U3-G3	9,721	89	B2-U3-G3	10,186	93	B3-U3-G3
TVLC-48-G1-5-x-740	48	530	4000	82	8,700	106	B2-U3-G2	8,650	106	B2-U3-G3	8,398	103	B2-U3-G3	8,800	108	B3-U3-G3
TVLC-48-G1-7-x-740	48	700	4000	106	10,922	103	B2-U3-G3	10,859	102	B2-U3-G3	10,543	99	B2-U3-G3	11,048	104	B3-U3-G3

Values from photometric tests performed in accordance with IESNA LM-79 and are representative of the configurations shown. Actual performance may vary due to installation and environmental variables, LED and driver tolerances, and field measurement considerations. It is highly recommended to confirm performance with a photometric layout.

**Note:** Some data may be scaled based on tests of similar (but not identical) luminaires. Contact factory for configurations not shown.

# TVLC/TVLN TownView

## Post top and arm mount luminaire

### Specifications

#### Housing

Roof and Cage: Two Style options  
**C:** Curved Roof and **S:** Square Roof. Tool-less latch made of stainless steel allows for quick access inside of the hinged roof to locate the driver, surge protector and optional FAWs (field adjustable wattage solution). Roof and Cage made of 360 die-cast aluminum alloy, low copper for high resistance to corrosion. Decorative Cupola on top of roof covers the 7 pin NEMA socket. Cupola rotatable 360 degrees, easily field removable by loosening two (2) hex head slotted screws that accept 1/4" flat blade screwdriver. If using a taller node other than Interact City that requires a taller cupola, please contact factory.

**Lens options:** **C:** Visual Comfort internal lens helps to eliminate glare and pixelization and gives a soft glow at night.

**N:** No internal flat lens for optimal performance

**Fitter:** Two fitter options. **L:** Large Utility Fitter with tool-less door to access the terminal block and wiring. Available in 3" or 4", both made of 360 die cast aluminum alloy, low copper for high resistance to corrosion. Large 4" fitter uses a secondary adapter to achieve 4" opening.

Or **S:** Small Fitter. Small fitter available in 2-3/8", 3" or 4". Small 2-3/8" and 3" both made of 360 die cast aluminum alloy, low copper for high resistance to corrosion. Small 4" made of 356 HM High-Strength cast aluminum, low copper for high resistance to corrosion. All hardware corrosion resistant stainless steel.

All fitter options use four (4) black cadmium corrosion resistant stainless steel hex head bolts at 90 degrees.

#### Light Engine

Composed of 4 main components: **LED Module / Optical System / Heat Sink / Driver.**

Electrical components are RoHS compliant, IP66 sealed light engine. LEDs tested by ISO 17025-2005 accredited lab in accordance with IESNA LM-80 guidelines, extrapolations in accordance with IESNA TM-21. Metal core board ensures greater heat transfer and longer lifespan.

#### LED Module

Composed of high-performance white LEDs. Color temperature as per ANSI/NEMA bin 2700 Kelvin nominal (2725 ±145K) CRI 80 min, 3000 Kelvin nominal (3045K +/- 175K) or 4000 Kelvin nominal (3985K +/- 275K), CRI 70 Min. 75 Typical. Other CCT/CRI also available, consult factory.

#### Heat Sink

Made of die cast aluminum optimizing the LEDs efficiency and life. Product does not use any cooling device with moving parts (only passive cooling device). Entire luminaire is rated for operation in ambient temperature of -40°C / -40°F up to +40°C / +104°F.

#### Optical System

Composed of high performance UV stabilized optical grade polymer refractor lenses to achieve desired distribution optimized to get maximum spacing, target lumens and a superior lighting uniformity. System is rated IP66. Performance shall be tested per LM-63, LM-79 and TM-15 (IESNA) certifying its photometric performance. Type **2S**, **3S**, **3W** and **Type 5** Street side indicated. House side shield optional (can be field installed) **2SH:** Type 2 with House Side Shield, **3SH:** Type 3 short with house side shield, **3WH:** Type 3 Wide with House side shield.

#### Driver

Driver comes standard with 0-10V dimming capability. High power factor of 95%. Electronic driver, operating range 50/60 Hz. Auto adjusting universal voltage input from 120 to 277, 347 and 480 VAC rated for both application line to line or line to neutral, Class I, THD of 20% max. Maximum ambient operating temperature from 40°F (4°C) to 130°F (55°C). Certified in compliance to UL1310 cULus requirement (dry and damp location). ] The current supplying the LEDs will be reduced by the driver if the driver experiences internal overheating as a protection to the LEDs and the electrical components. Output is protected from short circuits, voltage overload and current overload. Automatic recovery after correction. Standard built in driver surge protection of 2.5kV (min). Due to the inrush current that occurs with electronic drivers, recommend using a time-delay or slow blow fuse to avoid unwanted fuse blowing (false tripping) that can occur with normal or fast acting fuses.

#### Integrated Features

**R7\*:** Tool less rotatable receptacle with 7 pins enabling dimming and additional functionality (to be determined), can be used with a twist lock Interact City node or photoelectric cell or a shorting cap.

**SP1:** Surge protection device tested in accordance with ANSI/IEEE C62.45 per ANSI/IEEE C62.41.2 Scenario I Category C High Exposure 10kV/10kA waveforms for Line-Ground, Line-Neutral and Neutral-Ground, and in accordance with DOE MSSLC Model Specification for LED Roadway Luminaires Appendix D Electrical Immunity High test level 10kV/10kA.

**SP2:** Optional 20kV / 10kA surge protection device that provides extra protection beyond the SP1 10kV/10kA level.

**NEMA Labels:** Installed NEMA label, ANSI C136.15-2015 compliant. Consult factory for other labeling needs.

Please note that these integrated features always come with the luminaire.

\* Use of photoelectric cell or shorting cap is required to ensure proper illumination.

#### Driver and Luminaire Options

Dimming Options:

**DA:** 4 Hrs 25% reduction

**DB:** 4 Hrs 50% reduction

**DC:** 4 Hrs 75% reduction

**DD:** 6 Hrs 25% reduction

**DE:** 6 Hrs 50% reduction

**DF:** 6 Hrs 75% reduction

**DG:** 8 Hrs 25% reduction

**DH:** 8 Hrs 50% reduction

**DJ:** 8 Hrs 75% reduction

**DL:** Pre-set driver compatible with the DALI control system. Logarithmic standard

**AST:** Pre-set driver for progressive start-up of the LED module(s) to optimize energy management and enhance visual comfort at start-up.

**CLO:** Pre-set driver to manage the lumen depreciation by adjusting the power given to the LEDs offering the same lighting intensity during the entire lifespan of the LED module.

**OTL:** Pre-set driver to signal end of life of the LED module(s) for better fixture management.

**FAWS:** Field Adjustable Wattage Selector, pre-set to the highest position, can be easily switched in the field to the required position. This reduces total luminaire wattage consumption and reduces the light level - see the FAWS multiplier chart for more details.

Note: It is not recommended to use FAWS with other dimming or controls; if you do, set the switch to position 10 (maximum output) to enable the other dimming or controls. Switching FAWS to any position other than 10 will disable the other dimming or controls.

**DALI:** Pre-set driver compatible with DALI control system.

**SRD:** Sensor Ready Driver including SR communication (used for dimming and other functionalities), 24V auxiliary supply and a logical signal input (LSI) connected to the top NEMA twist lock receptacle.

**SRD1:** Sensor Ready Driver including SR communication (used for dimming and other functionalities) but with 24V auxiliary supply and a logical signal input (LSI) not connected to the top NEMA twist lock.

**PH8:** 7 Pin Toolless rotatable standard - with photocell. Photocell has dimensional limits: 3" dia x 2" tall (for non black finishes only)

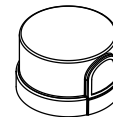

**PH9:** 7 Pin Toolless rotatable standard - with shorting cap

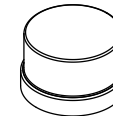

# TVLC/TVLN TownView

## Post top and arm mount luminaire

### Specifications (continued)

**PHX:** 7 Pin Tooless rotatable standard - with long life photocell. Photocell has dimensional limits: 3" dia x 2" tall (for non black finishes only)

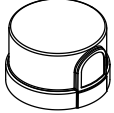

**SR:** Sensor ready receptacle located on the heat sink between two LED boards. Cannot be combined With 16 or 48 LED's or horizontal lens.

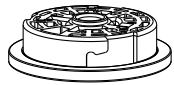

**L:** Decorative Ladder Rest. Ships in the box, install on site



**B:** Bird Guard optional. Attaches with two screws to the electrical cover. Can be ordered with the fixture or installed as a separate option later.



**2SH,  
3SH,  
3WH:** House side shield option

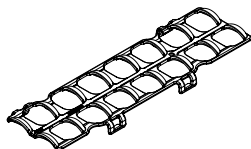

### Luminaire Useful Life

Refer to IES files for energy consumption and delivered lumens for each option. Based on ISTMT in situ thermal testing in accordance with UL1598 and UL8750, exclusive Signify System Reliability Tool, Advance driver data and LED manufacturer LM-80/TM-21 data, expected to reach 100,000 + hours (72W32LED and 108W48LED at 700mA) or 94,500 hours (108W32LED and 160W48LED at 1050mA) with >L70 lumen maintenance @ 25°C. Luminaire Useful Life accounts for LED lumen maintenance AND all of these additional factors including: LED color shift, LED life, driver life, PCB substrate, solder joints, on/off cycles, burning hours and corrosion. Lifetime statements do not include the use of controls, including networked controllers.

### Wiring

18AWG wire, 6" (15mm) minimum extending from luminaire.

### Optional Terminal block

Terminal block connector 600V, 85A for use with #14-2 AWG wires from the primary circuit, located inside the housing. Due to the inrush current that occurs with electronic drivers, recommend using a 10Amp time-delay fuse to avoid unwanted fuse blowing (false tripping) that can occur with normal or fast acting fuses. Fuses and holders by others or consult factory

### Hardware and Seals

All non-ferrous fasteners prevent corrosion and ensure longer life. All seals and sealing devices are made and/or lined with EPDM silicone rubber.

### Finish

Color in accordance with the AAMA 2603 standard. Application of polyester powder coat paint (4 mils/100 microns) with  $\pm 1$  mils / 24 microns of tolerance. The Thermosetting resins provides a discoloration resistant finish in accordance with the ASTM D2244 standard, as well as luster retention in keeping with the ASTM D523 standard and humidity proof in accordance with the ASTM D2247 standard. The standard finishes achieve a minimum scribe rating of 9 per ASTM D1654 after a minimum of 5000 hours salt spray in accordance with testing performed per ASTM B117 standard.

<b>BKS:</b>	Black Smooth
<b>WHS:</b>	White Smooth
<b>BZS:</b>	Bronze Smooth
<b>GNS:</b>	Green Smooth
<b>BK:</b>	Black Texture
<b>WH:</b>	White Texture
<b>BZ:</b>	Bronze Texture
<b>GN:</b>	Green Texture

### LED products manufacturing standard

The electronic components sensitive to electrostatic discharge (ESD) such as light emitting diodes (LEDs) are assembled in compliance with IEC61340-5-1 and ANSI/ESD S20.20 standards to eliminate ESD events that could decrease the useful life of the product.

### Vibration Resistance

S2, S3, S4 fitters and arm mount meets the ANSI C136.31, American National Standard for Roadway Luminaire Vibration specifications for Bridge/overpass applications (Tested for 3G over 100,000 cycles).

# TVLC/TVLN TownView

## Post top and arm mount luminaire

### Specifications (continued)

#### Certifications and Compliance

cETLus Listed for Canada and U.S. to the UL 1598 and UL8750 standards, suitable for Wet Locations. The quality systems of the facility where manufactured have been registered by UL to the ISO 9001 series standards. LM80 & LM79 tested. Configurations are DesignLights Consortium qualified, consult DLC QPL Qualified Products List for more details. Luminaire complies with or exceeds the following ANSI C136 standards: .2, .3, .10, .14, .15, .22, .25, .31, .37, .41. The TVLN with CCTs 3000K and warmer are Dark Sky Approved.

#### IP Ratings

IP66 rated LED light engine.

#### Service Tag

Each individual luminaire is uniquely identifiable, thanks to the Service tag application. With a simple scan of a QR code, placed on the inside of the mast door, you gain instant access to the luminaire configuration, making installation and maintenance operations faster and easier, no matter what stage of the luminaire's lifetime. Just download the APP and register your product right away.

For more details visit: [signify.com/global/service-tag](https://www.signify.com/global/service-tag)

#### Brackets and Poles

Visit the website for pole and post top bracket options

#### Warranty

5-year limited warranty. Options available for extended warranties – contact factory. See [signify.com/warranties](https://www.signify.com/warranties) for details and restrictions.

#### Buy American Act of 1933 (BAA)

This product is manufactured in one of our US factories and, as of the date of this document, this product was considered a commercially available off-the-shelf (COTS) item meeting the requirements of the BAA.

This BAA designation hereunder does not address (i) the applicability of, or availability of a waiver under, the Trade Agreements Act, or (ii) the "Buy America" domestic content requirements imposed on states, localities, and other non-federal entities as a condition of receiving funds administered by the Department of Transportation or other federal agencies. Prior to ordering, please visit [www.signify.com/baa](https://www.signify.com/baa) to view a current list of BAA-compliant products to confirm this product's current compliance.