



Lumec **Optima LED** post top and pendant luminaires are the perfect choice for urban projects such as streets, walkways and public spaces that compel that extra little bit of detail. This timeless luminaire is made from top-quality materials, is easy to maintain, and adds a distinctive decorative aspect to any contemporary environment. Paired with the latest LED technology, its IP66 rating, multiple lumen outputs, various luminaire style options and energy-saving control options are well suited to meet wide range of project requirements.

Project: _____
 Location: _____
 Cat.No: _____
 Type: _____
 Lamps: _____ Qty: _____
 Notes: _____

Ordering guide

example: XL10-72W32LED3K-G3-ACDR-LE3A-120-DMG-RC-GN8TX

Series	LED module	CCT	Gen. G3	Optical system	Voltage	Driver options	Options				Poles/ Brackets	Finish
							Receptacle	Control	Luminaire	Decorative		
XL10	35W32LED 55W32LED 72W32LED ⁷ 55W48LED 80W48LED	3K 3000K 4K 4000K	G3 Gen3	ACRD-LE2A Type II (ASYM) with acrylic globe ACRD-LE3A Type III (ASYM) with acrylic globe ACRD-LE4A Type IV (ASYM) with acrylic globe LE2F Type II (ASYM) w/flat glass lens LE2S Type II (ASYM) w/sag glass lens LE3F Type III (ASYM) w/flat glass lens LE3S Type III (ASYM) w/sag glass lens LE4F Type IV (ASYM) w/flat glass lens LE4S Type IV (ASYM) w/sag glass lens LE5F ³ Type V (SYMM) w/flat glass lens LE5S ³ Type V (SYMM) w/sag glass lens	UNV 120V-277V 347 480	DMG 0-10V SRD ¹ Sensor ready driver, standard configuration SRD1 ¹ Sensor ready driver, alternate configuration	RC ^{3,5} Receptacle for twist-lock photo cell or shorting cap, 3-pins	PH8 ⁶ Twist-lock Photoelectric Cell PH9 ⁶ Shorting cap PHXL ^{1,5} Twist-lock Photoelectric Cell extended life, UNV (120- 277VAC)	HS House Side Shield SP2 20kV / 10kA Surge protector TN2.875C Fitter to fit over a 2 7/8" (73 mm) O.D by 4" (102 mm) long tenon TN3 Fitter to fit over a 3" (76 mm) O.D by 4" (102 mm) long tenon TN3.5 Fitter to fit over a 3 1/2" (89 mm) O.D by 4" (102 mm) long tenon	CPT ⁵ Copper cupola CPTC ⁵ Varnished Copper cupola FN1 ⁵ Decorative finial FN2 ⁵ Decorative finial FN3 ⁵ Decorative finial FN4 ⁵ Decorative finial FN6 ⁵ Decorative finial FN8 ⁵ Decorative finial FN9 ⁵ Decorative finial FN10 ⁵ Decorative finial FNC ⁵ Decorative finial painted copper WC ⁴ Without cupola	Consult with Signify. com/ outdoor luminaires for details and the complete line of Signify poles and brackets.	Textured BE2TX Midnight Blue BE6TX Ocean Blue BE8TX Royal Blue BG2TX Sandstone BKTX Black BRTX Bronze GN4TX Blue Green GN6TX Forest Green GN8TX Dark Forest Green GNTX Green GY3TX Medium Grey RD2TX Burgundy RD4TX Scarlet WHTX White Other GR Gray Sandtex NP Natural Aluminum TG Hammerstone Gold

1. Not available 347-480 volt.
 2. Not available with HS option.
 3. Use of photoelectric cell or shorting cap (PH9) is required to ensure proper illumination.
 4. If RCD7 is required you need to select WC without cupola.
 The RCD7 is located on top of the roof in place of the cupola for use with a control node.
 5. Not available with WC option.
 Note: 5 or 7 pin receptacle is required contact factory
 6. RC or RCD7 must be selected for this option.
 7. Not available with SRD or SRD1.

XL10 Optima LED Post Top

Urban Luminaire

Dimensions

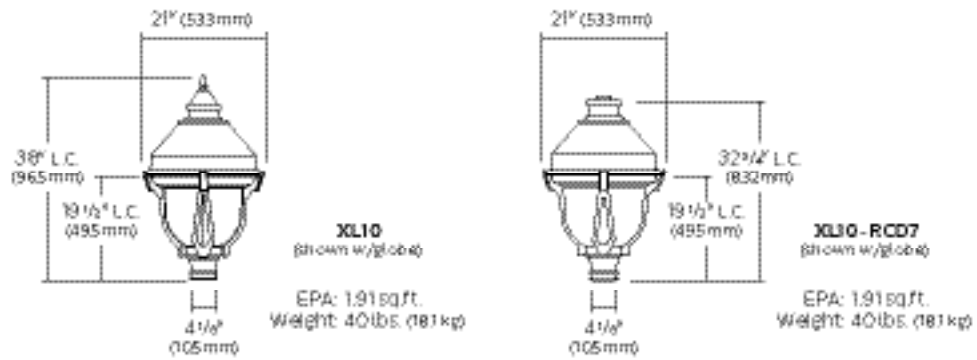

XL10 Optima LED Post Top

Urban Luminaire

LED Wattage and Lumen Values: for XL10

Ordering Code:	Total LEDs	LED current (mA)	Average System Wattage (W)	Lumen Output	BUG Rating	Efficacy (LPW)	Lumen Output	BUG Rating	Efficacy (LPW)	Lumen Output	BUG Rating	Efficacy (LPW)	Lumen Output	BUG Rating	Efficacy (LPW)
Flat Lens 3000K				LE2F			LE3F			LE4F			LE5F		
35W32LED3K-G3-x	32	350	37	4066	B1-U0-G1	110	4048	B1-U0-G1	109	4007	B1-U0-G1	108	3944	B3-U0-G1	107
55W32LED3K-G3-x	32	530	54	5833	B1-U0-G1	108	5807	B1-U0-G1	108	5747	B1-U0-G2	106	5657	B3-U0-G1	105
72W32LED3K-G3-x	32	700	73	7356	B2-U0-G1	101	7323	B1-U0-G2	100	7248	B1-U0-G2	99	7134	B3-U0-G2	98
55W48LED3K-G3-x	48	350	54	6100	B1-U0-G1	113	6072	B1-U0-G1	112	6010	B1-U0-G2	111	5916	B3-U0-G1	110
80W48LED3K-G3-x	48	530	80	8749	B2-U0-G1	109	8710	B2-U0-G2	109	8620	B2-U0-G2	108	8485	B3-U0-G2	106
Flat Lens 4000K				LE2F			LE3F			LE4F			LE5F		
35W32LED4K-G3-x	32	350	37	4269	B1-U0-G1	115	4250	B1-U0-G1	115	4207	B1-U0-G1	114	4141	B3-U0-G1	112
55W32LED4K-G3-x	32	530	54	6125	B1-U0-G1	113	6097	B1-U0-G1	113	6034	B1-U0-G2	112	5940	B3-U0-G1	110
72W32LED4K-G3-x	32	700	73	7724	B2-U0-G1	106	7689	B1-U0-G2	105	7610	B1-U0-G2	104	7491	B3-U0-G2	103
55W48LED4K-G3-x	48	350	54	6405	B1-U0-G1	119	6376	B1-U0-G1	118	6311	B1-U0-G2	117	6212	B3-U0-G1	115
80W48LED4K-G3-x	48	530	80	9186	B2-U0-G2	115	9146	B2-U0-G2	114	9051	B2-U0-G2	113	8909	B3-U0-G2	111
Sag Lens 3000K				LE2S			LE3S			LE4S			LE5S		
35W32LED3K-G3-x	32	350	37	4203	B1-U0-G1	114	4099	B1-U0-G1	111	4069	B1-U0-G1	110	3911	B3-U0-G1	106
55W32LED3K-G3-x	32	530	54	6029	B1-U0-G1	112	5879	B1-U0-G1	109	5836	B1-U0-G2	108	5610	B3-U0-G1	104
72W32LED3K-G3-x	32	700	73	7603	B2-U0-G1	104	7415	B1-U0-G2	102	7361	B1-U0-G2	101	7075	B3-U0-G2	97
55W48LED3K-G3-x	48	350	54	6304	B1-U0-G1	117	6148	B1-U0-G2	114	6104	B1-U0-G2	113	5866	B3-U0-G1	109
80W48LED3K-G3-x	48	530	80	9043	B2-U0-G2	113	8819	B1-U0-G2	110	8755	B1-U0-G2	109	8414	B3-U0-G2	105
Sag Lens 4000K				LE2S			LE3S			LE4S			LE5S		
35W32LED4K-G3-x	32	350	37	4413	B1-U0-G1	119	4304	B1-U0-G1	116	4272	B1-U0-G1	115	4107	B3-U0-G1	111
55W32LED4K-G3-x	32	530	54	6330	B1-U0-G1	117	6173	B1-U0-G1	114	6128	B1-U0-G2	113	5891	B3-U0-G1	109
72W32LED4K-G3-x	32	700	73	7983	B2-U0-G2	109	7786	B1-U0-G2	107	7729	B1-U0-G2	106	7429	B3-U0-G2	102
55W48LED4K-G3-x	48	350	54	6619	B1-U0-G1	123	6455	B1-U0-G2	120	6409	B1-U0-G2	119	6159	B3-U0-G1	114
80W48LED4K-G3-x	48	530	80	9495	B2-U0-G2	119	9260	B2-U0-G2	116	9193	B1-U0-G2	115	8835	B4-U0-G2	110
Prism Globe 3000K				LE2A			LE3A			LE4A					
35W32LED3K-G3-x	32	350	37	4131	B1-U3-G1	112	4014	B1-U3-G1	108	4166	B1-U3-G1	113	-	-	-
55W32LED3K-G3-x	32	530	54	5926	B1-U3-G1	110	5691	B1-U3-G1	105	5976	B1-U3-G2	111	-	-	-
72W32LED3K-G3-x	32	700	73	7473	B2-U3-G2	102	7210	B2-U3-G2	99	7537	B1-U3-G2	103	-	-	-
55W48LED3K-G3-x	48	350	54	6197	B1-U3-G1	115	6119	B1-U3-G2	113	6249	B1-U3-G2	116	-	-	-
80W48LED3K-G3-x	48	530	80	8888	B2-U3-G2	111	8542	B2-U3-G2	107	8964	B2-U3-G2	112	-	-	-
Prism Globe 4000K				LE2A			LE3A			LE4A					
35W32LED4K-G3-x	32	350	37	4338	B1-U3-G1	117	4215	B1-U3-G1	114	4374	B1-U3-G1	118	-	-	-
55W32LED4K-G3-x	32	530	54	6222	B1-U3-G1	115	5976	B1-U3-G2	111	6275	B1-U3-G2	116	-	-	-
72W32LED4K-G3-x	32	700	73	7847	B2-U3-G2	107	7571	B2-U3-G2	104	7914	B1-U3-G2	108	-	-	-
55W48LED4K-G3-x	48	350	54	6507	B1-U3-G1	121	6425	B1-U3-G2	119	6561	B1-U3-G2	122	-	-	-
80W48LED4K-G3-x	48	530	80	9332	B2-U3-G2	117	8969	B2-U3-G2	112	9412	B2-U3-G2	118	-	-	-

Actual performance may vary due to installation variables including optics, mounting/ceiling height, dirt depreciation, light loss factor, etc.; highly recommended to confirm performance with a layout - contact Applications at signify.com/outdoorluminaire.

Note: Some data may be scaled based on tests of similar. But not identical luminaires.

XL10 Optima LED Post Top

Urban Luminaire

LED Wattage and Lumen Values: for XL10 with Globe

Ordering Code: Sag lens (3000K)	Total LEDs	LED current (mA)	Average System Wattage ¹ (W)	LE2S			LE3S			LE4S			LE5S		
				Lumen Output ²	Efficacy (LPW)	BUG Rating	Lumen Output ²	Efficacy (LPW)	BUG Rating	Lumen Output ²	Efficacy (LPW)	BUG Rating	Lumen Output ²	Efficacy (LPW)	BUG Rating
XL10-35W32LED3K-G2	32	350	37	3233	87	B1-U0-G1	3153	85	B1-U0-G1	3130	85	B1-U0-G1	3259	88	B2-U0-G1
XL10-55W32LED3K-G2	32	530	54	4637	86	B1-U0-G1	4523	84	B1-U0-G1	4490	83	B1-U0-G1	4675	87	B3-U0-G1
XL10-72W32LED3K-G2	32	700	73	5849	80	B1-U0-G1	5704	78	B1-U0-G1	5662	78	B1-U0-G2	5896	81	B3-U0-G1
XL10-55W48LED3K-G2	48	350	54	4850	90	B1-U0-G1	4730	88	B1-U0-G1	4695	87	B1-U0-G1	4889	91	B3-U0-G1
XL10-80W48LED3K-G2	48	530	80	6956	87	B1-U0-G1	6784	85	B1-U0-G2	6734	84	B1-U0-G2	7012	88	B3-U0-G2

Ordering Code: Sag lens (4000K)	Total LEDs	LED current (mA)	Average System Wattage ¹ (W)	LE2S			LE3S			LE4S			LE5S		
				Lumen Output ²	Efficacy (LPW)	BUG Rating	Lumen Output ²	Efficacy (LPW)	BUG Rating	Lumen Output ²	Efficacy (LPW)	BUG Rating	Lumen Output ²	Efficacy (LPW)	BUG Rating
XL10-35W32LED4K-G2	32	350	37	3621	98	B1-U0-G1	3531	95	B1-U0-G1	3506	95	B1-U0-G1	3650	99	B3-U0-G1
XL10-55W32LED4K-G2	32	530	54	5194	96	B1-U0-G1	5065	94	B1-U0-G1	5028	93	B1-U0-G2	5236	97	B3-U0-G1
XL10-72W32LED4K-G2	32	700	73	6550	90	B1-U0-G1	6388	88	B1-U0-G2	6342	87	B1-U0-G2	6603	90	B3-U0-G2
XL10-55W48LED4K-G2	48	350	54	5431	101	B1-U0-G1	5297	98	B1-U0-G1	5258	97	B1-U0-G2	5475	101	B3-U0-G1
XL10-80W48LED4K-G2	48	530	80	7791	97	B2-U0-G2	7598	95	B1-U0-G2	7543	94	B1-U0-G2	7853	98	B3-U0-G2

Actual performance may vary due to installation variables including optics, mounting/ceiling height, dirt depreciation, light loss factor, etc.; highly recommended to confirm performance with a layout - contact Applications at signify.com/outdoorluminaires.

Note: Some data may be scaled based on tests of similar. But not identical luminaires.

XL10 Optima LED Post Top

Urban Luminaire

LED Wattage and Lumen Values: for XL10 with Globe

Ordering Code: Globe (3000K)	Total LEDs	LED current (mA)	Average System Wattage ¹ (W)	LE2A			LE3A			LE4A		
				Lumen Output ²	Efficacy (LPW)	BUG Rating	Lumen Output ²	Efficacy (LPW)	BUG Rating	Lumen Output ²	Efficacy (LPW)	BUG Rating
XL10-35W32LED3K-G2	32	350	37	2759	75	B1-U3-G1	2601	70	B1-U2-G1	2794	76	B1-U2-G1
XL10-55W32LED3K-G2	32	530	54	3958	73	B1-U3-G1	3730	69	B1-U3-G1	4008	74	B1-U3-G1
XL10-72W32LED3K-G2	32	700	73	4992	68	B1-U3-G1	4705	64	B1-U3-G1	5055	69	B1-U3-G2
XL10-55W48LED3K-G2	48	350	54	4139	77	B1-U3-G1	3901	72	B1-U3-G1	4192	78	B1-U3-G1
XL10-80W48LED3K-G2	48	530	80	5937	74	B1-U3-G1	5596	70	B1-U3-G1	6012	75	B1-U3-G2

Ordering Code: Globe (4000K)	Total LEDs	LED current (mA)	Average System Wattage ¹ (W)	LE2A			LE3A			LE4A		
				Lumen Output ²	Efficacy (LPW)	BUG Rating	Lumen Output ²	Efficacy (LPW)	BUG Rating	Lumen Output ²	Efficacy (LPW)	BUG Rating
XL10-35W32LED4K-G2	32	350	37	3559	96	B1-U3-G1	2913	79	B1-U2-G1	3130	85	B1-U2-G1
XL10-55W32LED4K-G2	32	530	54	5105	95	B1-U3-G1	4178	77	B1-U3-G1	4489	83	B1-U3-G2
XL10-72W32LED4K-G2	32	700	73	6439	88	B1-U3-G1	5269	72	B1-U3-G1	5662	78	B1-U3-G2
XL10-55W48LED4K-G2	48	350	54	5339	99	B1-U3-G1	4369	81	B1-U3-G1	4695	87	B1-U3-G2
XL10-80W48LED4K-G2	48	530	80	7658	96	B2-U3-G2	6267	78	B1-U3-G2	6734	84	B1-U3-G2

Actual performance may vary due to installation variables including optics, mounting/ceiling height, dirt depreciation, light loss factor, etc.; highly recommended to confirm performance with a layout - contact Applications at signify.com/outdoorluminaire.

Note: Some data may be scaled based on tests of similar. But not identical luminaires.

XL10 Optima LED Post Top

Urban Luminaire

Specifications

Housing

Finial: Decorative cast 356 aluminum, mechanically assembled.

Cupola: Decorative spun aluminum 1100-0, mechanically mounted on hood.

Hood: Spun aluminum 1100 0 dome, mechanically assembled on the luminaire.

Guard: In a round shape with 4 arms, this guard is a one piece cast aluminum 356 welded to the fitter

Access-mechanism

A die cast A360 aluminum technical ring with latch and hinge. The mechanism shall offer tool free access to the inside of the luminaire. An embedded memory retentive gasket shall ensure weatherproofing.

Light engine

LEDgine composed of 5 main components: Heat Sink / Lens / LED lamp / Driver / Optical System. Electrical components are RoHS compliant.

LED engine

Composed of high-performance white LEDs. Color temperature as per ANSI/NEMA bin Neutral White, 4000 Kelvin nominal (3985K +/-275K or 3710K to 4260K) or Warm white, 3000 Kelvin nominal (3045K +/- 175K or 2870K to 3220K), CRI 70 Min. 75 Typical.

Lens

LExF / LEEx: Made of soda lime tempered glass lens, mechanically assembled and sealed onto the lower part of the heat sink.

LExA (Globe): Made of one-piece seamless injection-molded impact-resistant (DR) acrylic having an inner prismatic surface. The globe is mechanically assembled and sealed onto the lower part of the heat sink.

Heat sink

Made of cast aluminum optimizing the LEDs efficiency and life. Product does not use any cooling device with moving parts (only passive cooling device).

Optical system

Composed of high performance optical grade PMMA acrylic refractor lenses to achieve desired distribution optimized to get maximum spacing, target lumens and a superior lighting uniformity. Optical system is rated IP66.

LED Performance

Predicted lumen depreciation data ¹				
Ambient Temperature (°C)	Driver mA	Calculated L ₇₀ hours ^{1,2}	L ₇₀ per TM-21 ^{2,3}	Lumen Maintenance % @ 60,000 hours
25°C	700 mA	>100,000	>60,000	85%

1. Predicted performance derived from LED manufacturer's data and engineering design estimates, based on IESNA LM-80 methodology. Actual experience may vary due to field application conditions.
2. L₇₀ is the predicted time when LED performance depreciates to 70% of initial lumen output.
3. Calculated per IESNA TM21-11. Published L₇₀ hours limited to 6 times actual LED test hours.

Performance shall be tested per LM 63, LM 79 and TM 15 (IESNA) certifying its photometric performance. Street side indicated.



Prismatic globe: IP66 rated optical system, composed of individual pre-oriented lens to achieve desired distribution, assembled with globe having an inner prismatic surface permanently sealed onto the lower part of the heat sink.

LE2A - Type II (ASYM) with globe (ACDR)

LE3A - Type III (ASYM) with globe (ACDR)

LE4A - Type IV (ASYM) with globe (ACDR)



Sag lens: IP66 rated optical system, composed of individual pre-oriented lens to achieve desired distribution, assembled with a tempered-glass sag lens permanently sealed onto the lower part of the heat sink.

LE2S - Type II (ASYM) with sag glass lens

LE3S - Type III (ASYM) with sag glass lens

LE4S - Type IV (ASYM) with sag glass lens

LE5S - Type V (SYMM) with sag glass lens



Flat lens: IP66 rated optical system, composed of individual preoriented lens to achieve desired distribution, assembled with a tempered-glass flat lens permanently sealed onto the lower part of the heat sink.

LE2F - Type II (ASYM) with flat glass lens

LE3F - Type III (ASYM) with flat glass lens

LE4F - Type IV (ASYM) with flat glass lens

LE5F - Type V (SYMM) with flat glass lens

Driver

Driver comes standard with dimming compatible 0-10V. High power factor of 90% minimum. Electronic driver, operating range 50/60 Hz. Auto adjusting universal voltage input from 120 to 277 or 347 to 480 VAC rated for both application line to line or line to neutral, Class I, THD of 20% max. Maximum ambient operating temperature from 40°F (40°C) to 130°F (55°C). Certified in compliance to UL1310 cULus requirement. Dry and damp location. Assembled on a unitized removable tray with Tyco quick disconnect plug resisting to 221°F (105°C). The current supplying the LEDs will be reduced by the driver if the driver experiences internal overheating as a protection to the LEDs and the electrical components. Output is protected from short circuits, voltage overload and current overload. Automatic recovery after correction. Standard built in driver surge protection of 2.5kV (min).

Surge protector

Surge protector tested in accordance with ANSI/IEEE C62.45 per ANSI/IEEE C62.41.2 Scenario I Category C High Exposure 10kV/10kA waveforms for Line Ground, Line Neutral and Neutral Ground, and in accordance with U.S. DOE (Department of Energy) MSSLC (Municipal Solid State Street Lighting Consortium) model specification for LED roadway luminaires electrical immunity requirements for High Test Level 10kV / 10kA. SP2 20kV/20kA optional.

Driver options

DMG: Dimmable driver 0-10V.

SRD: Sensor Ready Driver including SR communication (used for dimming and other functionalities), 24V auxiliary supply and a logical signal input (LSI) connected to the top NEMA twist lock receptacle.

SRD1: Sensor Ready Driver including SR communication (used for dimming and other functionalities) but with 24V auxiliary supply and a logical signal input (LSI) not connected to the top NEMA twist lock.

XL10 Optima LED Post Top

Urban Luminaire

Specifications (continued)

Luminaire options

CPT Copper cupola

CPTC Varnished copper cupola



FN2 Decorative finial



FN3 Decorative finial



FN4 Decorative finial



FN6 Decorative finial



FN8 Decorative finial



FN9 Decorative finial



FN10 Decorative finial

FNC Decorative finial painted copper



HS
House
side shield

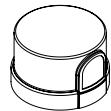

PH8
Photoelectric cell,
twist-lock type.
Allows 90° rotation



PH9
Shorting cap,
twist-lock type

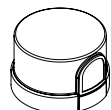

PHXL
Extended life Photoelectric
cell, twist-lock type
Allows 90° rotation



RC
Receptacle
3-pins



RCD7
Receptacle
7-pins

SP2 20kV/10kA integral
surge protector (optional)

WC Without Cupola

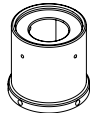

TN2.875C
2-7/8" dia.
tenon adaptor

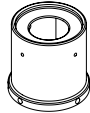

TN3
3" dia.
tenon adaptor

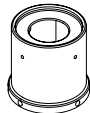

TN3.5
3-1/2" dia.
tenon adaptor

Fitter

Cast 356 aluminum c/w 4 set screws 3/8 16 UNC. This fitter holds 2 arms made of cast aluminum 356 mechanically assembled. Slip fits on a 4" (102mm) outside diameter X 4" (102mm) long tenon.

Finish

In accordance with the AAMA 2603 standard. Application of polyester powder coat paint (4 mils/100 microns) with +/- 1 mils/24 microns of tolerance. The Thermosetting resins provides a discoloration resistant finish in accordance with the ASTM D2244 standard, as well as luster retention in keeping with the ASTM D523 standard and humidity proof in accordance with the ASTM D2247 standard. The surface treatment achieves a minimum of 2000 hours for salt spray resistant finish in accordance with testing performed and per ASTM B117 standard.

Textured Finish Options:

BE2TX: Textured Midnight Blue
BE6TX: Textured Ocean Blue
BE8TX: Textured Royal Blue
BG2TX: Textured Sandstone
BKTX: Textured Black
BRTX: Textured Bronze
GN4TX: Textured Blue Green
GN6TX: Textured Forest Green
GN8TX: Textured Dark Forest Green
GNTX: Textured Green
GY3TX: Textured Medium Grey
RD2TX: Textured Burgundy
RD4TX: Textured Scarlet
WHTX: Textured White

Non-Textured Finish Options:

GR: Gray Sandtex
NP: Natural Aluminum
TG: Hammer-tone Gold

Luminaire useful life

Refer to IES files for energy consumption and delivered lumens for each option. Based on ISTMT in situ thermal testing in accordance with UL1598 and UL8750, using LM-80 data from LED manufacturers and engineering prediction methods, the luminaire useful life is expected to reach 100,000+ hours with >L70 lumen maintenance @ 25°C. Luminaire Useful Life accounts for LED lumen maintenance AND all of these additional factors including: LED life, driver life, PCB substrate, solder joints, on/off cycles, burning hours and corrosion. Entire luminaire is rated for operation in ambient temperature of -40°C / -40°F up to +35°C / +95°F.

Hardware

All exposed screws shall be complete with Ceramic primer-seal base coat to reduce seizing of the parts and offers a high resistance to corrosion. All seals and sealing devices are made and/or lined with EPDM and/or silicone and/or rubber.

Wiring

Gauge (#14) TEW/AWM 1015 or 1230 wires, 6" (152mm) minimum exceeding from luminaire.

Quality control

Manufactured to ISO 9001 2008 standards and ISO 14001-2004 International Quality Standards Certification.

LED products (manufacturing standard)

The electronic components sensitive to electrostatic discharge (ESD) such as light emitting diodes (LEDs) are assembled in compliance with IEC61340 5 1 and ANSI/ESD S20.20 standards so as to eliminate ESD events that could decrease the useful life of the product.

Quality control

Manufactured to ISO 9001 2015 standards and ISO 14001-2015 International Quality Standards Certification.

Certifications and Compliance

cULus Listed for Canada and USA.

Luminaires are DesignLights

Consortium qualified.

XL10 Optima LED Post Top

Urban Luminaire

Poles

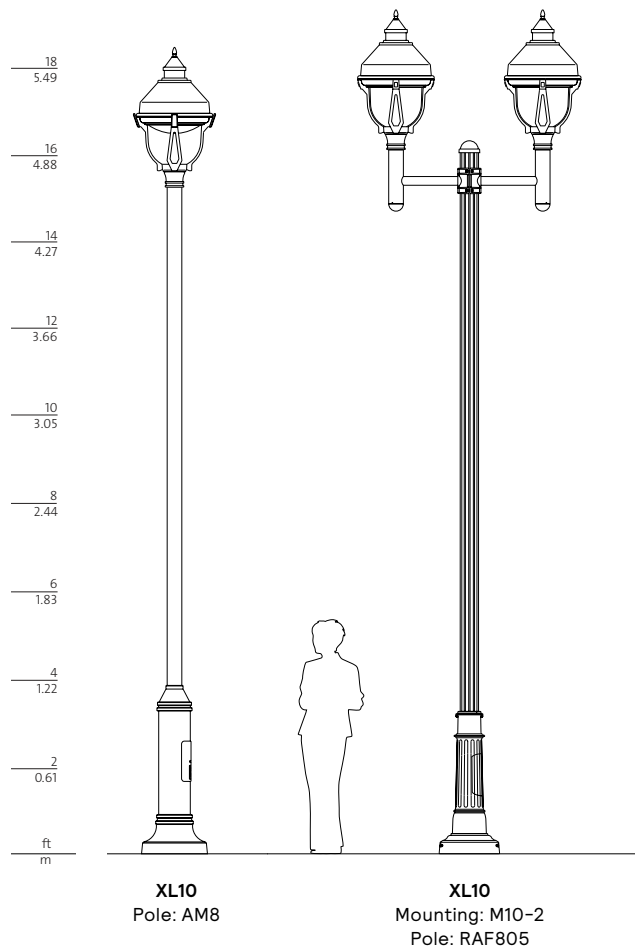

Consult Signify.com/outdoorluminaires for details and the complete line of Signify poles and brackets.



© 2023 Signify Holding. All rights reserved. The information provided herein is subject to change, without notice. Signify does not give any representation or warranty as to the accuracy or completeness of the information included herein and shall not be liable for any action in reliance thereon. The information presented in this document is not intended as any commercial offer and does not form part of any quotation or contract, unless otherwise agreed by Signify.

Signify North America Corporation
400 Crossing Blvd, Suite 600
Bridgewater, NJ 08807
Telephone: 800-555-0050

Signify Canada Ltd.
281 Hillmount Road,
Markham, ON, Canada L6C 2S3
Telephone: 800-668-9008

All trademarks are owned by Signify Holding or their respective owners.