

# Day-Brite

## CFI

by Signify

### Surface

#### Field Surface Frame

#### 4" Deep Field Surface Frame

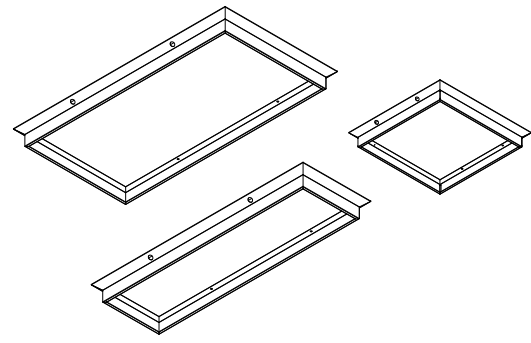

Philips Day-Brite / Philips CFI deep field surface frame is ideal for renovations and new construction opportunities where surface mounting is a necessity. The FSF allows for standard recessed luminaires to be adapted for surface installation. The FSF is a simple, time saving solution for surface mounting applications.

Project: \_\_\_\_\_  
Location: \_\_\_\_\_  
Cat.No: \_\_\_\_\_  
Type: \_\_\_\_\_  
Lamps: \_\_\_\_\_ Qty: \_\_\_\_\_  
Notes: \_\_\_\_\_

### Ordering guide

#### Catalog number

<b>FSF14</b>	1' x 4' field installed surface frame accessory.
<b>FSF22</b>	2' x 2' field installed surface frame accessory.
<b>FSF24</b>	2' x 4' field installed surface frame accessory.

### Product families compatible with the FSF

Family	Comment
<b>DualLED</b>	Not available for use with: emergency all sizes.
<b>EvoGrid</b>	Not available for use with: emergency for 1x4, SpaceWise (SWZG2). FSF must be removed for maintenance on emergency pack for 2x2 and 2x4 sizes.
<b>FluxGrid</b>	FSF must be removed for maintenance on emergency pack.
<b>FluxPanel</b>	FSF must be removed for maintenance on emergency pack.
<b>T-Grid</b>	Not available for use with: emergency all sizes.

### Application

- Designed for use with most configurations from DualLED, EvoGrid, FluxGrid, FluxPanel, and T-Grid product families
- 3-3/4" (95mm) overall depth with architectural profile

### Construction/Finish

- Field assembled frame (fasteners provided)
- Painted after fabrication white polyester powder coat
- Mounting holes provided in perimeter (4) allow for affixing to ceiling substrate from below

# FSF Field surface frame

## Accessory

### Dimensions

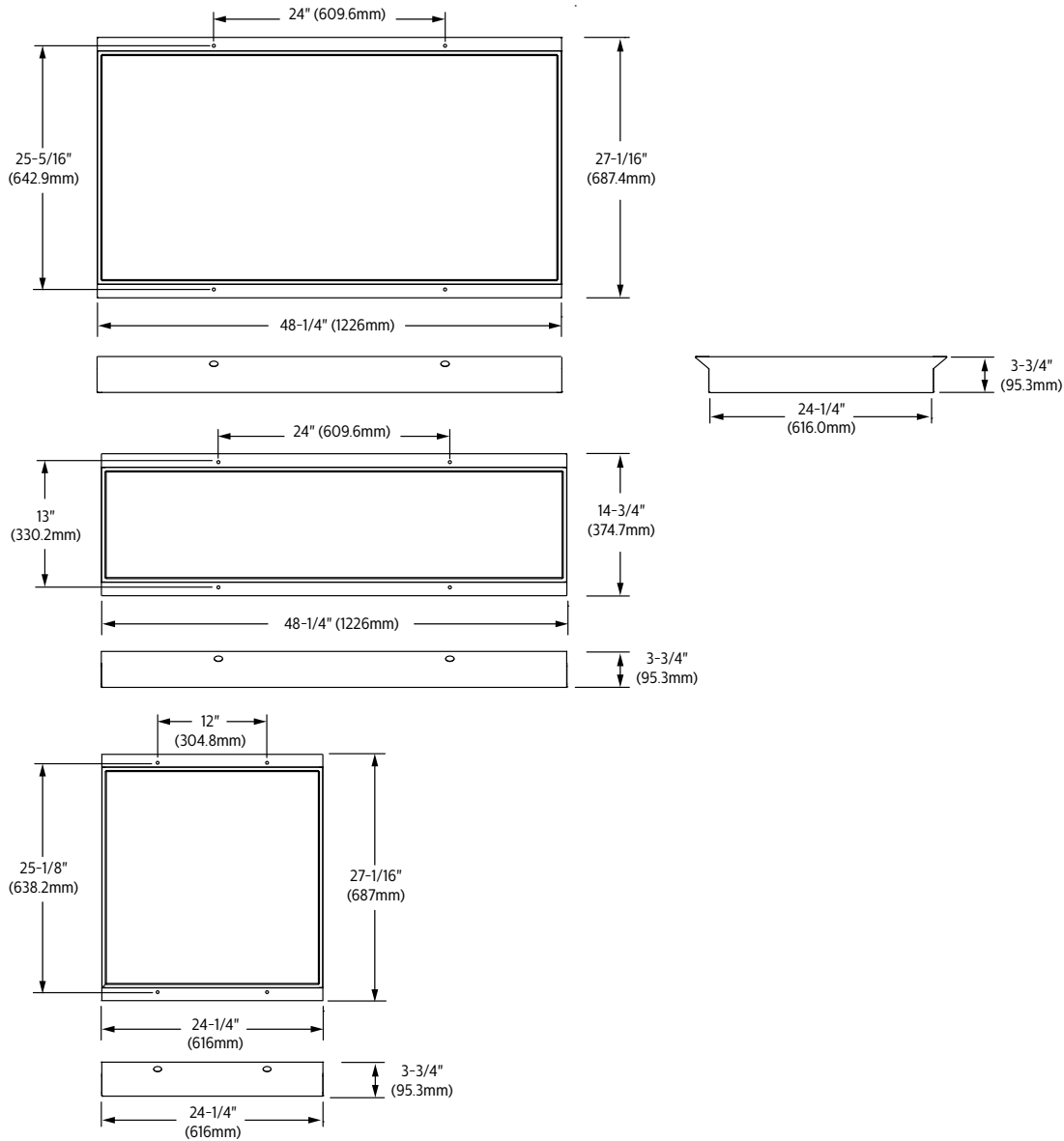

© 2019 Signify Holding. All rights reserved. This document contains information relating to the product portfolio of Signify which information may be subject to change. No representation or warranty as to the accuracy or completeness of the information included herein is given and any liability for any action in reliance thereon is disclaimed. All trademarks are owned by Signify Holding or their respective owners.

Signify North America Corporation  
200 Franklin Square Drive,  
Somerset, NJ 08873  
Telephone 855-486-2216

Signify Canada Ltd.  
281 Hillmount Road,  
Markham, ON, Canada L6C 2S3  
Telephone 800-668-9008