



Lumec TubeLine tunnel luminaire features a slim, low profile design that provides design flexibility for demanding tunnel applications. Product design consists of a luminaire and separate driver box, so please ensure to order both separately per the details below.

Project: _____
 Location: _____
 Cat.No: _____
 Type: _____
 Lumens: _____ Qty: _____
 Notes: _____

Ordering guide - Luminaire

example: TBL2-24L-740-G1-DTA-NB-Od1-W2S

Prefix	Module Length	LED Module Qty	CRI & CCT	Board Generation	Optical System	Mounting Bracket	Wire Entry
TBL	2			G1			
TBL TubeLine tunnel luminaire	2 2 meter Note: 1 meter version with 12 or 24 LEDs is available as special order. Please consult local representative.	24L 24 LEDs 48L 48 LEDs	730' 70CRI 3000K 740 70CRI 4000K	G1 Generation 1	Asymmetrical: DTA Standard Beam DTA-NB Narrow Beam DTA-WB Wide Beam Symmetrical: DTS Standard Beam DTS-NB Narrow Beam DTS-WB Wide Beam	Od1 Fix 0° version 1 Od2 Fix 0° version 2 SV Swivel	W1S Wired 1 side W2S Wired 2 sides

Ordering guide - Driver Box

example 1 driver: TBX-1D-D-UNV-DMG-GY3
 example 2 drivers: TBX-2D-F-F-UNV-DMG-GY3

Prefix	Driver Qty	Driver 1 Watt and Drive Current ²	Driver 2 Watt and Drive Current ^{2,3}	Ballast	Driver Options ⁵	Luminaire Options	Finish
TBX							GY3
TBX TubeLine tunnel/underpass driver box	1D 1 Driver 2D 2 Drivers	A ^{7,12} B ⁸ C D ^{7,12} E ⁸ F G ^{7,12} H ⁸ I J ^{7,12} K L ⁸	A ^{7,12} B ⁸ C D ^{7,12} E ⁸ F G ^{7,12} H ⁸ I J ^{7,12} K L ⁸	UNV 120-277VAC HVU 347-480VAC 120 ⁴ 120VAC 208 ⁴ 208VAC 240 ⁴ 240VAC 277 ⁴ 277VAC 347 ⁴ 347VAC 480 ⁴ 480VAC	DMG ⁶ 0-10V DALI ⁷ Digitally Addressable Lighting Interface SRD ⁷ Sensor Ready Driver standard configuration SRD1 ⁷ Sensor Ready Driver alternate configuration	API Factory Installed NEMA label, ANSI C136.15 compliant F1 ⁴ Single Fuse Holder F2 ^{4,13} Double Fuse Holder JB1 Junction Box, 1" NPT entries JB2 Junction Box, 3/4" NPT entries NER ¹⁰ Nyx Emera Ready SP2 20kV / 10kA Surge Protector (optional) TLL ⁹ Tool Less Entry Latches TLRSR ¹¹ SR receptacle VPA ⁹ Vandal Proof Access	GY3 Gray

- Extended lead-time may apply. Consult factory.
- See chart below for descriptions.
- Only available with 2D Driver Qty.
- Specific voltage (120, 208, 240, 277, 347 or 480) must be specified with fusing options (F1 or F2).
- Select either DALI or DMG or SRD or SRD1 mandatory option.
- Please note this integrated feature comes standard in this product.
- Not available with HVU, 347V and 480V.
- Only available with DMG Driver Options.
- TLL and VPA option cannot be selected together.
- Only available with 1D (1 Driver).
- Only available with SRD or SRD1 Driver Options.
- Not available with DMG Driver Option.
- Not available with JB1 or JB2 options

Driver Wattage and Current Selection Chart

Drive Current (mA)	Driver Wattage/Current selection (Min/Max refers to numbers of LEDs) ¹⁴					
	75W ¹⁵		100W ¹⁶		180W	
350	A	Min: 12	B	Min: 24	C	Min: 36
		Max: 24		Max: 48		Max: 96
530	D	Min: 12	E	Min: 24	F	Min: 36
		Max: 24		Max: 48		Max: 96
700	G	Min: 12	H	Min: 24	I	Min: 36
		Max: 24		Max: 48		Max: 84
1050	J	Min: 12	K	Min: 24	L	Min: 24
		Max: 24		Max: 24		Max: 60

Note: TBX system wattage is dictated by the sum of the luminaire wattages that are connected to it.
 14. Number of luminaires that can be driven by a driver is dependent on total number of LEDs of the luminaire daisy chain.
 15. Not available in HVU, 347, 480 or DMG Options.
 16. Available with DMG option only.

How to select driver box Watt and Drive current code:

- Select fixtures to be powered and drive current using Lumen chart
- Add the numbers of LEDs of the fixtures selected
- Select the code that match the total numbers of LEDs and Drive current selected
- If the total number of LEDs exceeds the Max of the chart, an additional daisy chain is required

Maximum number of fixtures in a daisy chain is driven by drive current and total number of LEDs
 TBX driver box can have one driver or 2 drivers. Each driver will drive one fixture daisy chain.

Note: Internal control options, like NER, cannot be used if 2 drivers are selected.

Example:

Qty 3 of TBL-2-24L-740-G1-DTS @350 mA fixtures must be powered:

Numbers of LEDs is 3x24 = 72 LEDs

Using chart, the maximum numbers of LEDs per driver @350 mA is 96 using code "C"

So ordering code info for this example would be:

Driver box: Qty 1 of TBX-1D-C-UNV-DMG-TLL-GY3

Fixtures: Qty 2 of TBL-2-24L-740-G1-DTS-0d1-W2S

Qty 1 of TBL-2-24L-740-G1-DTS-0d1-W1S



TBL TubeLine

Tunnel luminaire

Ordering example - Symmetrical Optics

TBX Driver Box - TBX-1D-C-UNV-DMG-TLL-GY3

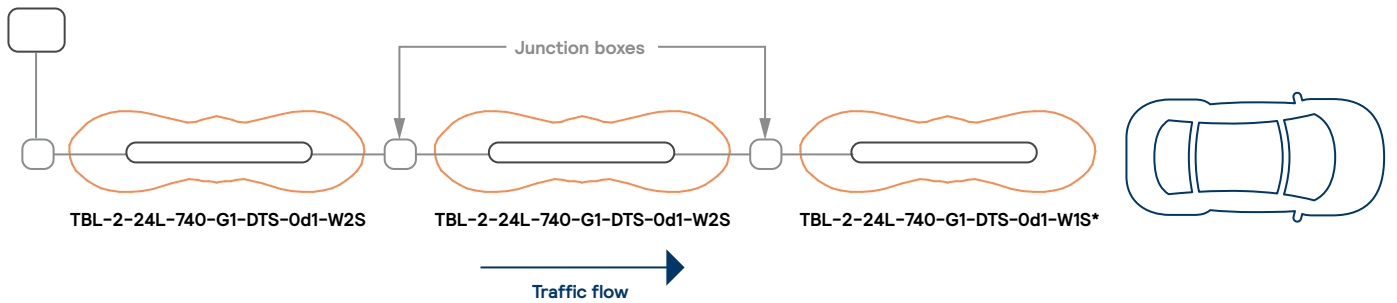

Ordering example - Asymmetrical Optics

TBX Driver Box - TBX-1D-C-UNV-DMG-TLL-GY3

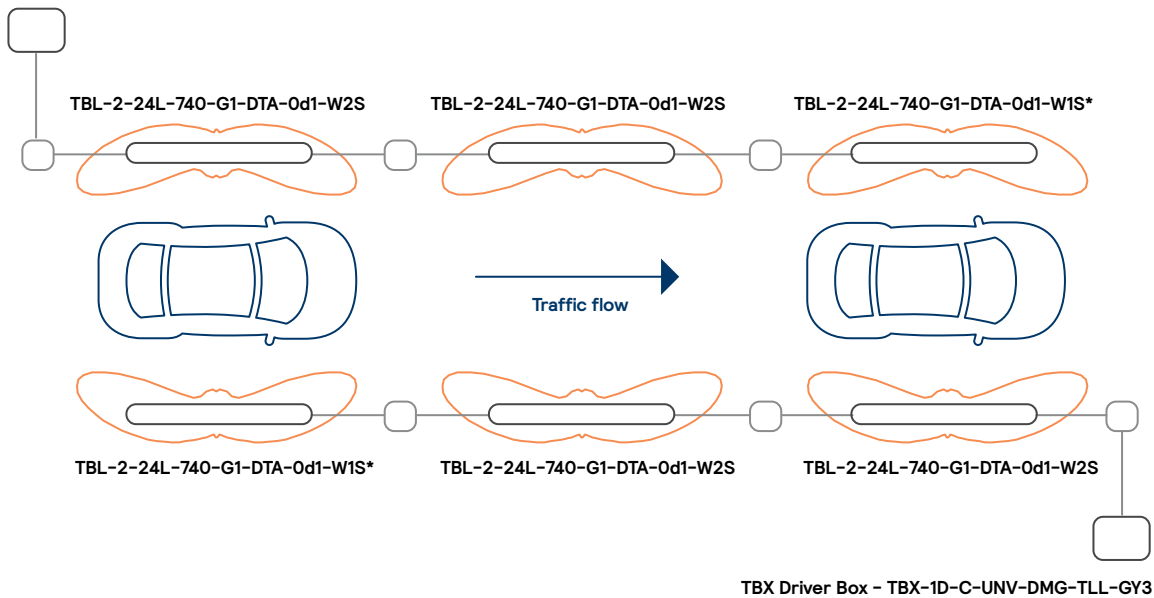

* Single fixture setup or last fixture in a daisy chained fixture series must be a type W1S

TBL TubeLine

Tunnel luminaire

Predicted Lumen Depreciation Data

Predicted performance derived from LED manufacturer's data and engineering design estimates, based on IESNA LM-80 methodology. Actual experience may vary due to field application conditions. L₇₀ is the predicted time when LED performance depreciates to 70% of initial lumen output. Calculated per IESNA TM21-11. Published L₇₀ hours limited to 6 times actual LED test hours

Ambient Temperature °C	Drive current	Calculated L70 Hours	L70 per TM-21	Lumen Maintenance % at 100,000 hrs
25°C	up to 1050 mA	>100,000 hours	>36,000 hours	>97%

LED Wattage Values

Ordering Code ¹	Total LEDs	System Current (mA)	Average System Watts ²
TBL2-24L-730-G1-x-350	24	350	31
TBL2-24L-730-G1-x-530	24	530	45
TBL2-24L-730-G1-x-700	24	700	58
TBL2-24L-730-G1-x-1050	24	1050	88
TBL2-48L-730-G1-x-350	48	350	57
TBL2-48L-730-G1-x-530	48	530	84
TBL2-48L-730-G1-x-700	48	700	110
TBL2-48L-730-G1-x-1050*	48	1050	167

LED Lumen Values – 3000K

Ordering Code	DTS-NB		DTS		DTS-WB		DTA-NB		DTA		DTA-WB	
	Lumen Output	Efficacy (LPW)	Lumen Output	Efficacy (LPW)	Lumen Output	Efficacy (LPW)	Lumen Output	Efficacy (LPW)	Lumen Output	Efficacy (LPW)	Lumen Output	Efficacy (LPW)
TBL2-24L-730-G1-x-350	3381	110	3326	109	3290	108	3181	104	3343	109	3220	105
TBL2-24L-730-G1-x-530	4894	110	4814	108	4762	107	4604	103	4839	108	4661	104
TBL2-24L-730-G1-x-700	6240	107	6139	105	6072	104	5871	101	6170	106	5943	102
TBL2-24L-730-G1-x-1050	8679	99	8539	97	8446	96	8166	93	8583	98	8266	94
TBL2-48L-730-G1-x-350	6657	117	6549	115	6478	114	6264	110	6583	116	6340	112
TBL2-48L-730-G1-x-530	9633	115	9477	113	9374	112	9064	108	9526	114	9174	110
TBL2-48L-730-G1-x-700	12229	111	12030	109	11900	108	11506	105	12093	110	11647	106
TBL2-48L-730-G1-x-1050*	16888	101	16614	100	16434	99	15890	95	16700	100	16084	96

LED Lumen Values – 4000K

Ordering Code	DTS-NB		DTS		DTS-WB		DTA-NB		DTA		DTA-WB	
	Lumen Output	Efficacy (LPW)	Lumen Output	Efficacy (LPW)	Lumen Output	Efficacy (LPW)	Lumen Output	Efficacy (LPW)	Lumen Output	Efficacy (LPW)	Lumen Output	Efficacy (LPW)
TBL2-24L-740-G1-x-350	3595	117	3600	118	3549	116	3542	116	3573	117	3457	113
TBL2-24L-740-G1-x-530	5203	117	5210	117	5136	115	5127	115	5172	116	5004	112
TBL2-24L-740-G1-x-700	6634	114	6643	114	6549	113	6537	112	6595	113	6381	110
TBL2-24L-740-G1-x-1050	9228	105	9241	105	9110	104	9093	104	9174	104	8876	101
TBL2-48L-740-G1-x-350	7078	125	7087	125	6987	123	6974	123	7036	124	6808	120
TBL2-48L-740-G1-x-530	10242	123	10256	123	10111	121	10092	121	10182	122	9851	118
TBL2-48L-740-G1-x-700	13002	118	13019	118	12836	117	12811	116	12925	118	12505	114
TBL2-48L-740-G1-x-1050*	17956	108	17980	108	17726	106	17692	106	17850	107	17270	104

Actual performance may vary due to installation variables including optics, mounting/ceiling height, dirt depreciation, light loss factor, etc.; highly recommended to confirm performance with a layout - contact Applications at outdoorlighting.applications@signify.com. Consult DLC QPL to confirm your specific fixture selection is DLC approved.

Note: Some data may be scaled based on tests of similar but not identical luminaires.

1. Drive current is dictated by the TBX driver box selection
2. Typical values for each fixture, rounded. System wattage of daisy chained fixtures are calculated by adding system wattage of each fixture in the daisy chain.

* Rated for operation in ambient temperature of -40°C / -40°F

Driver box dimensions

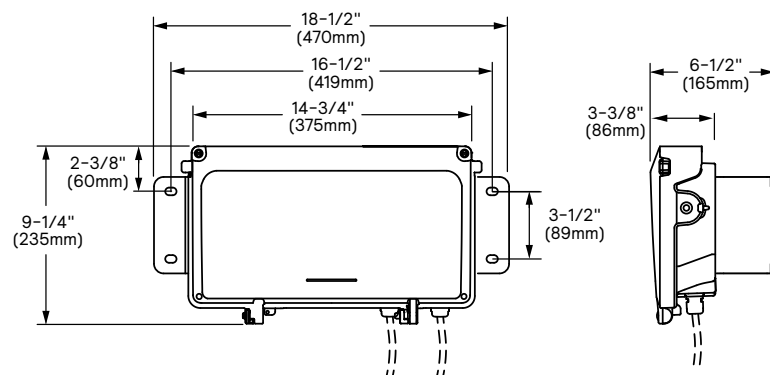

Weight: 9.9 lbs (13.4 lbs with JB1 or JB2 option)

JB1 /JB2 option

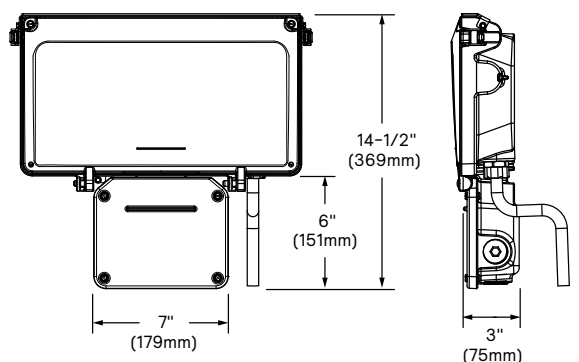

TBL TubeLine

Tunnel luminaire

Luminaire dimensions

Od1

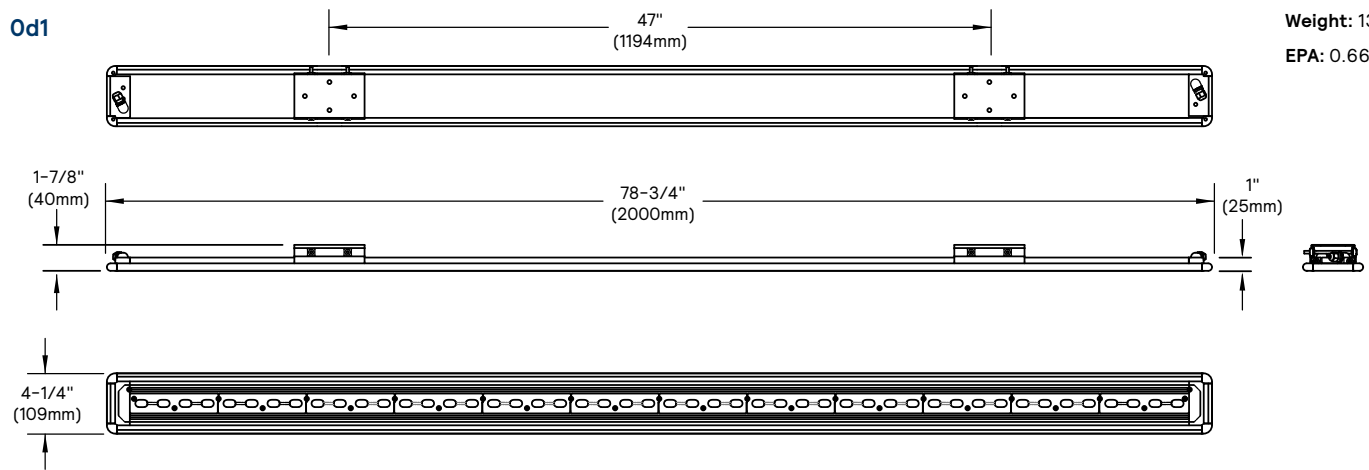

Weight: 13.3 lbs
EPA: 0.66 sq. feet

Od2



SV

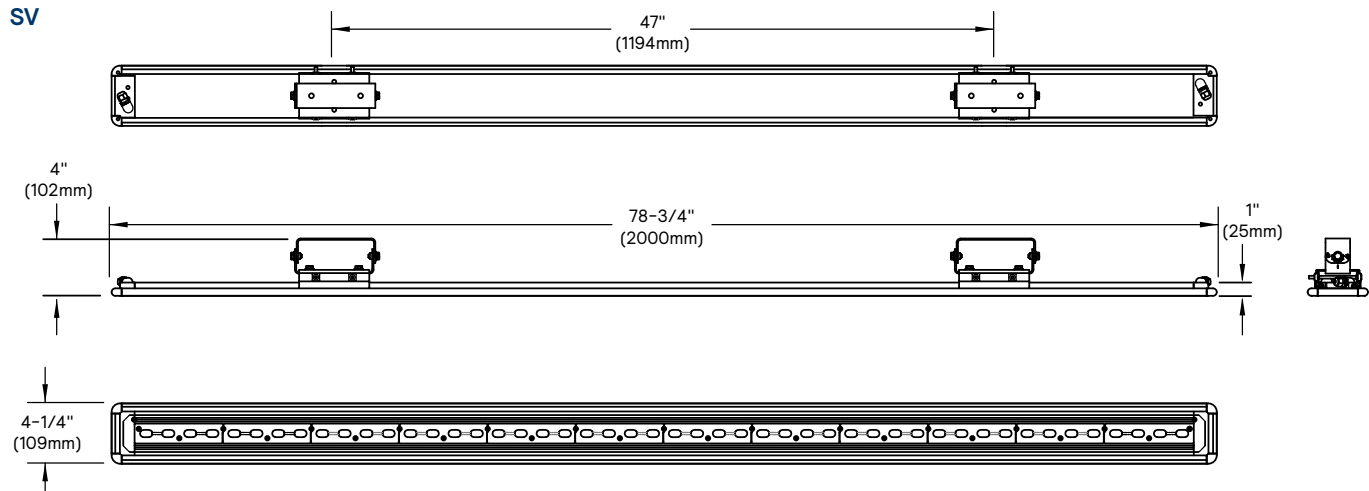

TBL TubeLine

Tunnel luminaire

Optical distributions

DTA
Distribution Asymmetrical Standard

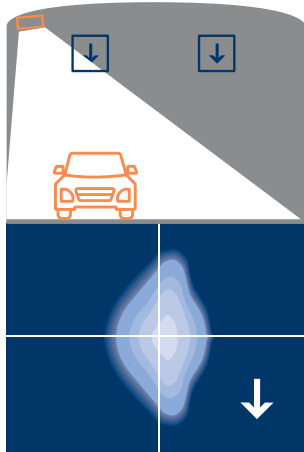

Arrows indicate traffic direction

DTA-WB
Distribution Asymmetrical Wide

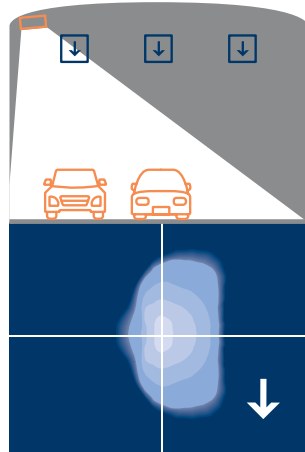

DTA-NB
Distribution Asymmetrical Narrow

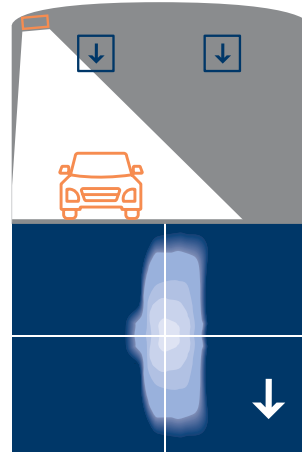

DTS
Distribution Symmetrical Standard

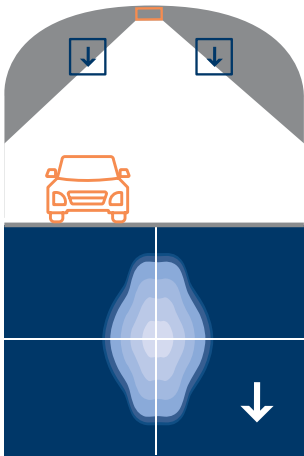

Arrows indicate traffic direction

DTS-WB
Distribution Symmetrical Wide

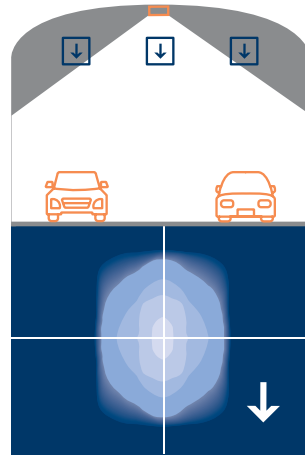

DTS-NB
Distribution Symmetrical Narrow

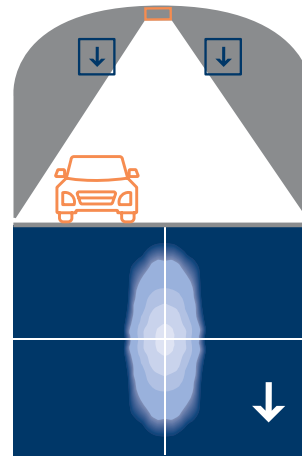

TBL TubeLine

Tunnel luminaire

Specifications

TBL Luminaire Housing

TBL luminaire is made of extruded anodized aluminum (6063) and a low copper die cast Aluminum alloy (LM6). Fixture is sealed and rated IP66 per ANSI C136.37.

TBX Driver Housing

TBX driver box is made of a low copper die cast Aluminum alloy (A360). Door is complete with hinges and is secured with flanged hex head screws with slotted drive providing access to electronic components and to a terminal block. Door is removable and is secured to prevent accidental dropping or disengagement. Compatible with 1/4" flat blade screwdriver. Complete with ANSI label as per C136.15-2015 to identify wattage and source (included in box). Label will show maximum wattage capacity of TBX, not actual wattage of fixture daisy chain. Housing (including electrical compartment) rated IP66 per ANSI C136.37.

TBL Light Engine

Composed of 5 main components: Heat Sink, Lens, LED Module, Optical System, Driver. Electrical components are RoHS compliant. LEDs tested by ISO 17025 2005 accredited lab in accordance with IESNA LM 80 guidelines in compliance with EPA ENERGY STAR, extrapolations in accordance with IESNA TM 21. Metal core board ensures greater heat transfer and longer lifespan.

Lens: Made of soda-lime clear tempered glass flat lens, mechanically assembled and sealed onto the lower part of the heat sink IK08.

LED Module: Composed of high performance white LEDs. Color temperature as per ANSI/NEMA bin 3000 Kelvin nominal (3045K +/-175K) or 4000 Kelvin nominal (3985K +/- 275K), CRI 70 Min. 75 Typical. Other CCT/CRI also available, consult factory.

Optical System: Composed of high performance UV stabilized optical grade polymer refractor lenses to achieve desired distribution optimized to get maximum spacing, target lumens and a superior lighting uniformity. System is rated IP66. Performance shall be tested per LM-63, LM-79 and TM-15 (IESNA) certifying its photometric performance.

Heat Sink: Built in the housing, designed to ensure high efficacy and superior cooling by natural convection air flow pattern always close to LEDs and driver optimizing their efficiency and life. Product does not use any cooling device with moving parts (only passive cooling). Entire luminaire is rated for operation in ambient temperature of -40°C / -40°F up to +50°C / +122°F unless otherwise specified, refer to LED Wattages Values Table.

TBX Driver Specifications

High power factor of 90% min. Electronic driver, operating range 50/60 Hz. Auto adjusting universal voltage input from 120 to 277 or 347 to 480 VAC rated for both application line to line or line to neutral, Class I, THD of 20% max. The current supplying the LEDs will be reduced by the driver if the driver experiences internal overheating as a protection to the LEDs and the electrical components. Output is protected from short circuits, voltage overload and current overload. Automatic recovery after correction. Standard built in driver surge protection of 2.5kV (min).

Controls: Driver is compatible with most controls system and can integrate proprietary and third parties control modules directly within the electrical compartment.

TBX Driver Integrated Features

DMG: Dimmable driver 0-10V.

SP1: Surge protection device tested in accordance with ANSI/IEEE C62.45 per ANSI/IEEE C62.41.2 Scenario I Category C High Exposure 10kV/10kA waveforms for Line-Ground, Line-Neutral and Neutral-Ground, and in accordance with DOE MSSLC Model Specification for LED Roadway Luminaires Appendix D Electrical Immunity High test level 10kV/10kA.

Please note that these integrated features always come with the TBX driver box.

TBX Driver Options

DALI: Pre-set driver compatible with the DALI control system.

SRD: Sensor Ready Driver including SR communication (used for dimming and other functionalities), 24V auxiliary supply and a logical signal input (LSI) connected to the NEMA twist lock receptacle and bottom TLRSR receptacle, if these options included/chosen. This configuration is compatible with Interact City controllers.

SRD1: Sensor Ready Driver including SR communication (used for dimming and other functionalities) but with 24V auxiliary supply and a logical signal input (LSI) not connected to the NEMA twist lock if this option included/chosen. If TLRSR receptacle option included, standard SR communication, 24V auxiliary supply and LSI are connected to the TLRSR receptacle.

SP2: 20kV/10kA surge protection device that provides extra protection beyond the SP1 10kV/10kA level.

TLRSR: SR Sensor connector, installed in fixture door. Shipped with protective cover.

API: Factory Installed NEMA label, ANSI C136.15-2015 compliant. Consult factory for other labeling needs.

F1: Fusing, single (120, 277 or 347VAC) installed in electrical compartment

F2: Fusing, double (208, 240 or 480VAC) installed in electrical compartment

JB1: Junction Box option, with 3 conduct entries, 1" NPT, suitable for through wire and continuous row mounting, complete with 2 aluminum hole plugs

JB2: Junction Box option, with 3 conduct entries, 3/4" NPT, suitable for through wire and continuous row mounting, complete with 2 aluminum hole plugs

NER: Fixture is set-up in factory to receive Nyx Hemera TLAC modules. (Modules can be factory installed as well. Consult factory for details)

TLL: Tool Free access 316 stainless steel latches.

VPA: Vandal Proof hardware to prevent access to internal components, 316 stainless steel, complete with Ceramic primer seal to reduce seizing of the parts, also offers a high resistance to corrosion.

** Use of photoelectric cell or shorting cap is required to ensure proper illumination.*

Luminaire Useful Life

Refer to IES files for energy consumption and delivered lumens for each option. Based on ISTMT in situ thermal testing in accordance with UL1598 and UL8750, Signify System Reliability Tool, Advance by Signify data and LED manufacturer LM-80/TM-21 data, expected to reach 100,000 + hours with L70 lumen maintenance @ 25°C.

Luminaire Useful Life accounts for LED lumen maintenance AND all of these additional factors including: LED life, driver life, PCB substrate, solder joints, on/off cycles, burning hours and corrosion.

TBL Luminaire Wiring

18AWG SEOWW cable 6 feet long through 1/2" NPT liquid tight cable gland is provided for connection. Connection can also be made using rigid or semi-rigid liquid tight conducts and IP66 rated 1/2" NPT fittings (not included). Multiple fixtures can be daisy chained when using the proper ordering code and driver box configuration. All connections means must be water tight and rated IP66. Liquid infiltration through customer supplied connections are not covered by warranty.

TBX Driver Box Wiring

The connection of the driver box is done using a terminal block connector 600V, 85A for use with #2-14 AWG. wires from the primary circuit, located inside the housing electrical compartment. Due to the inrush current that occurs with electronic drivers, recommend using a 10Amp time delay fuse to avoid unwanted fuse blowing (false tripping) that can occur with normal or fast acting fuses. Housing is completed with a 7/8" (22mm) diameter unthreaded mounting hole to accept a 1/2 NPT liquid tight cord grips connector IP66 rated minimum. Wiring, connector, sealing washer and locknut supplied by others.

TBL Mounting Options

Extruded clamp-on brackets are Anodized Aluminum. Fixed and Swivel bracket extensions are 316 Stainless Steel

TBX Driver Mounting Options

Mounting brackets are 316 Stainless Steel.

TBX Driver Hardware

All exposed screws shall be 316 stainless steel, complete with Ceramic primer seal to reduce seizing of the parts, also offers a high resistance to corrosion. All seals and sealing devices are made and/or lined with EPDM and/or silicone and/or rubber.

TBL TubeLine

Tunnel luminaire

TBX Driver Box Finish

Color in accordance with the AAMA 2603 standard. Application of polyester powder coat paint (4 mils/100 microns) with ± 1 mils/24 microns of tolerance. The Thermosetting resins provides a discoloration resistant finish in accordance with the ASTM D2244 standard, as well as luster retention in keeping with the ASTM D523 standard and humidity proof in accordance with the ASTM D2247 standard. The surface treatment achieves a minimum of 3000 hours for salt spray resistant finish in accordance with testing performed and per ASTM B117 standard.

LED products manufacturing standard

The electronic components sensitive to electrostatic discharge (ESD) such as light emitting diodes (LEDs) are assembled in compliance with IEC61340-5-1 and ANSI/ESD S20.20 standards so as to eliminate ESD events that could decrease the useful life of the product.

TBL Luminaire Vibration Resistance

The TBL luminaires meets the ANSI C136.31-2010 American National Standard for Roadway Luminaire Vibration specifications for Bridge/Overpass applications.

TBX Driver Box Vibration Resistance

The TBX driver box meets the ANSI C136.31-2018 American National Standard for Roadway Luminaire Vibration specifications for Bridge/Overpass applications.

Certifications and Compliance

cULus Listed for Canada and USA. Luminaire meets DOE and MSSLC Model Specification for LED Roadway Luminaires. Most versions are DesignLights Consortium® qualified, consult DLC QPL to confirm your specific fixture selection is approved. Luminaire complies with or exceeds the following ANSI C136 standards: .2, .3, .10, .14, .15, .22, .25, .31, .37, .41.

Service Tag

Each individual driver box is uniquely identifiable, thanks to the Signify Service tag application. With a simple scan of a QR code, placed on the inside of the mast door, you gain instant access to the luminaire configuration, making installation and maintenance operations faster and easier, no matter what stage of the luminaire's lifetime. Just download the APP and register your product right away. For more details visit: philips.com/servicetag

Limited Warranty

10-year limited warranty.

See signify.com/warranties for details and restrictions.

