

LUMEC

by  Signify

Redefining confidence

Roadway

RoadFocus





**"Why
should I
change?"**



Enhance your roadways

Chances are, you've considered LED roadway lighting, but when weighing the familiar performance and appearance of traditional roadway lighting against newer technologies, you may wonder how LED lives up to your stringent standards.

With new Lumec RoadFocus LED cobra head luminaires, you can now reliably upgrade to LED roadway lighting; saving energy, maintenance and operating costs, and contributing to environmental stewardship. At the same time, you'll benefit from performance surpassing that of high intensity discharge (HID) luminaires while retaining the familiar cobra head design.

RoadFocus LED luminaires offer more than an energy-efficient upgrade from traditional roadway lighting – they provide confident solutions to help enhance liveability in your city or town.



**"Will people
notice a change?"**

Surrounded by familiarity



RoadFocus LED luminaires have the same cobra head shape that people are used to seeing on roadways, so they effortlessly complement new areas and seamlessly retrofit into existing areas.

With three sizes, a sleek, low-profile design, and many options, RoadFocus extends the same uniform aesthetic throughout all of your roadway applications.

- Familiar cobra head aesthetics by day
- Powerful 70-400W HID replacement illumination at night
- Seamless installation in new and existing areas across all roadway applications including off road applications
- Optional stand-alone and connected outdoor LED lighting solutions further customize energy use and maximize the benefits of LED lighting



**"Is it
expensive?"**

Value: now and down the road

In addition to enhanced light output with excellent uniformity, RoadFocus LED luminaires can help to drive cost and work-flow efficiencies. Our luminaires are favorably priced, and also easily retrofit into existing infrastructures so you only purchase what you need, when you need it. Customized financing plans are also available to comfortably suit your budgetary requirements.

- LED technology and advanced connected lighting solutions reduce energy costs
- Long luminaire useful life up to 100,000 hours (L70), enhanced ROI
- Customized financing plans
- Fast payback

Safeguarding your investment

State-of-the-art LED technology found in RoadFocus LED luminaires contributes even more efficiency by lowering energy costs without sacrificing performance, while long luminaire lifetimes reduce maintenance and operating costs.

Returns on investment are further enhanced by incorporating our stand-alone and connected outdoor LED lighting solutions. From dimming that saves energy, to real-time alerts that enable quicker and more effective maintenance response, RoadFocus LED Luminaires with connected lighting solutions provide even greater savings.



"Where does it work?"

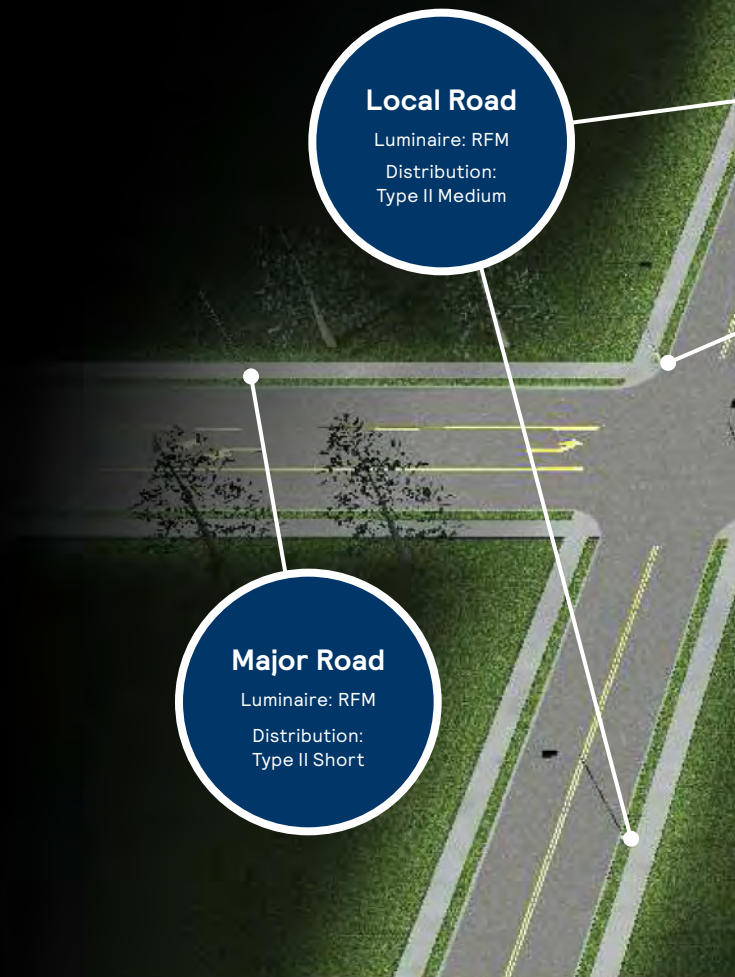

Local Road

Luminaire: RFM
Distribution:
Type II Medium

Major Road

Luminaire: RFM
Distribution:
Type II Short

Blankets of light

RoadFocus LED Luminaires are the only roadway lighting solution you will need. They provide reliable and uniform LED illumination ranging from 70 to 400W HID replacement, while exceeding the performance of traditional lighting technologies. Now, your city or town can enjoy well-lit roadways and an increased sense of security that extends from small alleys to multi-lane expressways.

- Superior uniformity enhances visibility
- Precision optics direct more lighting to the roadway
- No uplight (U0 rating) for Dark Sky friendly lighting
- Field upgradable connected lighting solutions



Note: The luminaires and optical distributions shown are examples. Confirm which RoadFocus is right for you using a photometric layout of your application.



At night, RoadFocus LED Luminaires come alive, blanketing your roadways with uniform, high-quality, white illumination, while avoiding the shadows and streaks that traditional roadway lighting can produce.

The illumination is purposefully distributed to reduce light pollution and provide an increased sense of security, while our stand-alone and connected outdoor LED lighting solutions help to enhance your sustainability goals through dimming, programmed and wireless management options. Connected lighting solutions may be incorporated now, and can also be easily upgraded in the future as your requirements for controlling the lighting system evolve.

RoadFocus power

Surge protection

Standard SP1 and optional SP2 surge suppressors protect the luminaire

Bird guard

Standard with all RoadFocus luminaires

Mounting

1.66"–2.375" O.D. (1.25"–2" NPS) tenon for optimal mounting versatility –5° to +5° tilt in 2.5° steps

Drivers

The dimming driver (0–10V) is standard and DALI and Sensor Ready drivers are optional, enabling RoadFocus to be combined with additional controls, now or in the future

Die-cast housing

Rugged, die-cast aluminum housing for maximum durability

Sensor Ready Option

Optional SR Driver and Optional Sensor Receptacle add flexibility for now or in the future. The luminaire ship with a protective cap.





Twist-lock receptacles

The standard 7-pin and optional 5-pin NEMA twist lock receptacles facilitate connected lighting solutions that can quickly and easily be upgraded in the future



IP66 Light engines

Reliable light engines are IP66 sealed to protect against dust and moisture so that LED life is extended

Service tag

Includes Service Tag, an innovative way to provide assistance throughout the life of the product.



Field Adjustable Wattage Selector

Optional Field Adjustable Wattage Selector (FAWS) switch can be operated even while wearing Lineman's gloves, providing tactile, audible and visual switch position markers



Shielding

A large selection of shielding options provide further light trespass control and ensure light is only directed where it is needed





"What is off road?"

Going beyond the road

Not all roadway applications are created equal. Poles that are mounted farther away from a roadway, multi-lane highways, toll plazas, and additional applications require special needs. The RoadFocus product family provides a solution to these unique applications.

Stop wasting time looking for a different luminaire for each application. The RoadFocus off road configurations offer a versatile solution for applications that are outside the range of traditional roadway lighting. The specialty designed off road optics maximize the light to the roadway with superior illumination providing excellent uniformity while enhancing the sense of security. From traditional streets to off road applications, the RoadFocus product family will help you simplify your luminaire selection.

- Specialized off road optics direct more light to the roadway
- Versatile adaptor that can be mounted vertically or horizontally
- Available with RoadFocus medium and large offering even more design flexibility
- Variable tilt between -5° and $+45^{\circ}$ (5° steps) offers solutions for a multitude of lighting applications



Adding poles to the center lanes of highways can be costly and difficult to maintain. Lumec has designed the knuckle adaptor to be used specifically in off roadway applications. Combined with specialized optics to be used in a tilt application, the knuckle adaptor can tackle even the most difficult installation. Reduce your number of luminaires and provide quality of light. See the examples below.

Traditional

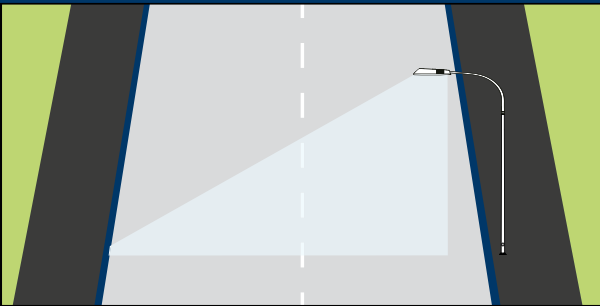

A single luminaire must be placed close to the roadway.

High Tilt



A single high tilt luminaire provides better coverage from a distance.

Wide Road - Traditional



Two luminaires are used for a wide road application.

Wide Road - High Tilt



Single luminaires provide comparable uniformity and light levels

RoadFocus off road

KAH3

Horizontal arm applications shown on RoadFocus medium (RFM)

Off road optics

Specialized off road optics direct more light to the roadway

Angle indicator

Precise angle is indicated by gravity needle.

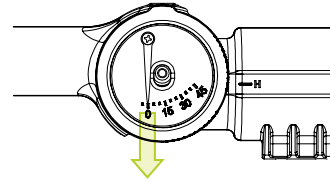

Ratchet-style adjustment

Ratchet-style adjustment allows verification of aiming prior to tightening and final setup

Wire passage

See through wire passage ensures fast and easy installation

Mounting

Horizontal arm applications. Fits from 2 3/8" (60mm) to 3" (76mm) outside diameter mounting arms and tenons

Tilt angle range

Variable tilt between lighting applications -5° and +45° (5° steps)

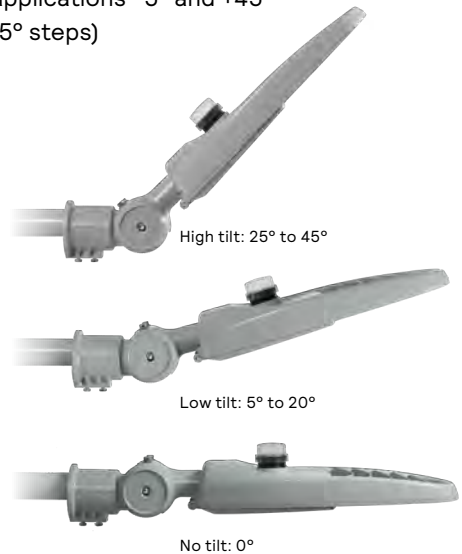

KAV3

Vertical post top applications shown on RoadFocus large (RFL)

Off road optics

Specialized off road optics direct more light to the roadway

Angle indicator

Precise angle is indicated by gravity needle

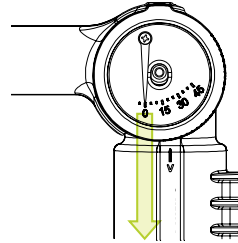

Ratchet-style adjustment

Ratchet-style adjustment allows verification of aiming prior to tightening and final setup

Wire passage

See through wire passage ensures fast and easy installation

Mounting

Vertical post top tenon applications. Fits from 2 3/8" (60mm) to 3" (76mm) outside diameter mounting arms and tenons

Tilt angle range

Variable tilt between lighting applications -5° and +45° (5° steps)





"Where do we start?"

Change starts now

The time is right to reliably upgrade your roadway lighting with RoadFocus LED Luminaires. Not only will you gain powerful and sustainable LED technology with enhanced, energy-saving connected lighting solutions in a familiar cobra head design, you can rest assured knowing that RoadFocus LED Luminaires are backed by our standard 10-year limited warranty.

And by partnering with Lumec, we can provide assistance throughout each step of your transition, from inspiration to installation. Available service options include:

- Project assessment
- Specification writing
- Design solutions
- Customer care and maintenance
- Project oversight and turn-key solutions
- Customized and competitive financing
- Standard 10-year limited warranty
- And much more

Technical information

Dimensions

RoadFocus small (RFS)

Side View

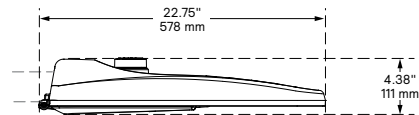

Bottom View

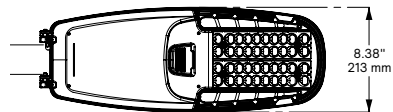

Weight: 9.4 lbs
EPA: 0.52 sq. ft.

RoadFocus medium (RFM)

Side View

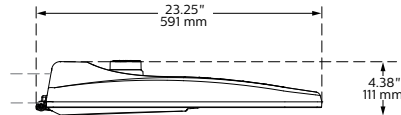

Bottom View

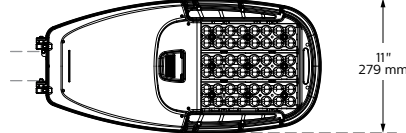

Weight: 12.2 lbs
EPA: 0.53 sq. ft.

RoadFocus large (RFL)

Side View

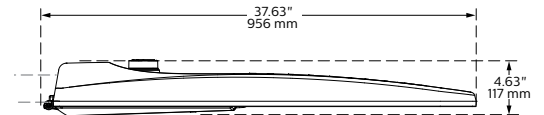

Bottom View

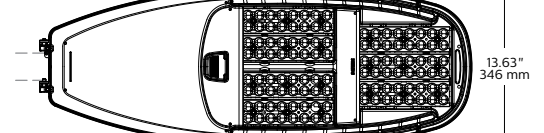

Weight: 27.3 lbs
EPA: 0.92 sq. ft.

Off road adaptors

KAV3

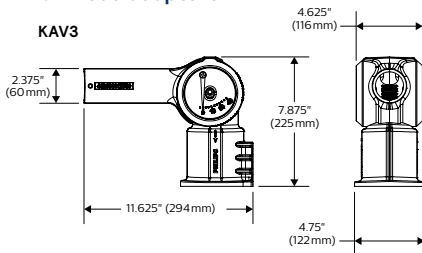

KAH3

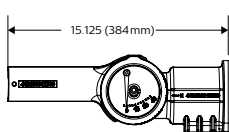

RoadFocus off road medium (RFM)

Side View: Off road configuration (shown on KAH3)

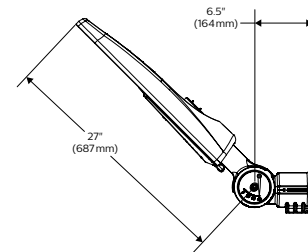

RoadFocus off road large (RFL)

Side View: Off road configuration (shown on KAH3)

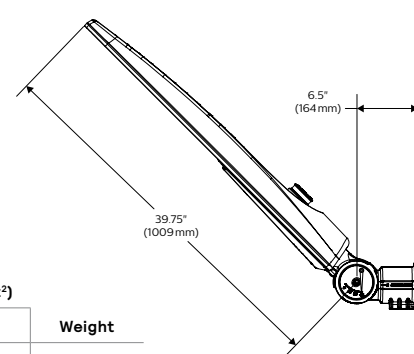

Effective Projected Area (EPA-ft²)

	0° Aim	45° Aim	Weight
RFL + Adaptor	1.24	3.16	33.6 lb
RFM + Adaptor	0.85	1.81	18.5 lb

Luminaire Options

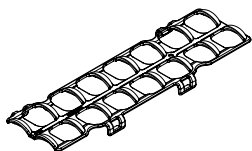

CSS

Cul-de-Sac Shield

LSS

Left Side Shield

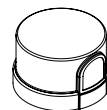

PH8

Photocell

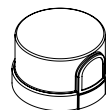

PHXL

Photocell, Extended Life

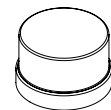

PH9

Shorting Cap

FSS

Front Side Shield

RSS

Right Side Shield

HS

House Side Shield

Luminaire Accessories

Please note that accessories need to be ordered as separate line items, and they are quickly and easily installed in the field. See ordering guide on specification sheets for exact catalog logic.

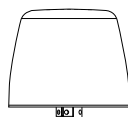

Interact City connector node



Sensor Ready Options

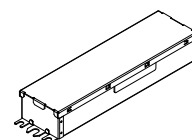

SRD

Sensor ready driver, available in multiple configurations



TLRSR

Sensor receptacle

Prior to ordering, consult specification sheets on signify.com/prolighting for the most current information, notes, and exclusions.

Controls



Luminaire solutions

Basic. Autonomous. Affordable.

Simple, individual outdoor lighting dimming and management without the need for remote access.

- Field Adjustable Wattage Selector



City solutions

Advanced. Powerful. Extensive.

Widespread or multi-site lighting management with detailed asset management that can grow along with your needs.

- Interact City Connected Lighting System with Interact City connector node

Do you want more?

You can enhance your connected lighting systems with the options below.

- Sensor Ready Driver
- Sensor Ready Receptacle

For more information

Visit us at [signify.com/prolighting](https://www.signify.com/prolighting) for more on Signify stand-alone and connected outdoor lighting solutions, and select Controls Outdoor, or request our outdoor lighting solutions brochure.

Service tag



Making LED maintenance operations easier and faster

RoadFocus LED Cobra Head luminaires come standard with Signify Service tag, a unique QR based identification system placed on products, poles and boxes they are delivered in. After installing the luminaire, simply read the tag from the app to register the product. By registering the product, you are sure Signify will provide support throughout the lifetime of the product.

- Provides easy access to lighting component information at the right time and place.
- Enables more effective maintenance operations by identifying spare parts

www.philips.com/servicetag



Take the next step

See how Lumec RoadFocus LED Cobra head luminaires can provide a complete solution for your roadway lighting needs. Contact your local Signify Sales Representative or visit [signify.com/roadfocus](https://www.signify.com/roadfocus) for more information or to schedule a personalized demonstration.

